

YATAY DİKEY DÖNER TABLA



HV-6, 8, 10, 12, 14, 16

 ÖZEL AKSESUARLAR
(DETAYLAR 130. SAYFADADIR)

HV-4



New Model

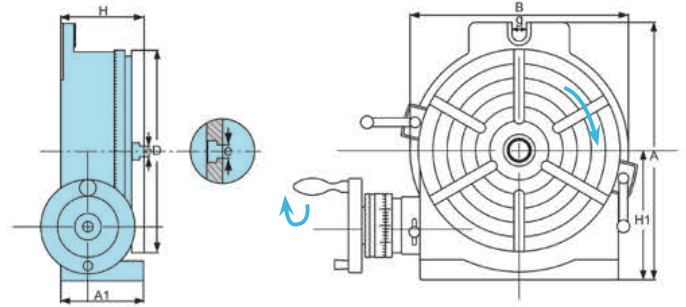

KOD	TABLA			TABAN ÖLÇÜSÜ			T-KANAL UZUNLUĞU		BAĞLANTI YUVASI	DÖNER TABLA İÇİN YÜK KAPASİTESİ		MERKEZ KONİĞİ	BRÜT AĞIRLIK TAHTA KUTU (T) KARTON (K)	FİYAT USD	
	DIŞ ÇAP		YÜKSEKLİK	H1	A	B	e	TİP		g	YATAY				DİKEY
	A1	D	H												
HV-4	58	110	72	80	138	118	11	⊕	17	35 Kg	18 Kg	MK2	(K)	7.5 Kg	
HV-6	78	150	80	102	205	163	11	⊕	17	40 Kg	20 Kg	MK2	(K)	12.7 Kg	
HV-8	100	205	102	135	265	219	14	⊕	17	80 Kg	40 Kg	MK3	(K)	26.2 Kg	
HV-10	106	254	109	163	321	276	14	⊗	17	90 Kg	50 Kg	MK3	(K)	37.3 Kg	
HV-12	123	305	125	194	388	330	16	⊗	18	120 Kg	60 Kg	MK4	(T)	69.8 Kg	
HV-14	123	353	125	225	445	389	16	⊗	18	130 Kg	70 Kg	MK4	(T)	90.3 Kg	
HV-16	128	406	130	258	503	435	16	⊗	18	140 Kg	70 Kg	MK4	(T)	123.1 Kg	

NO.	TEST KONUSU	SAPMA 100mm (inch) (mm)
1	KAPANMA YÜZEYİ DÜZLEMSELLİĞİ (KONKAV)	.0006" (0.015mm)
2	KAPANMA YÜZEYİNİN TABANA GÖRE PARELELLİĞİ	.0008" (0.02mm)
3	KAPANMA YÜZEYİNİN AÇI YÜZÜNE GÖRE KARESİLLİĞİ	.0008" (0.02mm)
4	KAPANMA YÜZEYİNİN GERÇEK SALGISI	.0006" (0.015mm)
5	MERKEZ DELİĞİNİN DELİK SINIRINDAKİ GERÇEK SALGISI	.0008" (0.02mm)

- YÜKSEK YOĞUNLUKLU MEHENİT' TEN ÜRETİLMİŞTİR ve MÜKEMMEL KALİTE ve DEVAMLILIK İÇİN "HEIDENHAIN" ELEKTRONİK CİHAZLARLA TEST EDİLMİŞTİR.
- MİL HASSAS BİÇİMDE YATAKLANMIŞTIR. BU DA AĞIR YÜKLERDE SAĞLAMLIK SAĞLAR.
- SALLYANGOZ DIŞLI SERTLEŞTİRİLMİŞ ve TAŞLANMIŞTIR.
- DIŞLI ORANI 90:1'DİR.
- ÇALIŞMA TABLASI TAM 360° DERECELENDİRİLMİŞTİR. KOLUN HER BİR TURU TABLAYI 4° HAREKET ETTİRİR. MİKRO AYAR 1'ER DAKİKA OLARAK DERECELENDİRİLMİŞTİR. VERNİERLİ SKALA 10 SANİYEE KADAR AYAR İMKANI SAĞLAR.
- BU DÖNER TABLALAR MÜKEMMEL PERFORMANSLARI, PRATİK DİZAYNLARI ve UYGUN FİYATLARINDAN DOLAYI ÇOK TERCİH EDİLİR. KULLANIM ALANLARI DAİRESEL İŞLEME, AÇISAL İŞLEME, BARALAMA VS GİBİ OLDUKÇA GENİŞTİR.

DÖNER TABLA ÖZEL AKSESUARLAR
DİVİZÖR PLAKALAR

DP-2, 3, 4, 5



DP-1



KOD	UYGUN OLDUĞU MODEL	AĞIRLIK (Kg)	FİYAT USD
*DP-1	HV-4, HV-6, VUT-6, VU-100, 150	1.4	

A-PLAKA	15, 16, 17, 18, 19, 20
B-PLAKA	21, 23, 27, 29, 31, 33
C-PLAKA	37, 39, 41, 43, 47, 49

 1 SET İÇEREN
1 KARTON

 DP SET, İNDEKS PLAKA, KRANK KOLU,
3 ADET VİDA, SEKTÖR ve U-PUL İÇERİR
BRÜT AĞIRLIK:3,5 Kg

DİVİZÖR PLAKALARIN DELİK SAYILARI

KOD	UYGUN OLDUĞU MODEL	AĞIRLIK (Kg)	FİYAT USD
*DP-2	HV-8, VU-200	4.5	
DP-3	HV-10,12,14,16, VUT-10, 12	4.6	
DP-4	CS-6, 8	4.6	
DP-5	VU-300	4.6	

A-PLAKA	26, 30, 34, 38, 41, 44, 47, 51, 57, 28, 32, 37, 39, 43, 46, 49, 53, 59
B-PLAKA	61, 67, 71, 77, 81, 87, 91, 97, 63, 69, 73, 79, 83, 89, 93, 99

KARŞI PUNTA



TS2-TS3-TS4



TS-1

KOD	AYAR ARALIĞI		UYGUN OLDUĞU MODEL	AĞIRLIK (Kg)	FİYAT USD
	EN YÜKSEK	EN DÜŞÜK			
TS-1	108	80	HV-4, HV-6, VSI-4, VSI-5, BS-0, VUT-6, VU-100, VU-150	3.9	
TS-2	145	115	BS-1, CC-6, CS-6, HV-8	5.5	
TS-3	200	130	CS-8, HV-10, HV-12, CC-8, VUT-10, VUT-12, VU-200	8.1	
TS-4	260	182	HV-14, HV-16	11.9	

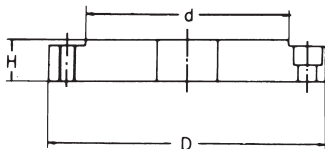
FLANŞ

 VSC-5F için FLT-0
 VSC-6F için FLT-1
 VSC-7F için FLT-2
 VSC-8F için FLT-3

DETAYLAR

KOD	D	d	H	UYGUN OLDUĞU MODEL	AĞIRLIK (Kg)	FİYAT USD
FLT-0	138	100	20	HV-6, 8, VU-150, 200	1.9	
FLT-1	170	130	21	HV-8, 10, VU-200	3.3	
FLT-2	195	155	24	HV-10, 12, 14	5.2	
FLT-3	210	160	24	HV-10, 12, 14, 16	4.9	

NC DÖNER TABLA KARŞI PUNTASI

Sabit Punta



Döner Punta (MK3)

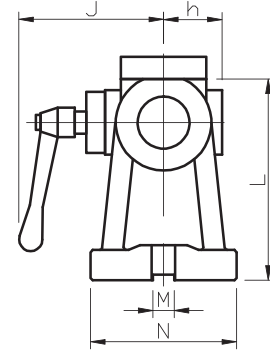
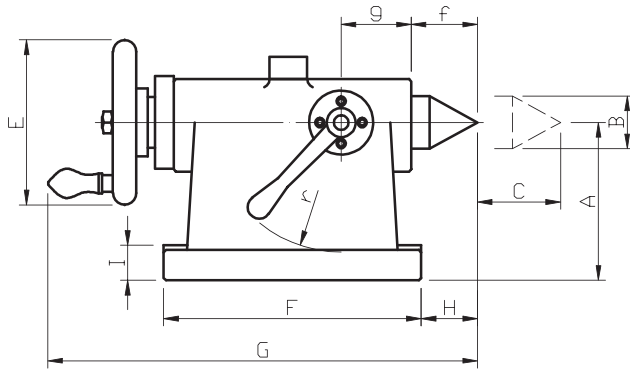

ANA ÖLÇÜLER		MERKEZ YÜKSEKLİĞİ	MERKEZ ÇAPI	KURS BOYU	PUNTA UÇ ÇAPI	ÇARK ÇAPI	TABAN ÖLÇÜLERİ FxM	G	H	I	J	K	L	FİYAT USD
KOD	UYGUN MODEL	A	B	C	D	E								
TS-135	VNCM-150	135	Ø45 MK#3	55	Ø14	125	215x120	332	25	25	109	-	164	
TS-135-MK3		135												
TS-160	VNCM-220 VNCX-10 VNCM-250	160			Ø18	140	230x130	356	30	30	129	53	193	
TS-160-MK3							230x146							243
TS-210	VNCM-320	210												243

ANA ÖLÇÜLER		M	c	u	f	g	h	j	r	AĞIRLIK (Kg)
KOD	UYGUN MODEL									
TS-135	VNCM-150	18	42	19	40	69	44	70	80	20,6
			46							
TS-135-MK3			46							
TS-160	VNCM-220 VNCX-10 VNCM-250	18	49	19	45	70	52	80	95	23,1
TS-160-MK3			51							
TS-210	VNCM-320	18	51	23	45	70	52	80	95	29,4
TS-210-MK3			57							

YUKARIDAKİ TABLODA LİSTELENEN MODELLER UYGULANABİLİR METALLERİN ÖRNEKLERİDİR. DÖNDÜRÜLEBİLİR TABLANIN MERKEZ YÜKSEKLİĞİ ve BÖLME BAŞLIKLARI GEZER PUNTANIN YÜKSEKLİKLERİYLE AYNI OLMALIDIR.

ÜNİVERSAL AÇILI DÖNER TABLA

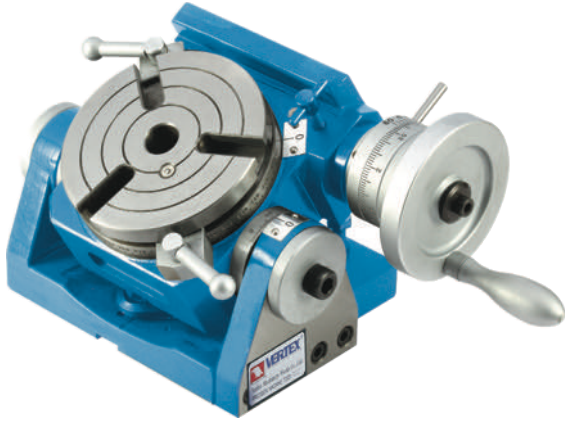

- HAREKET ARALIĞI 0-90° DİR. RİJİTLİĞİ YÜKSEKTİR.
- MİNİMUM KURULUM SÜRESİ: SABİTLEMELİK İÇİN İKİ VİDA VARDIR. YÜKSEK KAPASİTE İÇİN GÖVDE PROFİLİ DÜŞÜK TUTULMUŞTUR.
- SALYANGOZ DİŞLİ SERTLEŞTİRİLMİŞ ve TAŞLANMIŞTIR.
- DİŞLİ ORANI 90:1'DİR.
- ÇALIŞMA TABLASI TAM 360° DERECELENDİRİLMİŞTİR. KOLUN HER BİR TURU TABLAYI 4° HAREKET ETTİRİR. MİKRO AYAR 1'ER DAKİKA OLARAK DERECELENDİRİLMİŞTİR. VERNİERLİ SKALA 10 SANİYEYE KADAR AYAR İMKANI SAĞLAR.
- KARŞI PUNTA ve DİVİZÖR PLEYTLERİ OPSİYONELDİR. ÖLÇÜLER DÖNER TABLA İLE AYNIYDUR.
- **LÜTFEN 130. NOLU SAYFAYA BAKINIZ.**
- TAŞLAMA, MATKAP ve ARK YA DA İNDEKS KESİCİ FREZE MAKİNALARINA UYGUNDUR.

OPSİYONEL



1.KARŞI PUNTA

KOD	FİYAT USD
TS-1	
TS-3	

2.DİVİZÖR PLEYT

KOD	FİYAT USD
* VU-100, 150 İÇİN DP-1	
* VU-200 İÇİN DP-2	

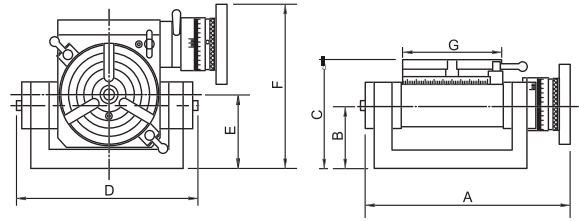

DETAYLAR

KOD	A	B	C	D	E	F	G	UYGUN KARŞI PUNTA	UYGUN DİVİZÖR PLEYT	AĞIRLIK (Kg)	FİYAT USD
VU-100	228	68	117	202	80	177	110	TS-1	DP-1	13,5	
VU-150	266	75	140	246	90	216	150	TS-1	DP-1	21,5	
VU-200	429	111	177	432	141	283	205	TS-3	DP-2	46,0	

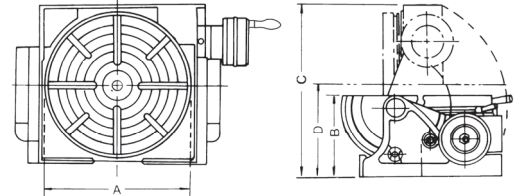
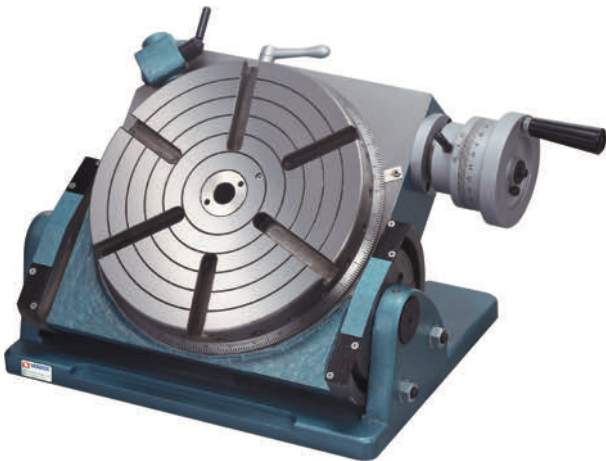

KOD	VU-300
TABLA ÇAPI (A)	300 mm
TABLA YÜKSEKLİĞİ (YATAY) (B)	185 mm
TABLA YÜKSEKLİĞİ (DİKEY) (C)	370 mm
MERKEZ DELİK	MK3
DELİK YÜKSEKLİĞİ (DİKEY) (D)	208 mm
DİREKT İNDEKSLEME	24-div
DİŞLİ ORANI	90:1
BRÜT AĞIRLIK	102 Kgs
NET AĞIRLIK	99,5 Kgs
FİYAT USD	

- BU TABLA FREZELEME, BARALAMA ve DİĞER MAKİNALAR İÇİN ÖZEL OLARAK DİZAYN EDİLMİŞTİR.
- BU TABLA İNDEKSLEME, ALIN TORNALAMA ve DİĞER İŞLEMLERİN HIZLI ve YÜKSEK HASSASİYET İLE YAPILMASINI SAĞLAR.
- HAREKET ARALIĞI 0-90°DİR. KOLUN BİR DÖNÜŞÜ 3 DERECE ve 5 DAKİKAYA EŞİTTİR.
- TABLA ÖLÇEĞİ 1 DAKİKA OLARAK ÖLÇEKLENDİRİLMİŞTİR.
- KURULUM SÜRESİ MİNİMUMDUR.
- SAĞLAM BİR GÖVDEYE SAHİPTİR.

ÖZEL AKSESUARLAR

- DİVİZÖR PLEYTİ
- KARŞI PUNTA



ÜNİVERSAL AÇILI TABLA



- AÇILI TABLA HASSAS TAŞLANMIŞ RİJİT TASARIM
- YATAY 360°, DİKEY 45° HAREKET KABİLİYETİ
- VMV ve VDV TİP MENGENE İLE 3 AYAKLI AYNA TAKILABİLİR.
- HASSAS OKUMA İÇİN ÖLÇÜLENDİRİLMİŞTİR.
- PARALELLİK $\pm 0,02$ mm
- KARESELLİK $\pm 0,02$ mm
- MALZEME SK-2
- SERTLİK HRC 52° ± 2 °

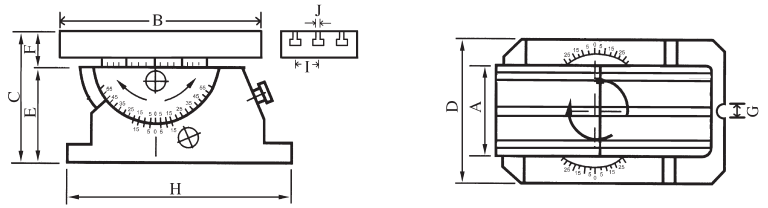

DETAYLAR

KOD	A	B	C	D	E	F	G	H	I	J	AĞIRLIK (Kg)	FİYAT USD
VUA-408	100	200	133	110	83	50	16	182	30	12	15	
VUA-510	126	250	133	110	83	50	16	182	40	12	18.1	

HASSAS ÜNİVERSAL AÇILI MENGENE



VUA-4

- DOĞRU BİR OKUMA İÇİN HASSAS ÖLÇEKLİNDİRİLMİŞTİR.
- YATAY ve DİKEY HAREKET KABİLİYETİ MENGENEYİ EĞİMLİ ve ZOR PARÇALAR İÇİN İDEAL KILAR.
- HASSAS TAŞLAMA, FREZELEME ve BARALAMA MAKİNALARINDA KULLANILABİLİR.

TOLERANS : $\pm 0,01$ mm/100 mm
 MENGENE TABAN PARALELLİĞİ : $\pm 0,02$ mm
 KARESELLİK : $\pm 0,02$ mm
 360° YATAY HAREKET
 45° DİKEY HAREKET
 HASSAS TAŞLAMA
 SK-2 MALZEME
 SERTLİK: HRC 52° ± 2 °

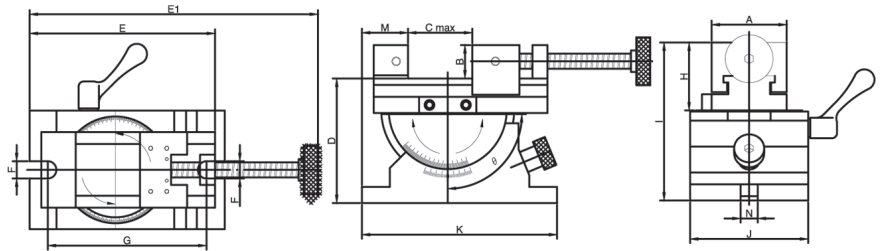

DETAYLAR

KOD	A	B	C AÇILIM	D	E	E1	F	G	H	I	J	K	M	N	θ	AĞIRLIK (Kg)	FİYAT USD
VUA-3	70	31	80	115	173	291	16	156	63	146	110	182	43	16	-20°~50°	12	
VUA-4	88	35	100	132	193	346	16	156	83	167	110	182	29	16	-20°~50°	15	

360° 2 AÇILI TABLA

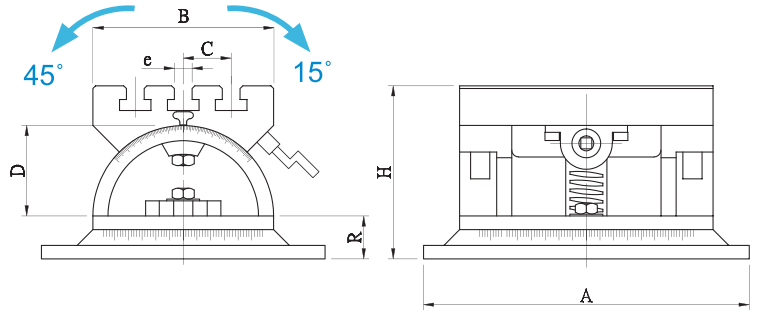
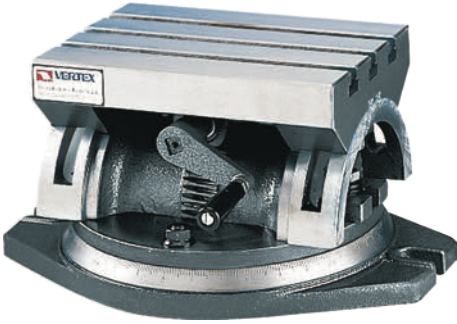

- ÇEŞİTLİ TEZGAHLARDA AÇI SABİTLEMELİK İÇİN KULLANILIR.
- MALZEMESİ FC25'DİR.
- DAHA ALÇAK AÇILI TABLA İLE DAHA BÜYÜK ÇALIŞMA ALANI SAĞLAR.

DETAYLAR

KOD	TABLA			T-YUVA			R	AĞIRLIK (Kg)	FİYAT USD
	A	B	H	e	C	D			
VP-250S	290	180	206	16	50	105	52	36	
VP-380S	390	360	255	16	68	127	60	86	

EKONOMİK TİP YATAY DİKEY İNDEKS DİVİZÖR

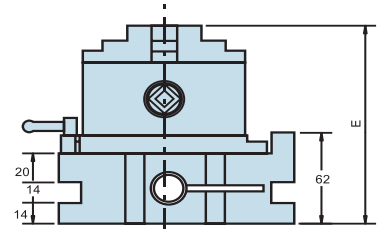
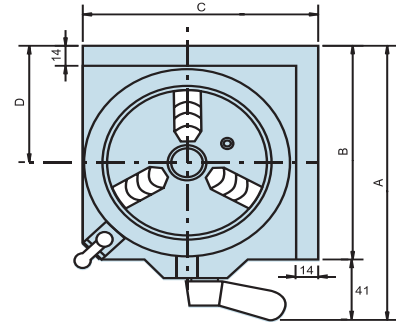
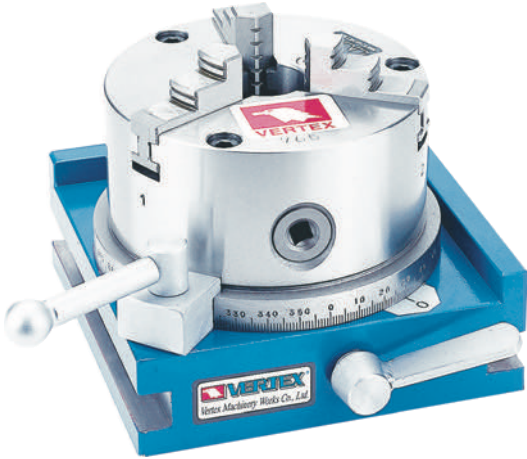

- BÜYÜK KAPASİTESİ (Ø3-Ø100) İLE PENS SİSTEMİNDEN DAHA İYİDİR.
- BASİT ve HIZLI OPERASYON 15°LİK 24 DELİKLİ PLAKA
- AÇISAL İNDEKSELEME İÇİN TABLA ÖLÇEĞİ 1°DİR.
- TABLA DELİĞİ 30 mm'DİR.
- YATAY-DİKEY KULLANIM
- FREZELEME ve MATKAP MAKİNALARINA UYGUNDUR.
- OPSİYONEL OLARAK 130. SAYFADAKİ TS-1 KARŞI PUNTA KULLANILABİLİR.

DETAYLAR

KOD	A	B	C	D	E	DELİK ÇAPI	AĞIRLIK (Kg)	FİYAT USD
VSI-4	187	146	146	80	135	Ø 30	10.5	
VSI-5	202	161	161	87	142	Ø 30	14,5	

YATAY DİKEY İNDEKS DİVİZÖR

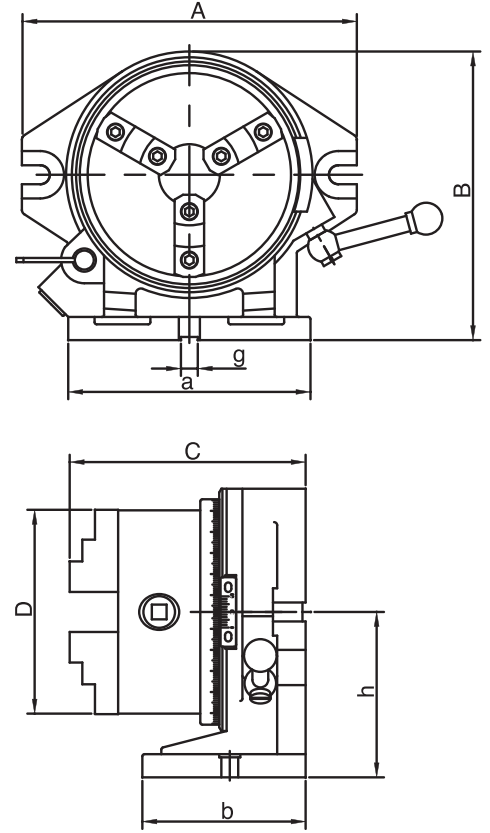

BÜYÜK MERKEZ DİZAYNI

- MERKEZ DELİK BÜYÜK ve UZUN PARÇALARA UYGUN ŞEKİLDE BÜYÜK TUTULMUŞTUR.
- SERTLEŞTİRİLMİŞ ve TAŞLANMIŞ 24 POZİSYONLU PLAKA ÖZEL BİR AÇI OLAN 15°'Yİ MÜKEMMEL BİR HASSASİYETLE SAĞLAR.
- CS TİP DÖNDÜRÜLEBİLİR 3 AYAKLI AYNA İLE KULLANILABİLİR. AYRICA, YÜZEY PLAKASI İLE EŞLENDİĞİNDE DÖNER TABLA İŞLEVİ GÖREBİLİR.
- HIZLI İNDEKSLENİR ve KOLAY KULLANILIR. SERİ ÜRETİM İÇİN VAZGEÇİLMEZ BİR ÜRÜNDÜR.
- YATAY - DİKEY İNDEKS DİVİZÖR PAKET İÇERİĞİNDE 3 AYAKLI AYNA, MASKELEME PLAKALARI 2,3,4,6,8,12 MEVCUTTUR.

**ÖZEL AKSESUARLAR
DÖNER TABLA İLE AYNIYDIR.
DETAYLAR İÇİN 130. SAYFAYA BAKINIZ.**



İNDEKS DİVİZÖRLER İÇİN HASSASİYET STANDARTLARI

NO.	TEST KONUSU	SAPMA 100mm (inch)
1	12" E GÖRE TABLA YÜZEYİ İLE TABANIN PARALELLİĞİ	0,015
2	TABLA YÜZEYİNİN EKSENEL HAREKET GERÇEK SALGISI	
3	MERKEZ ÜNİTENİN GERÇEK SALGISI	0,010
4	12" E GÖRE AÇI YÜZEYİ İLE TABANIN KARESELLİĞİ	0,020
5	AYNA MERKEZİNİN GERÇEK SALGISI	0,030

DETAYLAR

KOD	DİVİZÖR NO.	A	B	C	D	a	b	h	TERS AYAK	KILAVUZ DELİĞİ	DÜZ AYAK	DELİK ÇAPI (TARET)	DELİK ÇAPI (AYNA)	AĞIRLIK (Kg)	FİYAT USD
										g					
CC-6	2,3,4,6 8,12,24	253	225	179	160	187	115	130	Ø55~145	16	Ø3~160	44	44	(K) 29.5	
CC-8	2,3,4,6 8,12,24	318	274	209	200	230	155	157	Ø65~200	16	Ø4~200	63	58	(K) 51.5	

YATAY DİKEY SÜPER İNDEKS DİVİZÖR



STANDART AKSESUARLAR



ÖZEL AKSESUARLAR DÖNER TABLA İLE AYNIYDIR. DETAYLAR İÇİN 130. SAYFAYA BAKINIZ.



CS8, 3 AYAKLI AYNA İLE BİRLİKTE MASKELEME PLAKASI & YÜZEY PLAKASI

BU ÜRÜN SÜPER İNDEKS İLE SALLYANGOZ DİŞLİ İNDEKSİN AVANTAJLARINI BİRLEŞTİRİR. FREZE, BARA YA DA BAŞKA BİR MAKİNAYA TAKILDIĞINDA SALLYANGOZ TAHRİK MEKANİZMASI SAYESİNDE TEKİL İNDEKS ve ENDİREKT İNDEKS İŞLEMLERİNİ GERÇEKLEŞTİREBİLİR. SALLYANGOZ TAHRİĞİ DEVRE DIŞI BIRAKILARAK 24 DELİKLİ ANA PLAKANIN 2,3,4,6,8,12 ve 24' E BÖLME İŞLEMİ YAPMASI SAĞLANABİLİR. AYNA ÇIKARILDIĞINDA YATAY-DİKEY TİP DÖNER TABLA OLARAK KULLANILABİLİR. DİŞLİ ORANI 1:90'DIR. OPERASYON KOLU 1 DAKİKA OLARAK DERECELENDİRİLMİŞTİR. 10 SANİYE HASSASİYETİNE KADAR OKUMA YAPILABİLİR.

• SÜPER İNDEKS DİVİZÖRLER, 3 AYAKLI AYNA, 10"/250 mm YÜZEY PLAKASI, MASKELEME PLAKALARI 2,3,4,6,8,12 İLE BİRLİKTE GELİR.

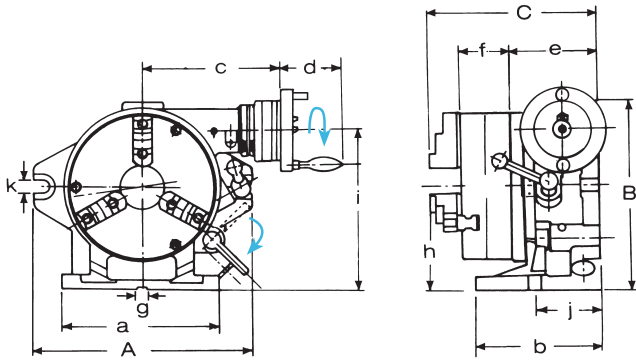

CS-8'İN GÖVDESİ,
YÜZEY PLAKASI VE
DİVİZÖR PLAKASI
İLE UYUMLUDUR.

DETAYLAR

KOD	DİVİZÖR SAYISI	AYNA				YÜZEY PLAKASI		A	B	C	a	FİYAT USD
		DIŞ ÇAP	İÇ AYAK	DIŞ AYAK	İÇ ÇAP	DIŞ ÇAP	KALINLIK					
CS-6	2,3,4,6 8,12,24	167 VSK-6	Ø4-42	Ø10-156	44	203	50	250	235	221	220	
CS-8	2,3,4,6 8,12,24	210 VSK-8	Ø4-62	Ø10-180	63	254	58	310	285	243	225	

KOD	b	c	d	e	f	KILAVUZ DELİĞİ	h	i	j	k	AĞIRLIK (Kg)
						g					
CS-6	150	184	82	112	66	16	123	186	80	18	(K) 44,5
CS-8	160	201	82	125	75	16	155	232	80	18	(T) 71,5

YARI ÜNİVERSAL DİVİZÖR



KOD	AĞIRLIK (Kg)	BAĞLANABİLİR AYNA ÖLÇÜSÜ	FİYAT USD
BS-0	20	Ø 125	
BS-1	33	Ø 160	

DİŞ MİLLERİ

BS-0. 1 1/8 - 12TPI
BS-1. 1 1/2 - 8TPI



STANDART AKSESUARLAR

DİVİZÖR PLAKALARI

PLAKA A	15	16	17	18	19	20
PLAKA B	21	23	27	29	31	33
PLAKA C	37	39	41	43	47	49

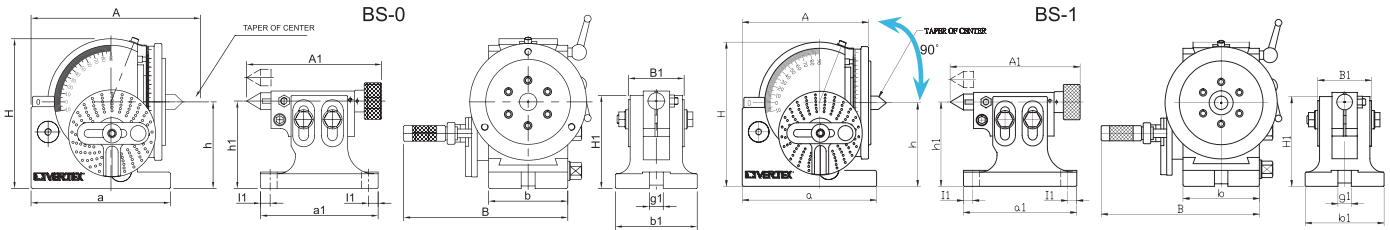

DİVİZÖR

KOD	A	B	H	I	a	b	g	h	MERKEZ KONİĞİ	MİL DELİĞİ ÇAPI
BS-0	177	188	173	13	160	91	16	100	MK-2	18
BS-1	245	230	220	19	205	114	16	128	MK-3	20

KARŞI PUNTA

KOD	A1	B1	H1	I1	a1	h1	b1	g1
BS-0	155-180	64	107	11	134	80-108	94	16
BS-1	170-195	64	150	11	155	150-115	110	16

- DİVİZÖR HERHANGİ BİR AÇIYI DİREKT, ENDİREKT YA DA FARKLI BİR METOD İLE BÖLEBİLİR. DİŞLİ ORANI 1:40'DIR.
- SERTLEŞTİRİLMİŞ ve TAŞLANMIŞ MİL KONİK DÖNER YATAK İÇERİSİNDE RİJİT BİR ŞEKİLDE HAREKET ETMEKTEDİR. AYRICA SALYANGOZ TAŞLANMIŞ VE SERTLEŞTİRİLMİŞTİR.
- DÖNER KAFA YATAY 10° ALTI İLE DİKEY 90° ARASI HER AÇIDA SABİTLENEBİLİR.
- TÜM MODELLER 2,3,4,6,8,12 ve 24'E DOĞRUDAN HIZLI BÖLÜNEBİLMESİNİ SAĞLAYAN 24 DELİKLİ AÇI PLAKALARINA SAHİPTİR.
- 2-50 ARASI TÜM ve 52-380 ARASI BİRCOK SAYIYA KOLAYCA İNDEKLENEBİLİR.

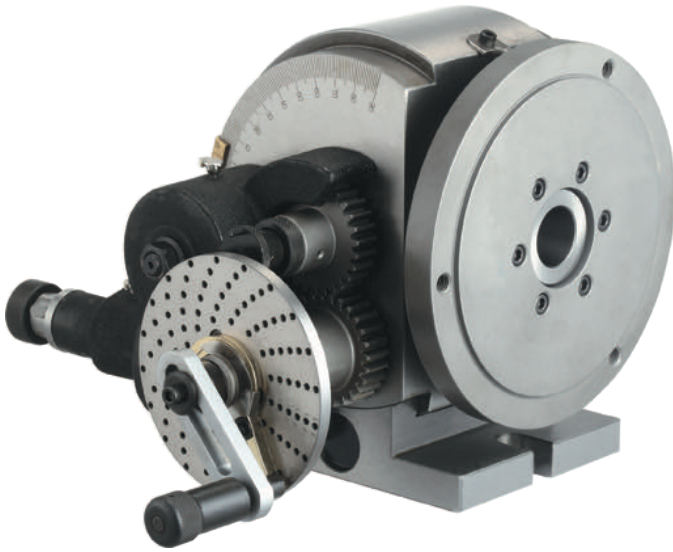
ÜNİVERSAL DİVİZÖR

STANDART AKSESUARLAR

DİŞ MİLLERİ
2 1/4" - 8 TPI

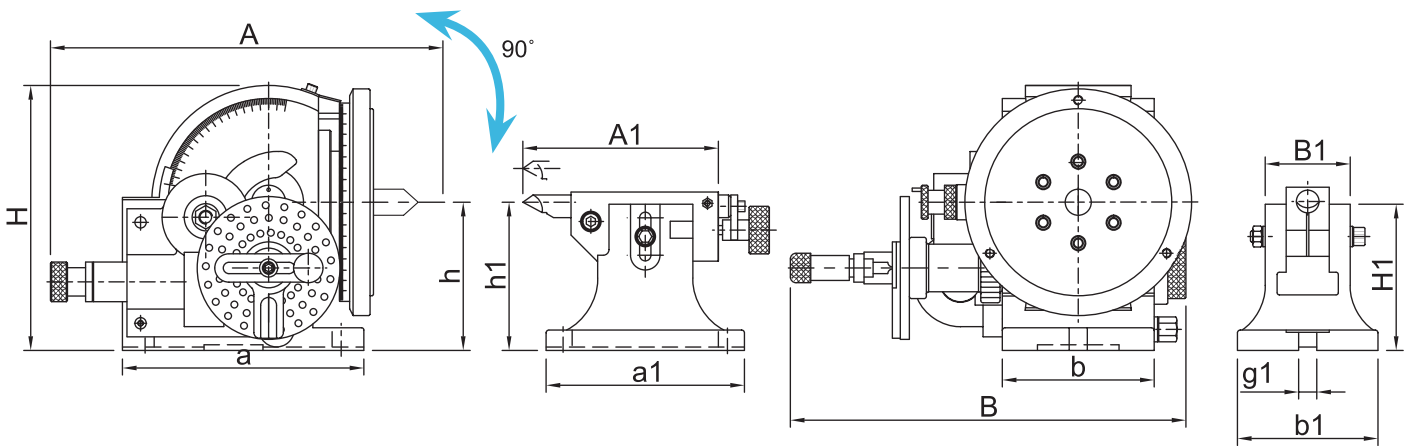
KOD	AĞIRLIK (Kg)	BAĞLANABİLİR AYNA ÖLÇÜSÜ	FİYAT USD
BS-2	65	Ø 160 & Ø 200	

DİVİZÖR

KOD	A	B	H	l	a	b	g	h	MERKEZ KONİĞİ	MİL YUVASI
BS-2	365	272	236	132.7	213	134	16	134	MK-4	25.4

KARŞI PUNTA

KOD	A1	B1	H1	h1	a1	b1	g1
BS-2	205~255	86	139	132.7	175	124	16

HASSAS ÇAPRAZ SUPPORT

VCT-407

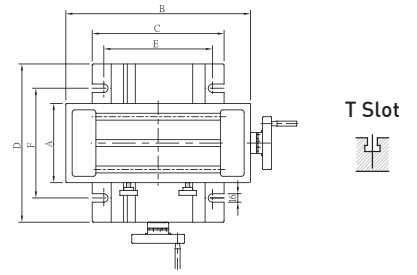
VCT-514

- MALZEME : FC-30 ÜSTÜ
- HASSASİYET : 0,02/100 mm
- HAREKETLİ YÜZEYLER ISIL İŞLEME TABİ TUTULMUŞ ve HASSAS TAŞLANMIŞTIR.
- ÖLÇÜM TABLASI OLARAK KULLANILABİLİR.

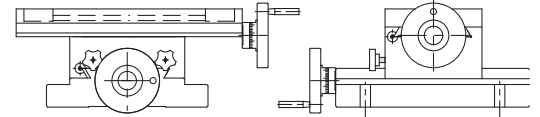
DETAYLAR

KOD	A	B	C	D	E	F	HAREKET	T YUVA	TOPLAM YÜKSEKLİK	ÖLÇEK ORANI	MAX. YÜK (Kg)	AĞIRLIK (Kg)	FİYAT USD
VCT-407	100	180	130	100	115	50	50x80	3/8"	100	2.5 mm/0.02	35	12	
VCT-514	150	350	250	300	206	208	156x170	3/8"	134	4 mm/0.02	105	33.5	
VCT-820	200	500	300	400	250	290	200x250	3/8"	155	4 mm/0.02	140	72	
VCT-1024	250	600	400	500	340	430	250x300	1/2"	210	4 mm/0.02	175	141	

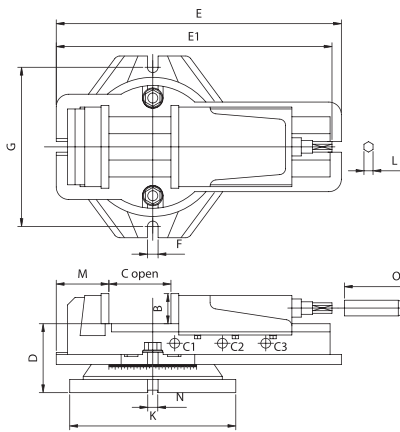
UZUN TİP SÜPER OPEN MENEĞENE

VJ-600
DETAYLAR

KOD	A	B	C AÇILIM	AÇILMA KAPASİTESİ			D	E	E1	F	G
				C1	C2	C3					
VJ-400	110	38	185	0-65	52-129	116-185	97	386	516	15	240
VJ-500	132	48	245	0-78	70-158	150-245	110	455	580	17	255
VJ-600	154	56	305	0-111	97-211	197-305	118	546	722	17	255

DETAYLAR

KOD	H	I	J	K	L	M	N	O	MAX. KAPANMA GÜCÜ (Kg)	AĞIRLIK (Kg)	FİYAT USD
VJ-400	96	135	270	238	14,5	90	16	156	1500	25	
VJ-500	113	158	290	265	14,5	85	16	166	1500	34	
VJ-600	131	175	290	265	19	111	16	200	1500	46	

FREZE MENGENESİ

VA-8L

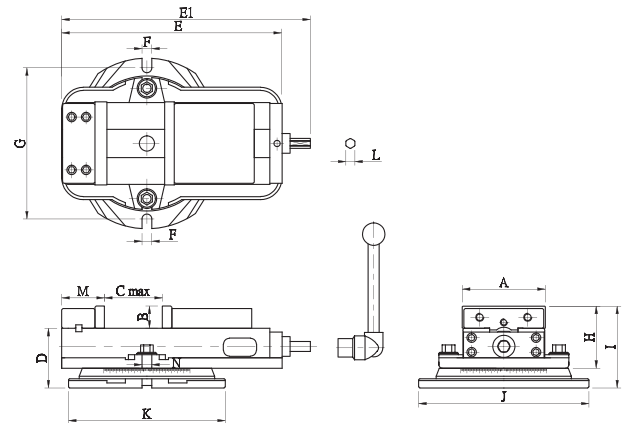
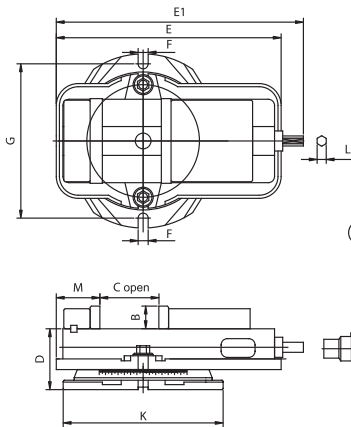
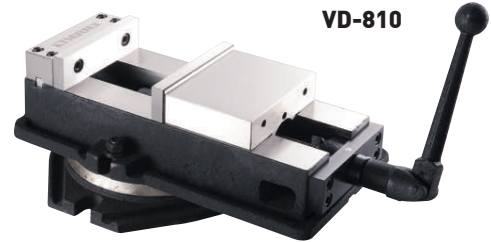
**VD-690
VD-810**

- ÇENELER ve HAREKETLİ YÜZEYLER SERTLEŞTİRİLMİŞ ve TAŞLANMIŞTIR.
- MAKSİMUM KAPANMA GÜCÜ SAĞLAR.
- HASSAS ve SAĞLAMDIR.
- BU MENGENE SIKILAN KOLUN HAREKETLİ ÇENE İÇERSİNDEKİ YARIM DAİREYİ SIKIŞTIRMASI İLE YATAY GÜCÜN HAREKETLİ ÇENEYİ AŞAĞI BASTIRMASINI SAĞLAYACAK ŞEKİLDE DİZAYN EDİLMİŞTİR.
- BU SAYEDE İŞLENEN PARÇA ÇENELERİN ÜST KISMINDA OLSA BİLE YUKARI KALKMAZ.
- 4 ADET YERLEŞİM POZİSYONU DAHA GENİŞ ÇENE AÇILIMI SAĞLAR.
- YENİ MODELLER VD675 İLE VA-8L NİN İKİ ÖNEMLİ FARKI VARDIR. BİRİNCİSİ DAHA GENİŞ AÇILMA KAPASİTELERİ İKİNCİSİ İSE YENİ SABİT ÇENEDEKİ ESNEMENİN BÜYÜK BAĞLANTI ELEMANLARI İLE %50 AZALTIYIMIS OLMASIDIR.
- HASSASİYETİ 0,02 mm'DİR.

DETAYLAR

KOD	A	B	C AÇILIM	D	E	E1	F	G	H	I	J	K	L	M	N	P	MAX. KAPANMA gücü (Kg)	AĞIRLIK (Kg)	FİYAT USD
VA-4	106	36	103	90	324	351	13	211	96	126	242	228	14,5	75	16	15	1500	20	
VA-5	135	36	110	97	359	394	17	246	101	133	277	255	14,5	85	16	15	2000	30	
VA-6	155	46	150	110	422	452	20	288	118	158	326	302	19	95	16	17	2500	42	
VA-8	210	60	197	129	553	583	19	355	145	190	395	366	19	105	16	19	3000	80	
VA-8L	208	64	260	138	510	561	17	310	157	202	375	282	19	71	16	19	3000	73	
VD-675	160	49	190	110	445	478	19	296	121	160	333	305	19	80	16	17	2500	42	
VD-690	155	46	230	110	450	480	20	288	118	158	326	302	19	67	16	17	2300	43	
VD-810	205	62	275	129	555	615	19	378	147	191	420	377	19	79	16	17	3000	76	

ŞEKİLLENDİRME VE FREZE MENGENESİ

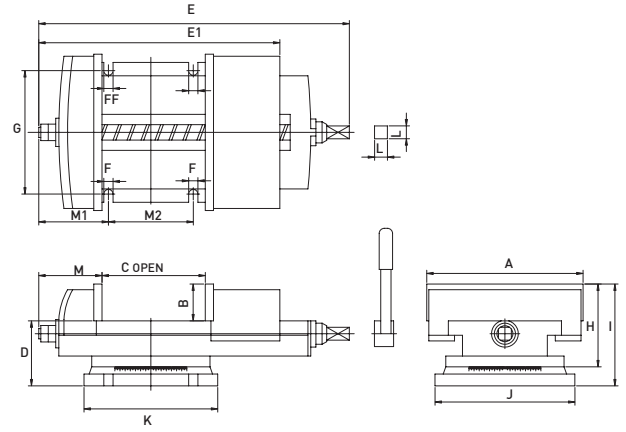

- YÜKSEK GERİLİMLİ DÖKME DEMİRDEN İMAL EDİLMİŞTİR.
- GENİŞ AÇILABİLİR ÇENELERİ ve YÜKSEK KAVRAMA GÜCÜ İLE AĞIR İŞ KESME ve AĞIR İŞ FREZELEME OPERASYONLARINDA BÜYÜK PARÇALARI TUTMAK İÇİN UYGUNDUR.

DETAYLAR

KOD	A	B	C AÇILIM	D	E	E1	F	G	H	I	J	K	L	M	M1	M2	MAX.KAPANMA gücü (Kg)	AĞIRLIK (Kg)	FİYAT USD
VSM-12	304	72	290	126	604	560	18	240	161	198	272	260	25	123	135	165	800	84	
VSM-16	405	96	415	145	763	738	20	292	200	241	336	336	25	135	143	248	1000	142	
VSM-20	508	95	505	150	902	871	21	288	204	245	336	336	25	169	211	246	1200	200	

K TİPİ FREZE MENGENESİ

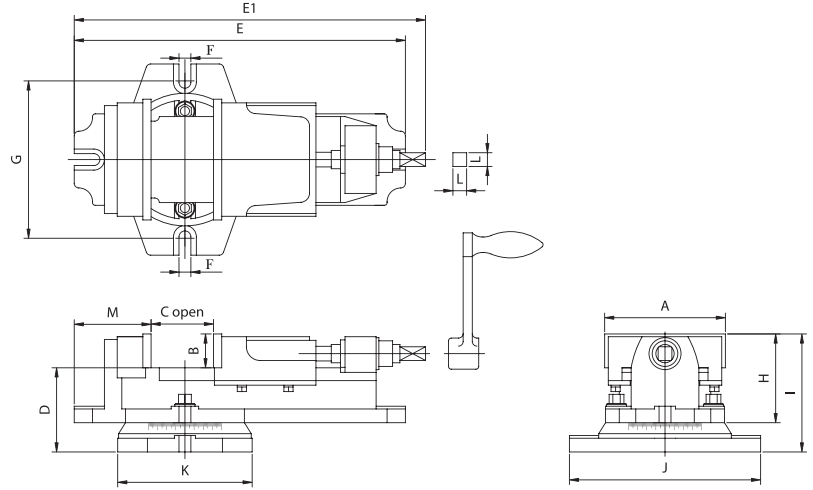

- YÜKSEK HASSASİYET ve KALİTELİ İŞÇİLİĞİ İLE EKİPMANLARIN PRATİK BİR PARÇASIDIR.
- GÖVDE, HAREKETLİ ÇENE ve TABLA SIK TANELİ YÜKSEK MUKAVEMETLİ DÖKME DEMİRDEN İMAL EDİLMİŞTİR. AĞIR İŞLER ve SÜREKLİ HASSASİYET İÇİN ÜRETİLMİŞTİR.
- ÇENE PLEYTLERİ SERTLEŞTİRİLMİŞ ve TAŞLANMIŞ TAKIM ÇELİĞİNDEN İMAL EDİLMİŞTİR.
- EN UYGUN KULLANIM YERLERİ FREZELEME, DELME ve TAŞLAMADIR.
- HASSASİYETİ 0,02 mm'DİR.

DETAYLAR

KOD	A	B	C AÇILIM	D	E	E1	F	G	H	I	J	K	L	M	MAX.KAPANMA gücü (Kg)	AĞIRLIK (Kg)	FİYAT USD
VK-4	104	36	62	76	293	310	13	145	83	113	176	122	15	65	900	10	
VK-5	132	37	80	92	362	384	13	172	97	129	209	147	15	84	900	16	
VK-6	154	43	112	105	442	473	15	209	108	148	260	181	16,5	90	1000	27	
VK-8	204	63	146	127	579	609	18	312	148	190	350	234	21	122	1400	59	

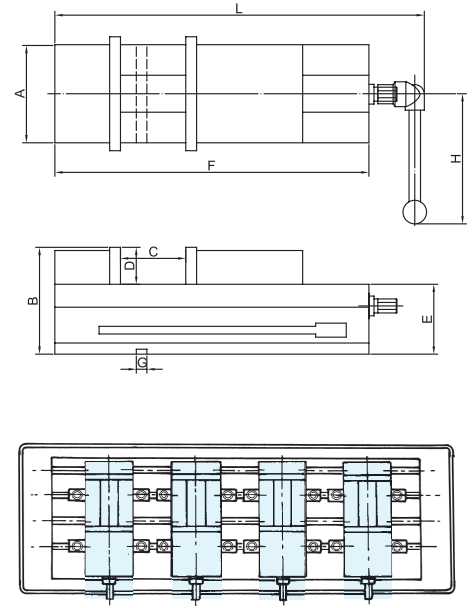
LOCK - FIXED II HASSAS MAKİNA MENGESİ

DETAYLAR

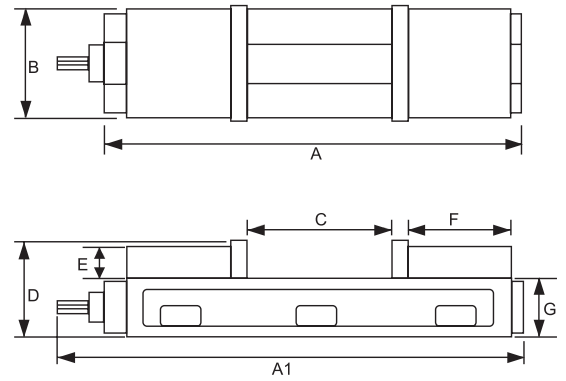
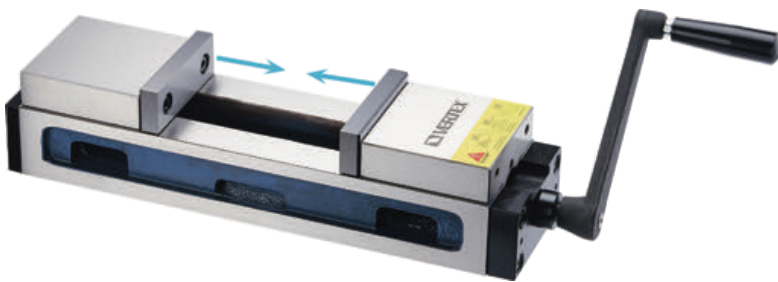
KOD	A	B	C AÇILIM	D	E	F	G	L	H	MAX.KAPANMA GÜCÜ (Kg)	AĞIRLIK (Kg)	FİYAT USD
VMC-4	108	100	110	36	63	283	16	374	202	1500	14.2	
VMC-6	156	120	142	46	74	370	16	472	221	2500	29.8	

BİLEŞİK HASSAS MENGENE

- OTOMATİK MERKEZLEME
- KOMPAKT DİZAYN
- YÜKSEK HASSASİYET
- YÜKSEK AÇILIM KAPASİTESİ
- KABA ve ŞEKİLSİZ PARÇALARA UYGUNDUR
- HIZLI ve GÜVENLİ MERKEZLEME

DETAYLAR

KOD	A	A1	B	C AÇILIM	D	E	F	G	MAX. KAPANMA GÜCÜ (Kg)	AĞIRLIK (Kg)	FİYAT USD
VCV-44	420	469	108	185	98	36	102	62	450	17.7	

3 AÇILI FREZE MENGENESİ

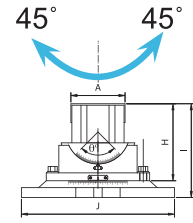
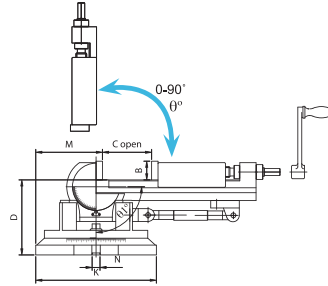
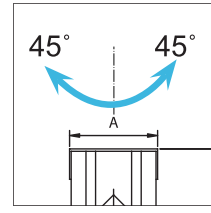
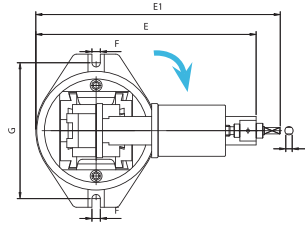
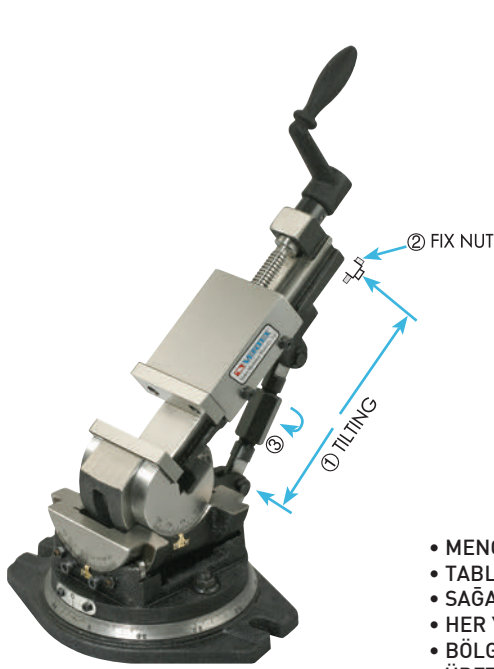

- MENGENE 3 DOĞRULTUDA AYARLANABİLİR.
- TABLA 360° DÖNEBİLİR, YATAY - DİKEY YÖNDE 90° HAREKET EDEBİLİR.
- SAĞA SOLA HER İKİ YÖNE 45° AYARLANABİLİR.
- HER YÖN HAREKETİNDE İŞLEM PARÇASI SAĞLAM BİÇİMDE TUTULUR.
- BÖLGESEL OLARAK VİDANIN KAPANAN KISMI ÖZEL BİR MALZEMEDEN ÜRETİLMİŞ YATAK VASITASIYLA GÜÇLENDİRİLMİŞTİR.

DETAYLAR

KOD	A	B	C AÇILIM	D	E	E1	F	G	H	I	J	K	L	M	N	θ	θ_1	MAX. KAPANMA GÜCÜ (Kg)	AĞIRLIK (Kg)	FİYAT USD
VW-3	80	31	85	126	335	370	15	210	127	157	240	185	10	95	16	-45°~45°	-0°~90°	800	(K) 16.7	
VW-4	110	38	116	152	448	497	17	276	157	190	311	245	13	135	16	-45°~45°	-0°~90°	1000	(K) 32.7	
VW-5	135	40	145	170	530	580	17	310	173	210	358	271	13	140	16	-45°~45°	-0°~90°	1600	(K) 49.4	

2 AÇILI MAKİNA MENGENESİ



- AĞIR DÖKME DEMİR GÖVDE
- HER İKİ DOĞRULTUDA ÖLÇEK
- Z DOĞRULTUSUNDA 360° LİK TABLA
- DİKEY ve YATAY 90° LİK HAREKET

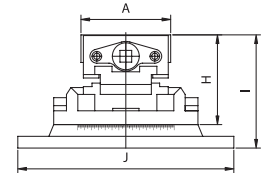
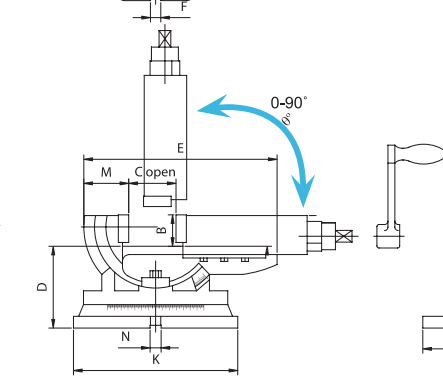
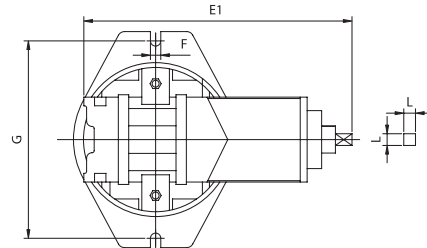

DETAYLAR

KOD	A	B	C AÇILIM	D	E	E1	F	G	H	I	J	K	L	M	N	θ	MAX. KAPANMA GÜCÜ (Kg)	AĞIRLIK (Kg)	FİYAT USD
VWT-5	130	46	100	118	280	415	15	286	130	164	313	238	17	65	16	0°~90°	900	(K) 31.7	
VWT-6A	160	51	120	140	360	510	17	293	150	191	328	252	17	83	16	0°~90°	1600	(K) 47	

2 AÇILI MAKİNA MENGENESİ

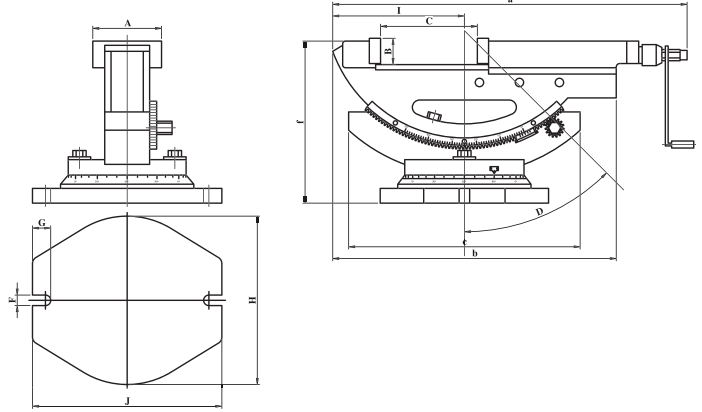

* HİDROLİK SİSTEM DIŞINDAKİ ÖZELLİKLERİ VHT SERİSİ İLE AYNIYDIR.

DETAYLAR

KOD	A	B	C AÇILIM	D	E	F	G	H	I	J	a	b	c	f	MAX. KAPANMA GÜCÜ (Kg)	AĞIRLIK (Kg)	FİYAT USD
VWT-4B	110	36	220	50°	15	15	26	240	185	270	500	404	335	230	1200	(K) 33.3	
VWT-6B	154	54	350	50°	20	19	28	300	246	330	800	585	415	290	1600	(T) 80	

2 AÇILI HİDROLİK MAKİNA MENGENESİ

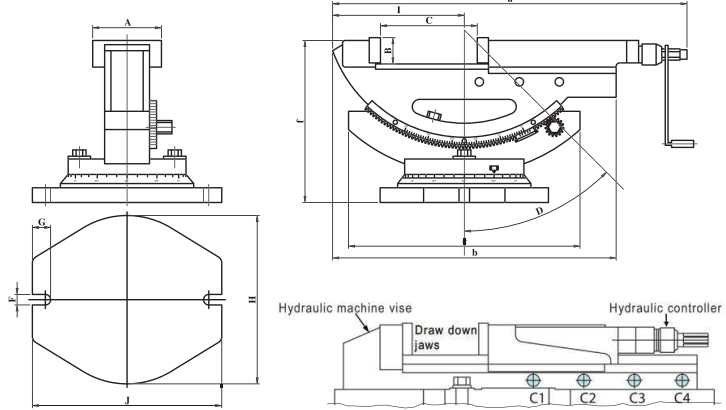
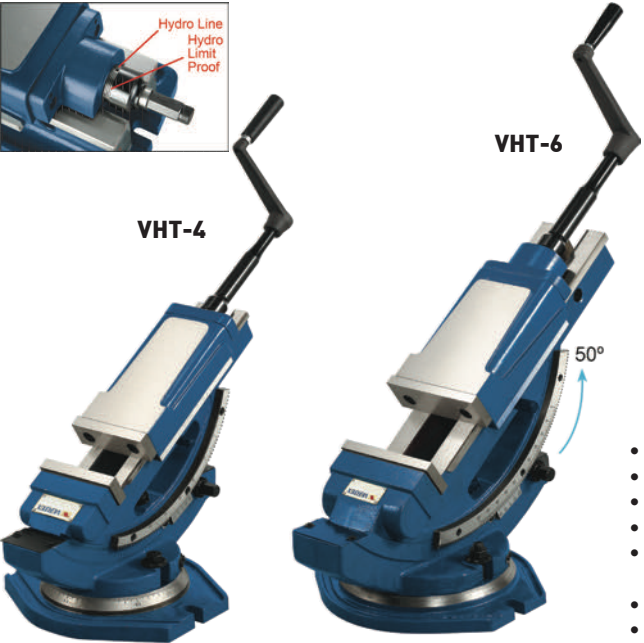
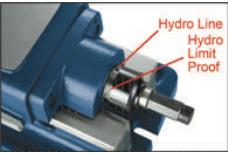

- GENEL OLARAK VH TİP İLE AYNIYDIR.
- HAREKETLİ YATAK SAĞLAMLIK İÇİN İKİ ADET KİLİTLEME VİDASINA SAHİPTİR.
- HAREKET ARALIĞI 0-50°DİR.
- KOLAY OKUNACAK ŞEKİLDE ÖLÇEKLENDİRİLMİŞTİR.
- TABLA 0-360° ARASI HERHANGİ BİR YERDE SABİTLENECEK ŞEKİLDE DERECELENDİRİLMİŞTİR.
- 3 KADEMELİ AÇILMA VH TİPTEKİ GİBİDİR.
- HASSASİYETİ 0,02 mm DİR.

DETAYLAR

KOD	A	B	C AÇILIM	D	E	F	G	H	I	J	a	b	c	f	MAX. KAPANMA GÜCÜ (Kg)	AĞIRLIK (Kg)	FİYAT USD
VHT-4	110	36	170	50°	15	15	26	240	185	270	500	404	335	230	2500	(T) 33.3	
VHT-6	154	54	300	50°	20	19	28	300	246	330	800	585	415	290	4500	(T) 88	

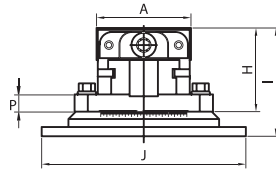
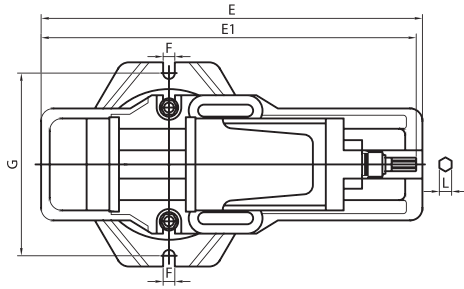
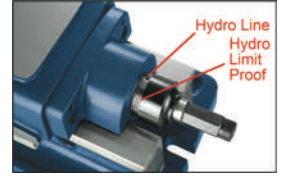
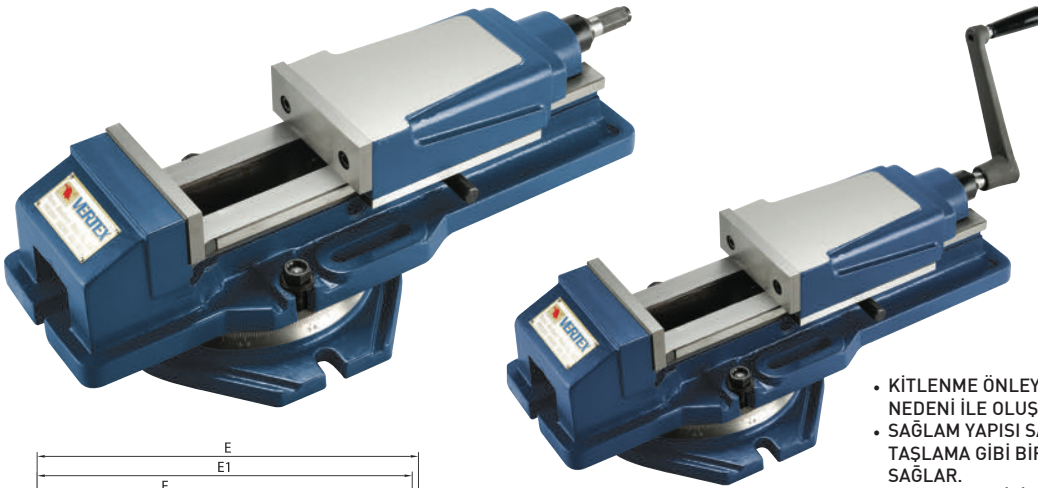
HİDROLİK MENGENE

- KİTLENME ÖNLEYİCİ YENİ SİSTEM, YANLIŞ GÜÇ AYARI NEDENİ İLE OLUŞAN KİTLENMELERİ ÖNER.
- SAĞLAM YAPISI SAYESİNDE DELME, FREZELEME ve TAŞLAMA GİBİ BİR ÇOK İŞLEMDE KULLANILABİLMESİNİ SAĞLAR.
- YALITILMIŞ MİLİ, KİR ve ÇAPAĞA KARŞI KORUNAKLIDIR.
- KAYMA YATAKLARI SERTLEŞTİRİLMİŞ ve TAŞLANMIŞTIR.
- HİDROLİK SİSTEMİ MİNİMUM GÜÇ İLE MAKSİMUM KAPANMA BASINCI SAĞLAR.
- HIZLI KAPANMA ve KİTLENME KOLAY KULLANIM SAĞLAR.
- HASSASİYETİ 0,02 mm'DİR.
- TABLA YA DA TABLASIZ OLABİLİR.
- HİDROLİK İTİCİ SİSTEMİ 1 YIL KULLANIM GARANTİLİDİR.
- 68 NOLU HİDROLİK YAĞ KULLANILIR. HİDROLİK İTİCİ SİSTEM ARIZALARINA KARŞI KULLANIM KILAVUZUNA BAKINIZ.

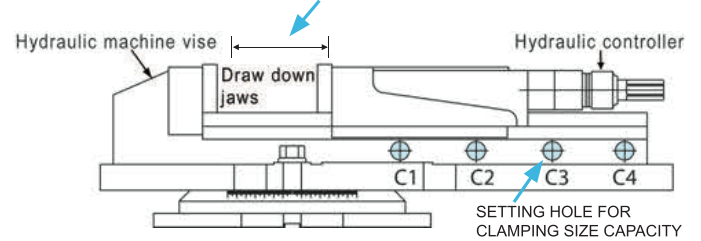
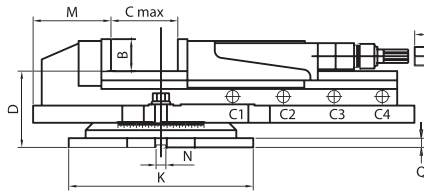
DETAYLAR

KOD	A	B	C AÇILIM	AÇILMA KAPASİTESİ				D	E	E1	F	FİYAT USD
				C1	C2	C3	C4					
VH-4	108	36	175	0-63	61-120	118-175	----	98	443	583	14	
VH-5	132	48	220	0-75	73-150	148-210	----	113	550	703	17	
VH-6	151	52	300	0-100	98-200	198-300	----	124	620	800	19	
VH-8	204	62	300	0-100	98-200	198-300	----	144	680	857	17	
VH-8L	204	62	400	0-100	98-200	198-300	298-400	144	795	950	17	

DETAYLAR

KOD	G	H	I	J	K	L	M	N	O	P	MAX. KAPANMA GÜCÜ (Kg)	AĞIRLIK (Kg)
VH-4	235	95	135	270	240	14	110	16	156	22	2500	28
VH-5	253	118	161	290	263	19	124	16	165	22	4500	47
VH-6	298	136	176	332	300	19	126	16	200	30	4500	63
VH-8	342	162	206	375	350	19	155	16	200	30	7500	110
VH-8L	342	262	206	375	350	19	155	16	200	30	7500	108

DÖNER TABLA

KOD	a	b	c	n	Ø	AĞIRLIK (Kg)	FİYAT USD
HS-4	280	210	30	16	15	4	
HS-5	297	267	43	16	20	7	
HS-6	335	310	40	16	20	10	
HS-8	373	355	45	16	22	16	

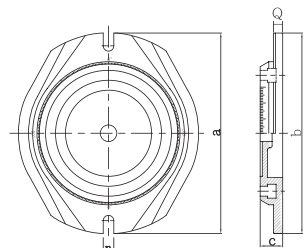

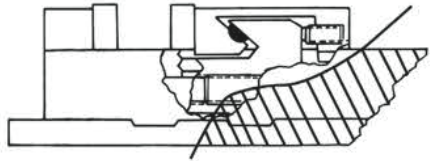
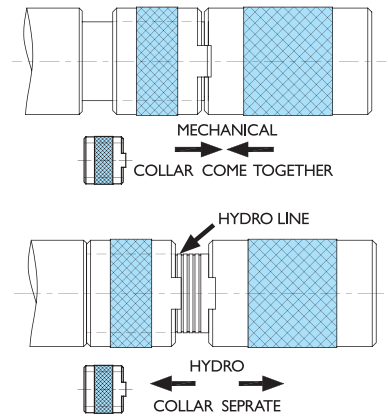
HİDROLİK MAKİNA MENGENESİ

**MEKANİK KULLANIM
PİRİNÇ, ALÜMİNYUM, PLASTİK,
ÇELİK ve DÖKÜM İŞLEME İÇİN
UYGUNDUR.**

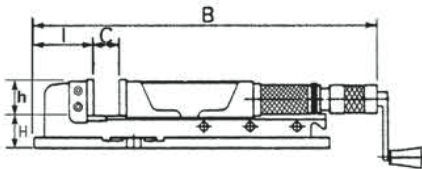
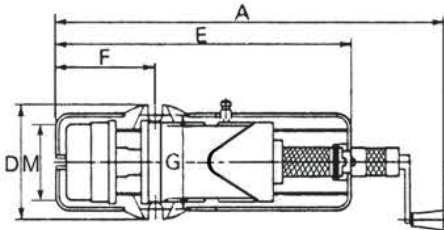

- HİDRO ÇİZGİSİNİ GÖRENE KADAR ÇEVİRME AKSINI ÇEVİRİN.
- ÇEVİRME AKSINI HİDRO ÇİZGİSİ KAPANINCAYA KADAR ÇEVİRİN.
- ZORLUK GEREKTİREN KESİMLERDE KULLANILABİLİR
- SERTLİK HRC45
- MÜKEMMEL DAYANIKLILIK ve YÜKSEK HASSASİYET
- TOLERANS 0,01/100mm
- TİTREŞİMİ MİNİMİZE EDEN YÜKSEK KALİTE SÜNEK DÖKME DEMİR MALZEMEDEN ÜRETİLMİŞTİR.

DETAYLAR

KOD	A	B	C AÇILIM	D	E	F	G	H	I	M	h	w	MAX. KAPANMA GÜCÜ (Kg)	AĞIRLIK (Kg)	FİYAT USD
VHO-5	695 920	545 775	0-220	190	505	180	160	74	105	130	55	130	3500	36,5	
VHO-6	750 1060	600 915	0-300	240	625	208	196	80	125	160	58	160	4000	59,1	
VHO-8	830 1140	700 1015	0-310	280	700	265	240	100	165	200	63	200	5000	94,3	

DÖNER TABLA

KOD	A	B	C	N	Ø	AĞIRLIK (Kg)	FİYAT USD
HSO-5	285	263	35	16	20	12,5	
HSO-6	330	320	40	18	20	16,5	
HSO-8	415	413	50	21	22	35	

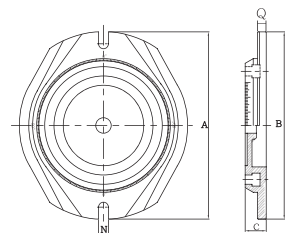

NC HİDRO MAKİNA MENGENESİ

- HİDRO İTİCİ SİSTEM MİNİMUM GÜÇ İLE MAKSİMUM KAPANMA BASINCI SAĞLAR.
- KAYMA YATAKLARI TAŞLANMIŞ ve SERTLEŞTİRİLMİŞTİR.
- KOMPAKT YAPIDADIR. KAPANMA KAPASİTESİ HARİKADIR.
- GÖVDE FCD60 SÜNEK DÖKME DEMİRDEN ÜRETİLMİŞTİR.
- AKMA ve DARBE DAYANIMI YÜKSEKTİR.
- FREZEDEN DELMEYE, TAŞLAMAYA BİRÇOK OPERASYONA UYGUN OLARAK YAPILANDIRILMIŞTIR.

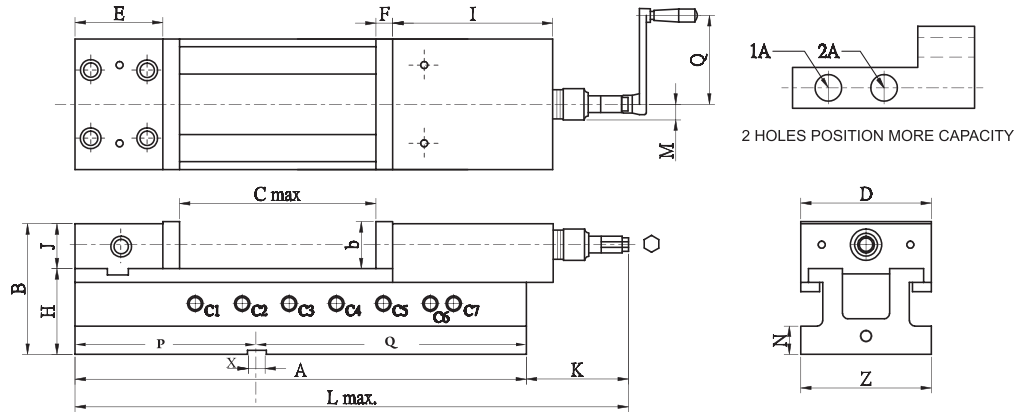
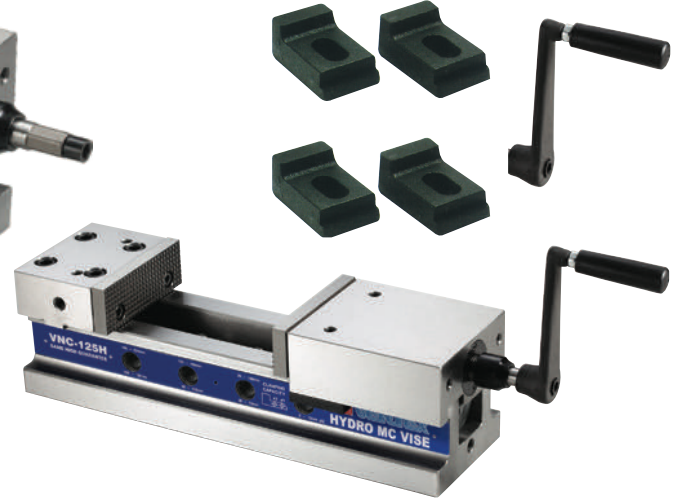

DETAYLAR

KOD	C AÇILIM	KAPANMA GÜCÜ KN	L max	AÇILMA KAPASİTELERİ								FİYAT USD
				-	C1	C2	C3	C4	C5	C6	C7	
VNC-100H	205	25	464	1A	2-30	57-90	115-146	173-205	-	-	-	
				2A	0-3	28-60	86-116	145-175	-	-	-	
VNC-125H	225	40	556	1A	10-46	70-106	130-166	190-226	-	-	-	
				2A	0-12	38-72	98-132	158-192	-	-	-	
VNC-160H	309	50	684	1A	13-70	93-150	173-230	253-310	-	-	-	
				2A	0-30	53-110	133-190	213-270	-	-	-	
VNC-160LH	509	50	884	1A	13-70	93-150	173-230	253-310	333-390	410-470	450-510	
				2A	0-30	53-110	133-190	213-270	293-350	370-430	410-470	

DETAYLAR

KOD	A	B	D	E	F	b	H	J	N	I	Z	X	P	Q	AĞIRLIK (Kg)
VNC-100H	380	107	100	67	13	38	70	37	24	133	100	14	152	228	19
VNC-125H	432	126	124	85	15	45	82	44	27	147	125	18	174	258	37
VNC-160H	550	148	159	102	18	54	95	53	27	189	160	18	219	331	63
VNC-160LH	750	148	159	102	18	54	95	53	27	189	160	18	219	531	77

MEKANİK MC MENGENE



* MAFSAL DESTEKLİ MEKANİZMASI AĞIR İŞLER İÇİN TASARLANMIŞTIR.

- KOMPAKT DİZAYN
- RIJİT ve YÜKSEK KAPANMA GÜCÜ
- MAFSAL DESTEKLİ MEKANİZMA İŞLEME PARÇASINI, İÇ YAPISINDAKİ DİSK YAYI İLE ESNEK BİÇİMDE TUTTUĞU SÜRECE TİTREŞİM ve ŞOKLARA KARŞI SÜREKLİ BİR KAPANMA GÜCÜ SAĞLAR
- YÜKSEK KAPANMA GÜCÜ

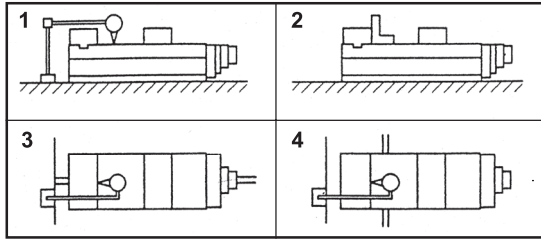
- GENİŞ ÇENE DARBE ARALIĞI
- GÖVDE FCD60 YÜKSEK KALİTELİ SÜNEK DÖKME DEMİR'DEN İMAL EDİLMİŞTİR.
- DARBE ve AKMAYA DİRENÇLİDİR.
- HAREKETLİ KAYMA YATAKLARI SERTLEŞTİRİLMİŞ ve TAŞLANMIŞTIR.
- İÇ MEKANİZMASI TALAŞ ve KİRE KARŞI KORUNMUŞTUR.
- HIZLI KAPANMA ve KİLİTLENME SİSTEMİ İLE KOLAY KULLANIMLIDIR.

TEST DETAYLARI

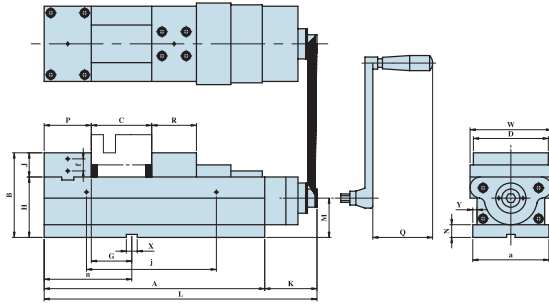
NO.	TEST CİNSİ (HER 100 mm İÇİN)	GARANTİ EDİLEN DEĞERLER
1	PARALELLİK: HAREKETLİ YÜZEY İLE TABAN YATAĞI	0,01/100 mm
2	KARESELLİK: HAREKETLİ YÜZEY İLE ÇENE PLEYTİ	0,02/100 mm
3	KARESELLİK: ÇENE PLEYTİ YATAĞINDAKİ ANAHTAR YOLLARI	0,02/100 mm
4	PARALELLİK: HAREKETLİ YÜZEYDEKİ TEST BLOĞU İLE YATAK YÜZEYİ	0,02/100 mm

KAPANMA KAPASİTELERİ

KOD	ÇENE	ÇENE AÇILIM	B	MAX. KAPANMA GÜCÜ (KN)	AĞIRLIK (Kg)
	H	C			
VQC-125	40	205	140	40	40.4
VQC-160	45	275	165	60	72.3
VQC-160L	45	355	165	60	78.6
VQC-200L	70	405	190	60	108

DETAYLAR

KOD	A	B	a	D	P	R	G	H	J	K	L
VQC-125	366	140	126	124.5	78	74	66	100	40	86	452
VQC-160	456	165	161	159.5	86	86	58	120	45	98	554
VQC-160L	536	165	162	160	86	86	58	120	45	98	634
VQC-200L	616	180	202	200	102	98	74	120	70	95	711

DETAYLAR

KOD	M	N	Q	W	X	Y	ÇENE AÇILIM	f	J	n	FİYAT USD
							C				
VQC-125	65	21	74	135	18	7	205	20	216	145	
VQC-160	78	21	94	170	18	7	275	20	286	145	
VQC-160L	78	21	94	174	18	7	355	20	286	145	
VQC-200L	75	21	96	217	18	7	405	20	386	177	

HİDROLİK MC MENGENE

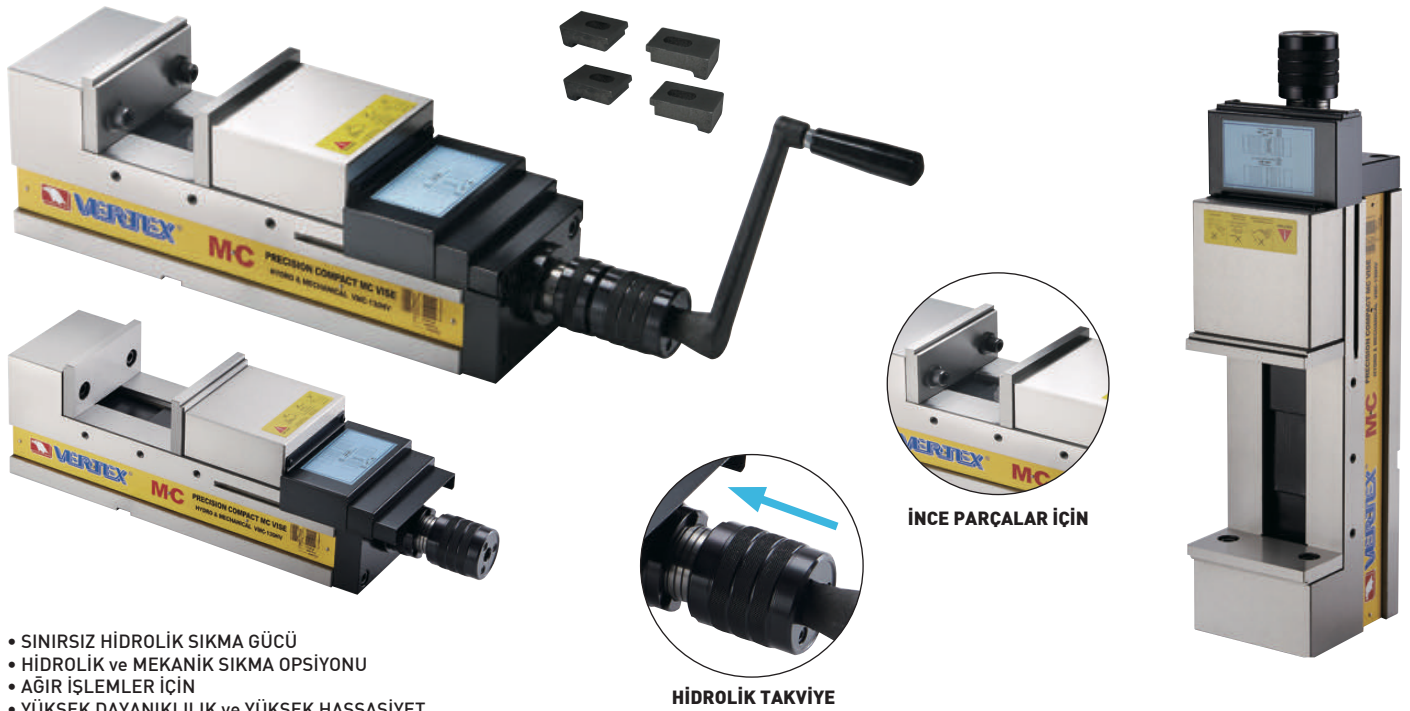

- SINIRSIZ HİDROLİK SIKMA GÜCÜ
- HİDROLİK ve MEKANİK SIKMA OPSİYONU
- AĞIR İŞLEMLER İÇİN
- YÜKSEK DAYANIKLILIK ve YÜKSEK HASSASİYET
- TALAŞ GEÇİRMEZ GİZLİ MİL
- HIZLI ve KOLAY OPERASYON
- ESNEME DİRENCİ SABİT ve KUVVETLİ
- SERTLİK HRC45
- TOLERANS 0,01/100mm
- TİTREŞİME ABSORBE EDEN FCD-60 YÜKSEK KALİTE YUMUŞAK DÖKÜM GÖVDE
- SABİT AÇILI DİZAYNI SAYESİNDE YATAY-DİKEY KESİMLERDE ve İŞLEME MERKEZLERİNDE UYGUN KULLANIM

HASSASİYET TESTİ STANDARTLARI

NO.	KONU	GARANTİ EDİLEN DEĞERLER
1	YAN KANALLAR İLE YATAK HASSASİYETİ	0,010/100 mm
2	TABAN KAMA KANALLARI İLE ÇENELERİN HASSASİYETİ	0,015/100 mm
3	ÇENELERİN BİRBİRİNE GÖRE PARALELLİĞİ	0,020/100 mm
4	TAM AÇILIM ANINDA TEST BLOĞUNUN MENGENE TABANINA GÖRE PARALELLİĞİ	0,030/100 mm
5	MENGENE YATAK YÜZEYİNİN TABANA GÖRE PARALELLİĞİ	0,015/100 mm

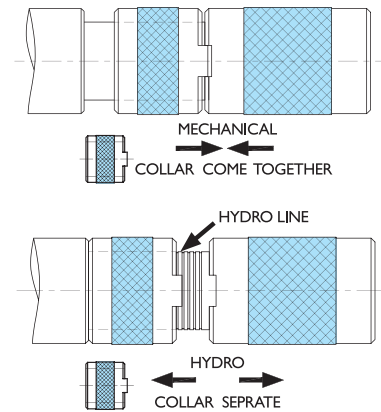
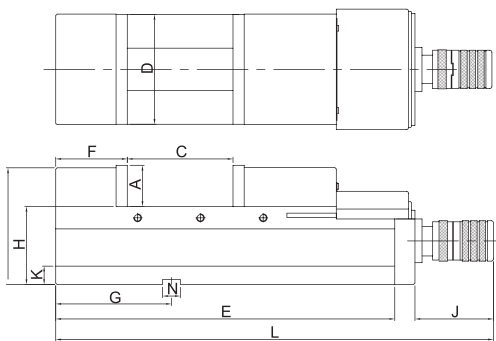

DETAYLAR

KOD	A	B	C AÇILIM	D	E	F	G	H	J	K	L	M	N	KAPANMA GÜCÜ (Kg)	AĞIRLIK (Kg)	FİYAT USD
VMC-100HV	48	130	125	100	340	80	125	85	110	15	470	101	16	3000	27	
VMC-130HV	55	147	180	130	405	85	150	95	110	21	535	131	18	4000	40	
VMC-160HV	58	168	240	160	495	100	165	105	110	21	625	161	18	5000	58	
VMC-200HV	61	170	280	200	570	108	190	110	110	21	700	201	18	6000	87	

TEL EROZYON MENGENESİ (PASLANMAZ)

VSTV-50W

- EROZYON KESME TEZGAHLARINDA KULLANILIR.
- TÜM PARÇALAR PASLANMAZ ÇELİK ve YÜKSEK EROZYONA DİRENÇLİ OLARAK İMAL EDİLMİŞTİR.
- MALZEME SUS440

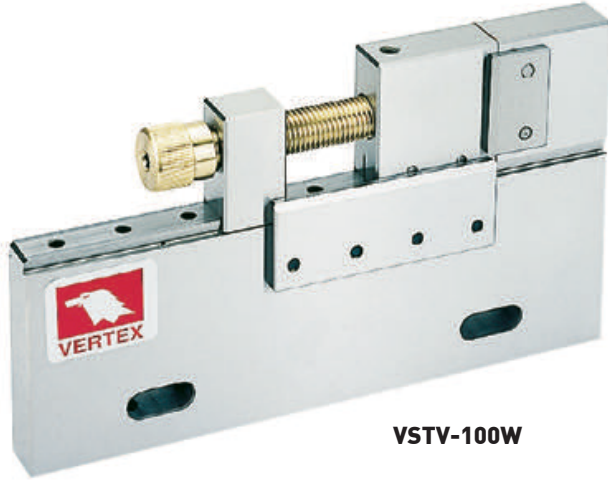
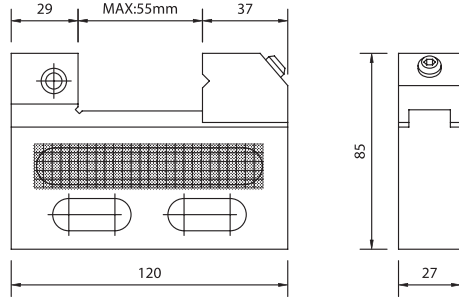
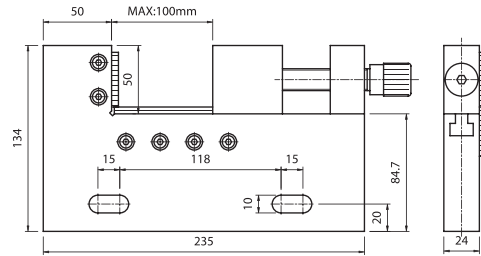
VSTV-100W

DETAYLAR

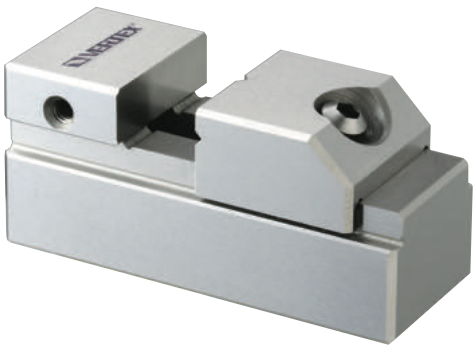
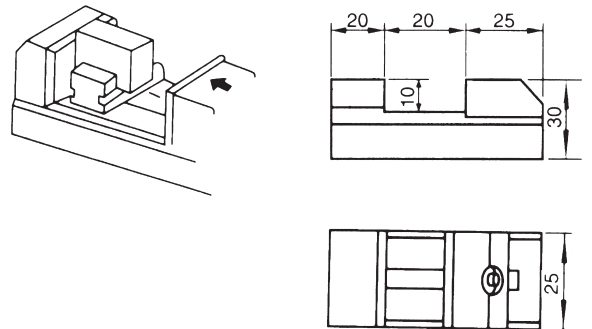
KOD	PARALELLİK	KARESELLİK	AÇILIM	KALINLIK	ÇENE DERİNLİĞİ	AĞIRLIK (Kg)	SERTLİK	FİYAT USD
VSTV-50W	±0,002/100	±0,002/100	55	27	25	1,4	HRC54°±2°	
VSTV-100W	±0,002/100	±0,002/100	100	24	50	4,88	HRC54°±2°	

MİNİ PİMLİ HASSAS TEZGAH MENGENESİ

AĞIRLIK : 0,3 Kg

KOD	FİYAT USD
VMV-10	

- MİNİ TİP PİMLİ HASSAS TEZGAH MENGENESİ DAHA BÜYÜK MENGENELERİN İÇİNE BAĞLANARAK, HASSAS PARÇALARIN İŞLENMESİNE OLANAK SAĞLAR.
- KARESELLİK ve PARALELLİK 0,005mm

PİMLİ HASSAS TEZGAH MENGENESİ



- SERTLEŞTİRİLMİŞ HASSAS ZEMİN
- KARESELLİK ve PARALELLİK $\pm 0,005$
- PARÇA MENGENE ÜZERİNE, YANINA VEYA KENARINA HASSAS ŞEKİLDE BAĞLANABİLİR.
- MENGENE İŞLEMLERİNDE İSTER TABANI, İSTER KENARLARI, İSTER KÖŞELERİ ÜSTÜNDE DURSUN, ZEMİNİ KORUR

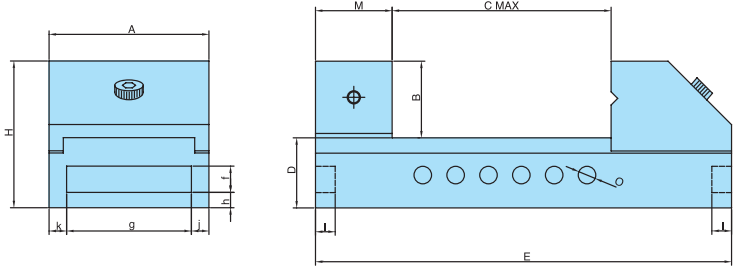

DETAYLAR

KOD	A	B	C AÇILIM	D	E	f	g	h	j	k	H	M	O	SERTLİK	AĞIRLIK (Kg)	FİYAT USD
VMV-15	36	20	40	20	100	5	8	24	5	6	40	20	6	HRC54° $\pm 2^\circ$	0.9	
VMV-20	47	29	70	28	150	5	10	37	6	5	57	30	8	HRC54° $\pm 2^\circ$	2	
VMV-25	62	34	84	28	170	7	10	52	6	5	62	30	8	HRC54° $\pm 2^\circ$	3.3	
VMV-30	72	34	98	32	190	9	12	56	7	8	66	35	8	HRC54° $\pm 2^\circ$	4.5	
VMV-35	88	45	125	40	230	12	12	64	11	12	85	40	10	HRC54° $\pm 2^\circ$	7	
VMV-40	98	45	130	40	235	12	12	64	11	17	85	40	10	HRC54° $\pm 2^\circ$	8.9	
VMV-50	125	50	150	50	287	12	13	73	14	26	100	50	14	HRC54° $\pm 2^\circ$	15.5	
VMV-60	150	50	200	50	330	12	14	76	14	37	100	50	14	HRC54° $\pm 2^\circ$	21.4	

VİDALI HASSAS TEZGAH MENGENESİ

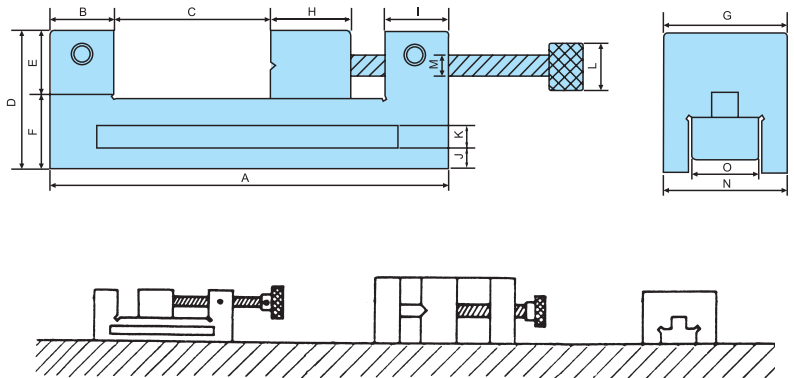
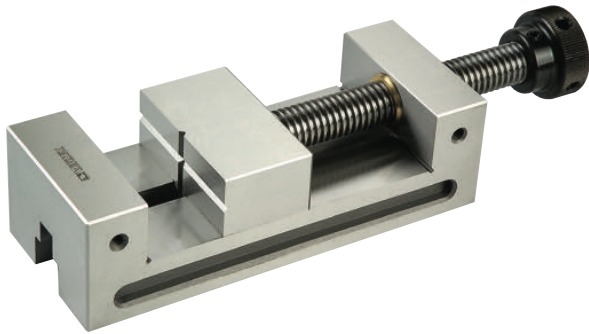

DETAYLAR

KOD	A	B	C AÇILIM	D	E	F	G	H	I	J	K	L	M	N	O	SERTLİK	AĞIRLIK (Kg)	FİYAT USD
VDV-20	155	25	55	54	25	29	48	45	25	10	10	35	16	48	19	HRC54° $\pm 2^\circ$	2,5	
VDV-25	176	25	75	60	30	30	63	45	25	10	11	40	16	63	26	HRC54° $\pm 2^\circ$	3,9	
VDV-30	181	30	71	70	30	40	73	52	25	14	13	50	19	73	26	HRC54° $\pm 2^\circ$	5,7	
VDV-35	250	35	121	73	38	35	88	55	35	11	12	55	25	88	30	HRC54° $\pm 2^\circ$	9,2	
VDV-40	250	35	121	73	38	35	98	55	35	12	12	55	25	98	30	HRC54° $\pm 2^\circ$	10,1	

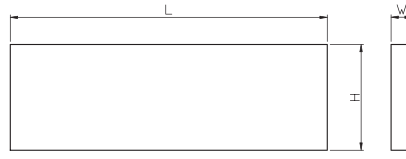
PARALEL SET 9 ÇİFT (SİPARİŞ NO: VP-100)

HASSASİYET 0,01 mm

- DAHA GÜVENLİ FREZE MENGENESİ İŞLEMLERİ İÇİN
- SERTLİK HRC 48-53
- 4 TARAFI TAŞLANMIŞ
- 1 SET 18 PARÇA İÇERİR
- PLASTİK KUTUDADIR
- BRÜT AĞIRLIK 11,5 Kg

DETAYLAR

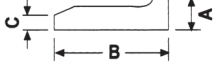
GÖVDE ÖLÇÜSÜ	KAPANMA ÖLÇÜSÜ
WxHxLxAdet	AxBxCxLxAdet
5x16x100x2	15x31x2,5x200x2 
6x18x100x2	
8x24x100x2	
10x30x100x2	
12x36x150x2	
14x48x150x2	
18x60x150x2	
22x62x150x2	
FİYAT USD	

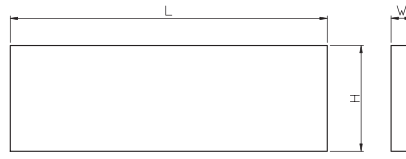
PARALEL SET 14 ÇİFT (SİPARİŞ NO: VP-128A 10mm GENİŞLİK)

HASSASİYET 0,01 mm

- SERTLİK HRC 48-53
- SERTLEŞTİRİLMİŞ ve TAŞLANMIŞTIR
- YÜKSEK ALAŞIMLI ÇELİKTE İMAL EDİLMİŞTİR
- 1 SET 28 PARÇA İÇERİR
- BRÜT AĞIRLIK 10.7 Kg

DETAYLAR

WxHxLxAdet	
10x14x150x2	10x28x150x2
10x16x150x2	10x30x150x2
10x18x150x2	10x32x150x2
10x20x150x2	10x35x150x2
10x22x150x2	10x40x150x2
10x24x150x2	10x45x150x2
10x26x150x2	10x50x150x2
FİYAT USD	

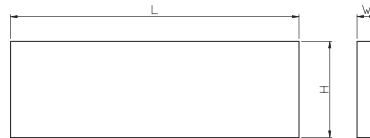
PARALEL SET 9 ÇİFT (SİPARİŞ NO: VP-200)

HASSASİYET 0,01 mm

- SERTLİK HRC 48-53
- SERTLEŞTİRİLMİŞ VE TAŞLANMIŞTIR
- YÜKSEK ALAŞIMLI ÇELİKTE İMAL EDİLMİŞTİR.
- 1 SET 18 PARÇA İÇERİR
- BRÜT AĞIRLIK 15,4 Kg

DETAYLAR

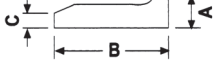
GÖVDE ÖLÇÜSÜ	KAPANMA ÖLÇÜSÜ
AxBxLxAdet	AxBxCxLxAdet
5x16x150x2	15x31x2,5x200x2 
6x18x150x2	
8x24x150x2	
10x30x150x2	
12x36x200x2	
14x48x200x2	
18x60x200x2	
22x62x200x2	
FİYAT USD	

KÖRÜKLÜ MAKİNA KORUYUCU

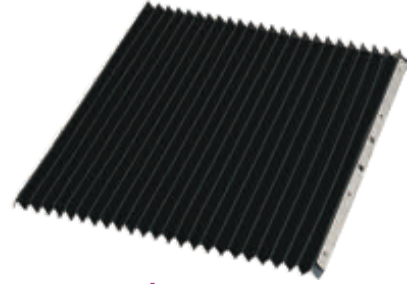
B TİP

F TİP
F: ÖN TARAF İÇİN (X)
B: ARKA TARAF İÇİN (Y) (FREZE)
B SERİSİ KAUÇUK DÜZELTİLMİŞ TİPTİR.
DETAYLAR

KOD	WxL	UYGUN OLAN MAKİNA	AĞIRLIK (Kg)	FİYAT USD
VGC-3833F	380x330	1.5"	0.3	
VGC-3860F	380x600	1.6"-1.7"	0.6	
VGC-4550F	450x500	1.6"	0.7	
VGC-3775B	370x750	1.5"	0.7	
VGC-4585B	450x850	1.6"-1.7"	1.1	
VGC-6085B	600x850	2.0"	2	

52 PARÇA KALIP BAĞLAMA SETİ

ISIL İŞLEM GÖRMÜŞ ÇELİKTEN İMAL EDİLMİŞTİR.
SET İÇERİĞİ

- 24 ADET SAPLAMA (75/100/125/150/175/200 mm)
- 6 ADET T-SOMUN
- 4 ADET EŞLEME SOMUNU
- 6 ADET FLANŞ SOMUNU
- 6 ADET PABUÇ KİLİDİ
- 6 ADET PABUÇ BLOĞU

DETAYLAR

KOD	TABLA YUVASI	CİVATA ÖLÇÜSÜ	AĞIRLIK (Kg)	FİYAT USD
CK-08	10	M8-1.25P	7,4 (K)	
CK-10	12	M10-1.5P	7.6 (K)	
CK-12A	14	M12-1.75P	9.4 (K)	
CK-14	16	M14-2.0P	11.1 (K)	
CK-16	18	M16-2.0P	12.6 (K)	
CK-18	20	M18-2.5P	25.3 (K)	
CK-20	22	M20-2.5P	27 (K)	

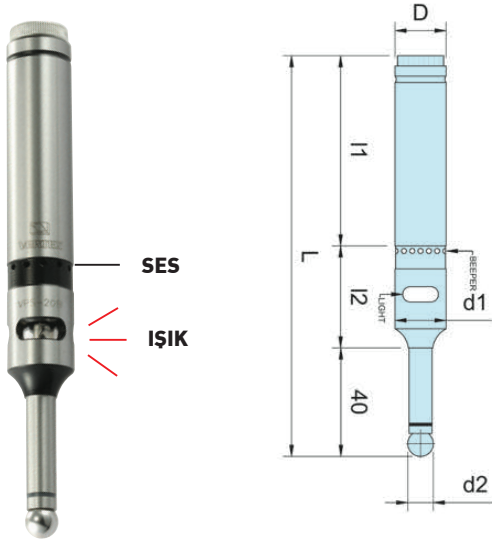
İŞIKLI SESLİ PROPLAR

- ÖLÇÜM SIRASINDA DÖNDÜRMEYE GEREK YOKTUR.
- SUDAN ETKİLENMEZKEN İŞİĞİNİDA KORUR.
- KIRMIZI İŞIK YANARKEN AYNI ANDA SES ÇIKARTIR.
- İŞIK GÖRÜŞ ALANI DIŞINDA İSE SESLİ UYARI KULLANICIYI UYARIR.
- HASSASİYET 0,005 mm İÇERSİNDEDİR.

DETAYLAR

KOD	D	d1	d2	L	l1	l2	PİL TİPİ	AĞIRLIK (Kg)	FİYAT USD
VPS-20B	Ø20	18	10	160	79	41	UM-5#[SP] x1ADET/12V	0.4	
VPS-32B	Ø32	18	10	160	79	41		0.7	

İŞIKLI PROPLAR

- YÜKSEK HASSASİYETLİ SENSÖRLERİ VARDIR.
- KIRMIZI İŞIK RAHATÇA GÖRÜLEBİLİR.
- BİTİŞ YÜZEYİNİN YERİ, DIŞ ÇAP, İÇ ÇAP GİBİ BİRÇOK ÖLÇÜ BÜYÜK ETKİNLİKLE SAPTANABİLİR.
- PROP UCUNDAKİ TOP, CİHAZA BİR YAY VASITASIYLA BAĞLANMIŞTIR. BU SAYEDE FAZLA HAREKET AVANTAJI SAĞLANIR.
- TOP MERKEZ NOKTAYA DÖNDÜĞÜNDE YÜKSEK HASSASİYETLİ ÖLÇÜM ELDE EDİLİR.

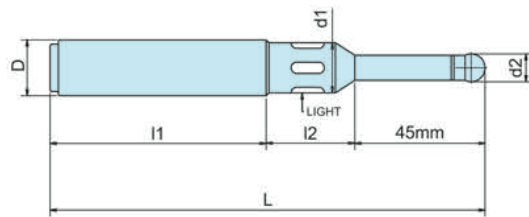
DETAYLAR

KOD	D	d1	d2	L	l1	l2	PİL TİPİ	AĞIRLIK (Kg)	FİYAT USD
VPS-20	Ø20	16	10	157	77	35	UM-5#[SP] x2P/R1./1,5V	0.4	
VPS-32	Ø32	16	10	157	71	41		0.7	

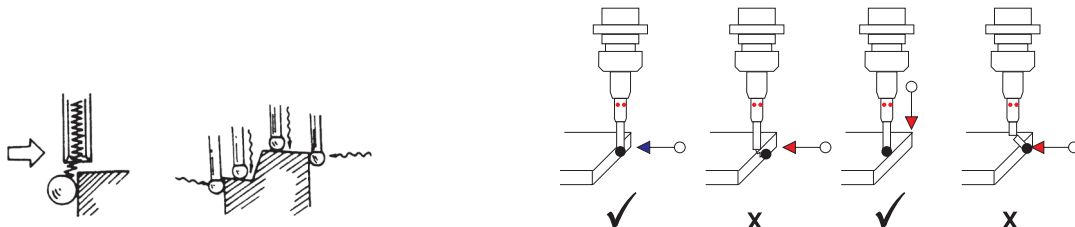

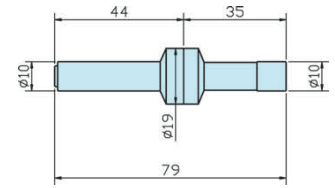
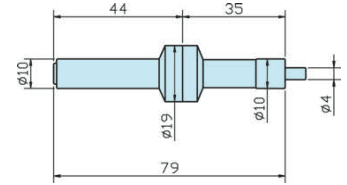
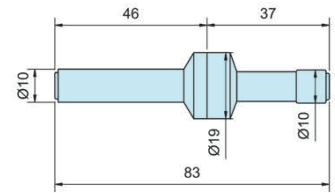
MEKANİK PROP
**VPS-301 ÇELİK
VPS-301S PASLANMAZ**

**VPS-302 ÇELİK
VPS-302S PASLANMAZ**

VPS-301C SERAMİK

- TEKRARLAMA HASSASİYETİ 0,003 mm İÇERSİNDEDİR.
- DEVİR 450-600 ARASINDADIR.
- NET GÖRÜŞ İÇİN DİZAYN EDİLMİŞTİR.

DETAYLAR

KOD	MALZEME	SERTLİK	AĞIRLIK (Kg)	FİYAT USD
VPS-301	ALAŞIMLI ÇELİK	HRC 56°	0.06	
VPS-302		HRC 56°	0.05	
VPS-301S	PASLANMAZ	HRC 60°	0.06	
VPS-302S		HRC 60°	0.06	
VPS-301C	SERAMİK	HRC 60°	0.06	

ELMAS UÇLU SABİT PUNTA

- ELMAS UÇ SERTLİĞİ HRC70
- SERTLEŞTİRİLMİŞ ve HASSAS TAŞLANMIŞTIR.
- EŞMERKEZLİLİK= 0,002" (0,005mm) İÇİNDEDİR.
- DIN 806

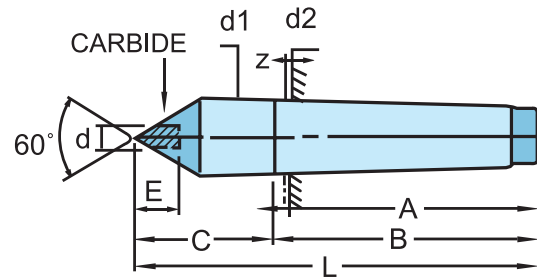
DETAYLAR

KOD	ÖLÇÜ	L	A	B	C	E	d2	d1	d	AĞIRLIK (Kg)	FİYAT USD
VLC-112	MK2	100	69	67	31	8	17.780	18.0	6	0.2	
VLC-113	MK3	125	89	81	39	10	23.825	24.1	8	0.4	
VLC-114	MK4	155	109	102.5	46	14	31.267	31.6	10	0.8	
VLC-115	MK5	200	136	129.5	64	18	44.399	44.7	14	2.1	
VLC-116	MK6	270	190	182	80	30	63.648	63.8	18	5.7	

MANYETİK TABANLI YÜKSEKLİK HİZALAMA (SAATLİ)

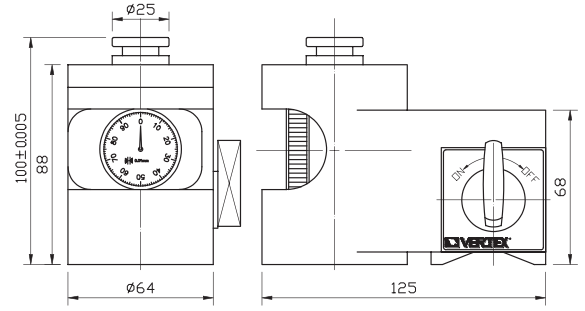

- YÜKSEKLİK HİZALAMAYI İŞ PARÇASININ UYGUN BİR REFERANS YÜZEYİNE YERLEŞTİRİN.
- Z EKSENİNDE KESİCİ TAKIMI YAVAŞÇA AŞAĞI İNDİRİN. DAHA SONRA KESİCİ ÖLÇÜM POZİSYONUNA GELECEKTİR.
- BÖYLECE PARÇA REFERANS YÜZEYİ İLE KESİCİ TAKIMIN ARASINDAKİ MESAFE HASSAS ve KOLAYLIKLA ÖLÇÜLECEKTİR.
- YÜKSEKLİK HİZALAMA BİR ÇOK MAKİNADA UYGULANABİLİR OLUP, NC TORNA ve FREZELERDE DE KULLANILABİLİR.
- YÜKSEKLİK HİZALAMA YATAY ve DİKEY OLARAK KULLANILABİLİR.

DETAYLAR

KOD	REFERANS YÜZEYDEN YÜKSEKLİK	AĞIRLIK (Kg)	FİYAT USD
HP-100	100 mm	2.6	

YÜKSEKLİK HİZALAMA (SAATLİ)



HP-50A

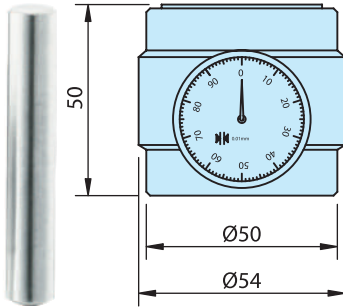

HP-50B

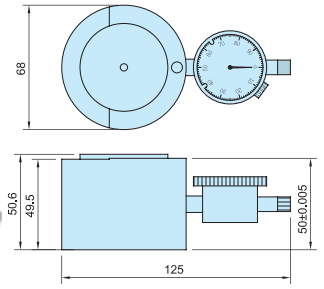

- YÜKSEKLİK HİZALAMAYI TABLA ÜZERİNE YERLEŞTİRDİKTEN SONRA ÜZERİNE DÜZ BİR PARÇA KOYUN ve SAATİ ELLE ÇEVİREREK "0" KONUMUNA GETİRİN.
- DAHA SONRA KESİCİ TAKIMI YÜKSEKLİK HİZALAMAYA DEYDİRİN. SAAT "0" KONUMUNA GELDİĞİNDE TABLA İLE KESİCİ TAKIM ARASINDAKİ MESAFE 50mm' DİR.
- TOLERANS $\pm 0,005$ mm

DETAYLAR

KOD	YÜKSEKLİK	STİL	AĞIRLIK (Kg)	FİYAT USD
HP-50A	50 mm	STANDART TİP	1,1	
HP-50B	50 mm	STANDART TİP	1,7	
HP-50AM	50 mm	MANYETİK TABAN	1,2	
HP-50BM	50 mm	MANYETİK TABAN	1,7	

YÜKSEKLİK SIFIRLAMA (Z EKSEN) OPTİK TİP



HP-50Z

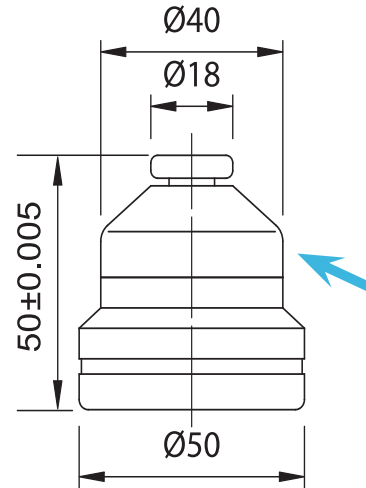

- YÜKSEKLİK 50mm
- MANYETİK TABANLI
- DOKUNDUĞUNDA KIRMIZI IŞIK YANAR
- HASSASİYET 0.005mm
- YATAY ve DİKEY HİZALAMA TEK ALETTE
- AĞIRLIK 0,7 Kg
- LR44 PİL 1 SET 2 ADET

DETAYLAR

KOD	STANDART TİP	MANYETİK TABANLI
	HP-50Z	HP-50ZM
FİYAT USD		

ÇAPAK KORUYUCU



- AYARLANABİLİR SIKMA YÜKSEKLİĞİ ve PİRİNÇ TABLASI İLE DARBELERE KARŞI DAYANIKLIDIR

DETAYLAR

KOD	ÖLÇÜ	AĞIRLIK (Kg)	FİYAT USD
VH-56	300x180x2	1,1	

MANYETİK TABANLI ÇAPAK KORUYUCU

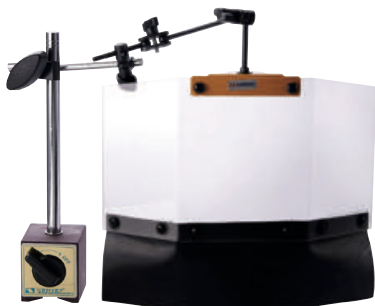

- MANYETİK AYAK 80Kg, 60x50x55mm

DETAYLAR

KOD	ÖLÇÜ	AĞIRLIK (Kg)	FİYAT USD
VH-57	300x180x2	1,6	

MANYETİK TABANLI ÜRÜNLER

2X BÜYÜTEÇ

SİPARİŞ NO. VML-M
MANYETİK AYAKLI BÜYÜTEÇ
M8x1.25p, 80Kg



SİPARİŞ NO. VMB-12
12 mm DELİKLİ TAŞ DÜZELTME
MANYETİK TABAN
(TAŞ DÜZELTME DAHİL DEĞİLDİR)



SİPARİŞ NO. VMB-00
KÜÇÜK BOY MANYETİK TABAN
M8x1.25p, 80Kg



SİPARİŞ NO VMB-06
MANYETİK TABANLI ESNEK KOL



SİPARİŞ NO. VMB-11
BÜYÜK BOY MANYETİK TABAN
M8x1.25p, 140Kg

DETAYLAR

KOD	TABAN ÖLÇÜLERİ BxExY	TUTMA GÜCÜ	ANA KOL O.DxL	AĞIRLIK (Kg)	FİYAT USD
VMB-06	60x50x55	80 Kg	Ø16x208	1.6	
VMB-00	60x50x55	80 Kg	----	1.1	
VMB-11	117x50x55	140 Kg	----	2.1	
VMB-12	60x50x55	80 Kg	----	1.1	
VML-M	60x50x55	80 Kg	Ø15x325	1.7	

HALOJEN TEZGAH LAMBASI

- GÖZÜ RAHATSIZ ETMEYEN SARI IŞIK
- EKLEMLİ KOLU SAYESİNDE TİTREŞİME DİRENÇLİ PERFORMANS SAĞLAR
- YÜKSEK KALİTELİ ELEKTRİK AKSAM KULLANILMIŞTIR
- TEZGAHA KOLAYLIKLA OTURUR ve ÇOK YER KAPLAMAZ
- ÇİFT TABAKALI DIŞ KAPLAMA ENERJİ KAYBININ ÖNÜNE GEÇER

DETAYLAR

KOD	GİRİŞ VOLTAJİ	LAMBA	AĞIRLIK (Kg)	FİYAT USD
VHL-20F	110V - 220V	12V	1,1	

MANYETİK AYAKLAR

SABİT KOL TİPİ VMB-B, 01, 02, 03
SAAT SABİTLEME DELİK ÇAPLARI Ø6.5 & Ø8



SİPARİŞ NO. VMB-B
MANYETİK AYAK /80Kg



SİPARİŞ NO VMB-01
MANYETİK AYAK
AYARLANABİLİR TİP /80Kg



SİPARİŞ NO VMB-02
MANYETİK AYAK
AYARLANABİLİR TİP 80Kg



SİPARİŞ NO. VMB-03
MANYETİK AYAK
UZUN ÇUBUK TİPİ / 130Kg

Ø12x171

Ø20x310



BÜYÜK ÇAP &
UZUN ÇUBUK

DETAYLAR

KOD	AYAK ÖLÇÜLERİ BxExY	TUTMA GÜCÜ	SABİT KOL ÇAPxBOY	HAREKETLİ KOL ÇAPxBOY	AĞIRLIK (Kg)	FİYAT USD
VMB-B	60x50x55	80 Kg	Ø12x173	Ø10x162	1.6	
VMB-01	60x50x55	80 Kg	Ø12x176	Ø10x150	1.6	
VMB-02	60x50x55	80 Kg	Ø12x171	Ø10x153	1.6	
VMB-03	115x50x55	130 Kg	Ø20x310	Ø14x200	3.9	
VMB-70	73x50x55	100 Kg	Ø25x128	Ø25x116	1.7	
VMB-106	73x50x55	100 Kg	Ø25x125	Ø25x125	1.9	
VMB-106H	75x50x55	100 Kg	Ø25x125	Ø25x125	2.2	

UNIVERSAL MANYETİK AYAK

VMB-70,106,106H SAAT SABİTLEME DELİK ÇAPLARI Ø6.5, Ø8 & GEÇME



SİPARİŞ NO. VMB-70
DELUXS UNIVERSAL
MANYETİK AYAK
/100Kg



SİPARİŞ NO. VMB-106
MEKANİK KOLLU
MANYETİK AYAK /100Kg



SİPARİŞ NO. VMB-106H
HİDROLİK KOLLU
MANYETİK AYAK /100Kg



Ø8

Ø6.5

MANYETİK TABANLI ÜRÜNLER



SİPARİŞ NO. VMF-112
MİNİ MANYETİK AYAK



SİPARİŞ NO. VH-70
MİNİ MANYETİK AYAK

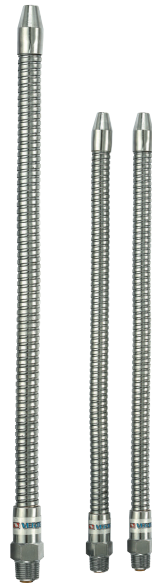

SİPARİŞ NO. VMH-63
MANYETİK AYAKLI
METAL SULAMA
HORTUMU (1 HORTUM)



SİPARİŞ NO. VMS-1/4
SİPARİŞ NO. VMS-3/8
SULAMA HORTUMU

DETAYLAR

KOD	AYAK ÖLÇÜLERİ LxWxH	TUTMA GÜCÜ	SABİT KOL ÇAPxBOY	HAREKETLİ KOL ÇAPxBOY	AĞIRLIK (Kg)	FİYAT USD
VMF-112	34,5x30x35	30 Kg	Ø20x70	Ø20x65	0.6	
VH-70	31x31x32	15 Kg	Ø10x70	Ø6x90	0.4	
VMS-1/4	----	----	Ø11x320	HORTUM DIŞI 1/4	0.2	
VMS-3/8	----	----	Ø15x370	HORTUM DIŞI 3/8	0.4	
VMH-54	60x50x55	80 Kg	Ø16x330	2 ADET HORTUM	1.4	
VMH-62	60x50x55	80 Kg	Ø16x330	3 ADET HORTUM	1.5	
VMH-63	60x50x55	80 Kg	Ø11x330	1 ADET HORTUM	1.6	
VMH-64	60x50x55	80 Kg	Ø11x330	2 ADET HORTUM	2	
VMH-65	60x50x55	80 Kg	Ø11x330	3 ADET HORTUM	2.2	



SİPARİŞ NO. VMH-54
MANYETİK AYAKLI
PLASTİK SULAMA
HORTUMU (2 HORTUM)



SİPARİŞ NO. VMH-62
MANYETİK AYAKLI
PLASTİK SULAMA
HORTUMU (3 HORTUM)



SİPARİŞ NO. VMH-64
MANYETİK AYAKLI
METAL SULAMA
HORTUMU (2 HORTUM)



SİPARİŞ NO. VMH-65
MANYETİK AYAKLI
METAL SULAMA
HORTUMU (3 HORTUM)

ELEKTROMANYETİK TABLALAR İÇİN KONTROL ÜNİTESİ

KOD: VCC-705 (5A)

VGI-618~2048 / VLZ-510~612 / VIW-612~1224 / VEM-1530A~50100A İÇİN

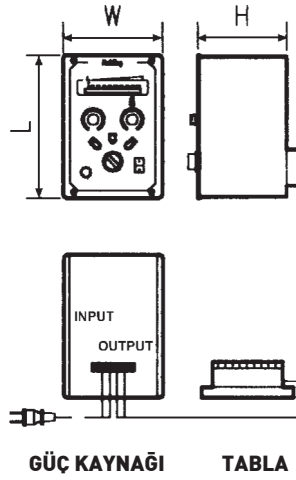

ÖZELLİKLER

- STANDART TİP ELEKTROMANYETİK TABLALAR İÇİNDİR.
- 5A KAPASİTESİ İLE MANYETİK GİDERME SÜRESİ 6-15 SANİYEDİR.
- LED VOLTAJ GÖSTERGESİ İLE ELEKTROMANYETİK TABLANIN GÜCÜNÜ HASSAS BİÇİMDE AYARLAR.

KOD: VCC-805A (10A)

VGI-2060 / VEA-816~1640 / VEM-2040Z~40100Z İÇİN
VCC-815 (15A) İÇİN VEA-2040~VEA2460 / VLZ-2060 / VEM-50100A / VEM-50100Z İÇİN

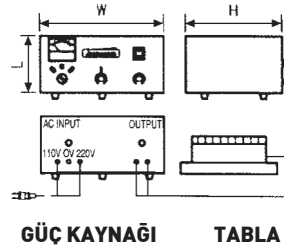

ÖZELLİKLER

- STANDART TİP ELEKTROMANYETİK TABLALAR İÇİNDİR.
- 10A ve 15A KAPASİTESİ İLE MANYETİK GİDERME SÜRESİ 6-15 SANİYEDİR.
- LED VOLTAJ GÖSTERGESİ İLE ELEKTROMANYETİK TABLANIN GÜCÜNÜ HASSAS BİÇİMDE AYARLAR.

KOD: VCC-820 (20A)

VEA-2460~/ VEM-60100Z İÇİN

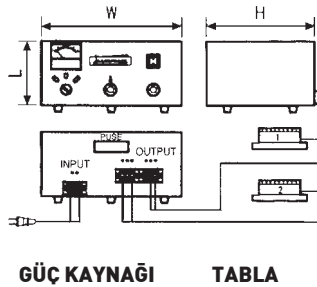

ÖZELLİKLER

- ÇOK KUVVETLİ BÜYÜK ELEKTROMANYETİK TABLALARDA KULLANILIR ve AYNI ANDA İKİ TABLAYI KONTROL EDEBİLİR.
- 20 A KAPASİTESİ İLE MANYETİK GİDERME SÜRESİ 8-15 SANİYEDİR.
- LED VOLTAJ GÖSTERGESİ İLE ELEKTROMANYETİK TABLANIN GÜCÜNÜ HASSAS BİÇİMDE AYARLAR.
- DAHİLİ FANI SOĞUTMA SAĞLAR

DETAYLAR

KOD	GİRİŞ VOLTAJI TEK FAZ	ÇIKIŞ		ÖLÇÜLER			NET AĞIRLIK (Kg)	FİYAT USD
		VOLTAJ	AKIM	EN	BOY	YÜKSEKLİK		
VCC-705	AC 110V/220V	DC 0-100V	5A	200	137	122	3.5	
VCC-805A	AC 110/220/380/415/440V	DC 0-100V	10A	150	330	260	18	
VCC-815	AC 220/380/415/440V	DC 0-120V	15A	150	330	260	20	
VCC-820	AC 220/380/415/440V	DC 0-120V	20A	180	385	295	32	

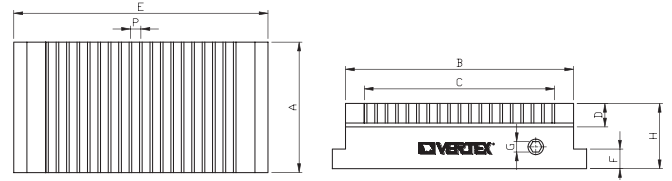
MANYETİK TABLA
18 KGF

ÖZEL OLARAK İŞLENMİŞ HASSAS YÜZEY
DETAYLAR

KOD	ÖLÇÜLER	TABLA ÖLÇÜLERİ				KUTUP HATVESİ	TABLA SABİTLEME YÜZEYİ			YÜKSEKLİK	AĞIRLIK (Kg)	FİYAT USD
		A	B	C	D		P	G	E			
VG-407	100x175	100	175	146	20	8(2+6)	8	187	15	50	7.2	
VG-510	125x250	125	250	206	20	8(2+6)	8	262	15	50	15	
VG-612	150x300	150	300	256	20	8(2+6)	8	318	15	50	18.5	
VG-614	150x350	150	350	306	20	8(2+6)	8	368	15	50	20.9	
VG-618	150x450	150	450	406	20	8(2+6)	8	468	15	50	27.5	
VG-816	200x400	200	400	365	20	8(2+6)	8	418	15	50	32	
VG-818	200x450	200	450	406	20	8(2+6)	8	468	15	50	36.3	
VG-820	200x500	200	500	456	20	8(2+6)	8	518	15	50	40.4	
VG-1020	250x500	250	500	456	20	8(2+6)	8	518	15	50	50.3	
VG-606	150x150	150	150	116	20	8(2+6)	8	162	15	50	9	
VG-1224	300x600	300	600	550	18	8(2+6)	8	620	15	48	73.5	

İNCE ÇİZGİLİ MANYETİK TABLA
19 KGF

UYGULAMA

BU YENİ İNCE TİP TABLA, 50mm YÜKSEKLİK , TAŞLAMA İŞLEMLERİNE, İNCE SAÇLARA VE KÜÇÜK İŞ PARÇALARINA UYGUNDUR. GENİŞ BİR UYGULAMA ALANI VARDIR ve TABLA ÜZERİNDE GENİŞ BİR MANYETİK ALAN OLUŞTURUR.

ÖZELLİKLER

- İNCE ve HAFİF OLMASI ÇOK YÖNLÜ KULLANIM SAĞLAR
- SIK KUTUPLU OLMASI, BU MODELDE, TABLAYI İNCE ve KÜÇÜK PARÇALAR İÇİN UYGUN KILAR
- TABLA YÜZEYİ BENZER TİPLERE GÖRE DAHA GENİŞ MANYETİKLEŞMİŞ ALAN SAĞLAR

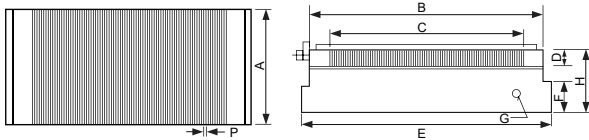
DETAYLAR

KOD	ÖLÇÜLER	TABLA ÖLÇÜLERİ				KUTUP HATVESİ	TABLA SABİTLEME YÜZEYİ			YÜKSEKLİK	G	AĞIRLIK (Kg)	FİYAT USD
		A	B	C	D		P	A	E				
VG-1018B	100x175	100	175	146	18	5(1+4)	100	195	15	50	8	7.7	
VG-1515B	150x150	150	150	116	18	5(1+4)	150	175	15	50	8	10	
VG-1530B	150x300	150	300	256	18	5(1+4)	150	320	15	50	8	18.8	
VG-1535B	150x350	150	350	306	18	5(1+4)	150	370	15	50	8	21.6	
VG-1545B	150x450	150	450	406	18	5(1+4)	150	470	15	50	8	27.4	
VG-2040B	200x400	200	400	356	18	5(1+4)	200	420	15	50	8	32.3	
VG-2045B	200x450	200	450	406	18	5(1+4)	200	470	15	50	8	36.3	

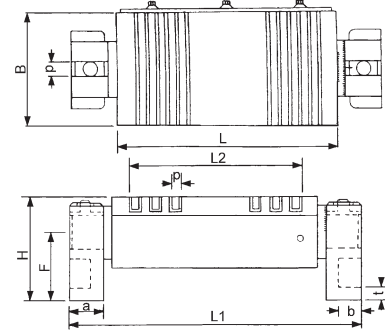
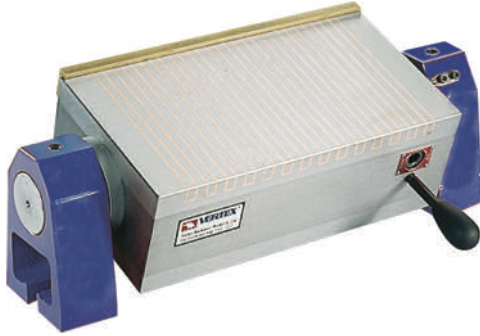
DÖNER MANYETİK TABLA
18 KGF

(0°-90°) AÇILI PARÇALARIN TAŞLANMASINI SAĞLAR. ÖLÇÜ GÖSTERGESİ SAYESİNDE KOLAYCA AYARLANIR
DETAYLAR

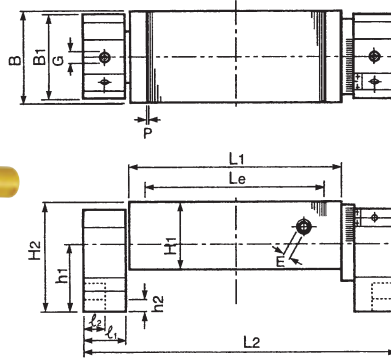
KOD	ÖLÇÜLER	TABLA ÖLÇÜLERİ			KUTUP HATVESİ	AYAK ÖLÇÜLERİ						YÜKSEKLİK H	AĞIRLIK (Kg)	FİYAT USD
		B	L	L2	P	a	b	t	F	L1	d			
VLU-510B	125x250	125	250	191	8,5 (2.5+6)	50	35	17	96	380	16	150	33.2	
VLU-612B	150x300	150	300	245	8,5 (2.5+6)	50	35	17	96	430	16	150	44.5	
VLU-618B	150x450	150	450	414	8(2+6)	50	27	15	90	565	-	145	43	

İNCE ÇİZGİLİ DÖNER MANYETİK TABLA
17 KGF

UYGULAMA

(0°-90°) ARALIĞINDAKİ TAŞLAMALARA UYGUNDUR.

ÖZELLİKLER

- ÖLÇEKLENDİRİLMİŞ DÖNER SAFTI HERHANGİ BİR AÇIDA ÇALIŞMASINI SAĞLAR
- AÇMA KAPAMA SIRASINDA YÜZEY HASSASİYETİ DEĞİŞMEZ.
- SIK KUTUPLU YAPISI İNCE ve KÜÇÜK PARÇALARIN TAŞLANMASINA İMKAN SAĞLAR.

DETAYLAR

KOD	ÖLÇÜLER	TABLA ÖLÇÜLERİ				KUTUP HATVESİ	UZUNLUK L2	AYAK ÖLÇÜLERİ						YÜKSEKLİK H2	AĞIRLIK (Kg)	FİYAT USD
		B	L1	L2	H1	P		B	e1	e2	G	h1	h2			
VLU-407BF	100x175	100	175	125	78	2 (1+1.5)	293	100	50	25	16	103	50	145	19	
VLU-510BF	125x250	125	250	200	78	2 (1+1.5)	368	100	50	25	16	103	50	145	27	
VLU-612BF	150x300	150	300	246	78	2 (1+1.5)	418	100	50	25	16	103	50	145	31	
VLU-614BF	150x350	150	350	296	78	2 (1+1.5)	468	100	50	25	16	103	50	145	37	
VLU-618BF	150x450	150	450	396	78	2 (1+1.5)	568	100	50	25	16	103	50	145	43	

MANYETİK SİNÜS TABLA İKİ YÖNLÜ

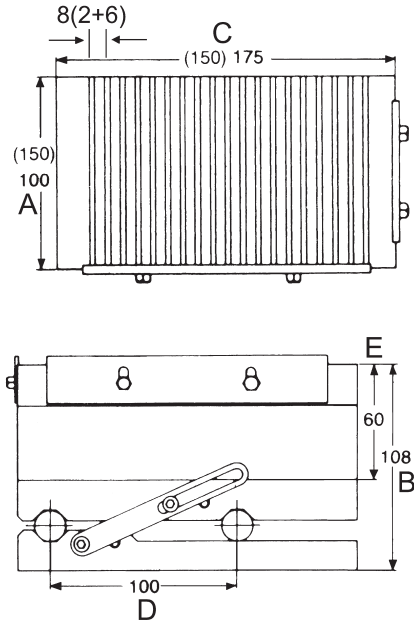

DETAYLAR

KOD	A	B	C	D	E	P	AÇI	AĞIRLIK (Kg)	ÖZELLİK	FİYAT USD
V-612M	150	108	300	100	60	8(2+6)	0°~45°	27	İKİ YÖNLÜ	

AÇILI MANYETİK SİNÜS TABLA



ÖZELLİKLER

- ÇİFT YÖNLÜ SİNÜS TABLA, AYNI ANDA İKİ FARKLI AÇIDA TAŞLAMA YAPILABİLİR.
- SERTLEŞTİRİLMİŞ ÇELİK ALAŞIMDAN OLUSUR
- KESİN AÇI ÖLÇÜ BLOĞUNDAN ELDE EDİLİR.
- HİÇ BİR SAPMA OLMADAN HERHANGİ BİR AÇIDA POZİTİF KİLİTLEME YAPILABİLİR.
- POZİTİF KİLİTLEME SİSTEMİ YÜZEYE MONTELİDİR.

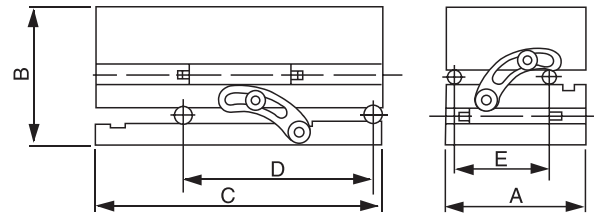

DETAYLAR

KOD	A	B	C	D	E	P	AÇI	AĞIRLIK (Kg)	ÖZELLİK	FİYAT USD
V-612MS	150	142	300	200	100	1+3	0°~60°	34,7	AÇILI	

MİNİ TİP MANYETİK TABLA (SADECE KARBÜR MALZEMELER İÇİN)

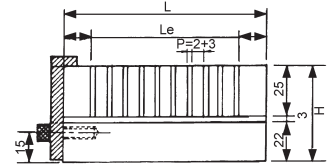
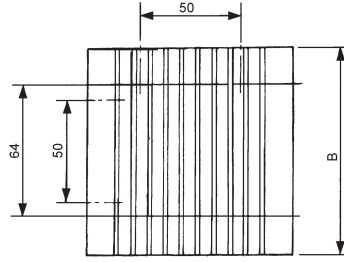
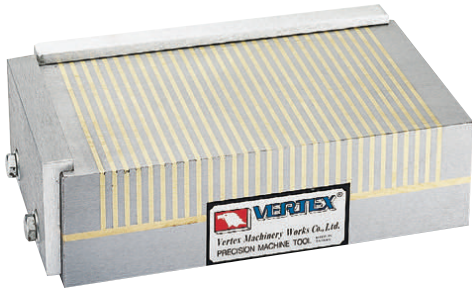

ON/OFF DÜĞMESİ YOKTUR

- BU MANYETİK TABLA ZAYIF MANYETİK MALZEMELER İÇİN DİZAYN EDİLMİŞTİR.
- GENİŞ MANYETİK BİR TABLA ÜZERİNE MONTE EDİLEBİLİR.
- SADECE KARBÜR MALZEMELERDE İŞLEM YAPMAK İÇİN KULLANILIR.

DETAYLAR

KOD	BOYUT	TABLA ÖLÇÜSÜ			KUTUP HATVESİ	YÜKSEKLİK	TEST BLOĞU	AĞIRLIK (Kg)	FİYAT USD
		B	L	Le					
VG-407H	100x180	100	180	152	5(2+3)	50	α 50x25t TEST BLOĞU(TUNGSTEN)	7	
VG-410H	100x250	100	250	222	5(2+3)	50	210N(21Kg)	10	

MANYETİK AYIRICI

VMS-9B

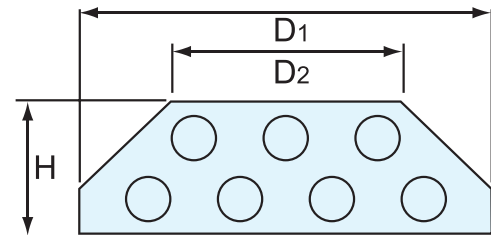

VMS-7B



- MANYETİK AYIRICI BAR ÜNİTESİ KUVVETLİ MIKNATİSTAN İMAL EDİLMİŞTİR.
- TEMEL KULLANIM AMACI; KİMYA, PLASTİK ve ÇEŞİTLİ ALANLARDA TOZ ve KÜÇÜK TANELİ HAMMADDE İÇERİR.
- İÇİNDEKİ METAL ARTIKLARI AYIRMAK ÜRETİM VERİMLİLİĞİ SAĞLAMAKTADIR
- KOLAY MONTAJ SAYESİNDE BİRÇOK ALANDA KULLANILIR.
- SICAKLIK LİMİTİ 60 C°

DETAYLAR

KOD	D1	D2	H	TÜP ÖLÇÜLERİ	AĞIRLIK (Kg)	FİYAT USD
VMS-7B	175	112	75	Ø22,2x180	2.4	
VMS-9B	218	156	75	Ø22,2x230	3.8	

MİNİ EL TİPİ MANYETİK TALAŞ TOPLAYICI



- TUTTUĞU PARÇALARIN DÜŞMESİ İÇİN TETİĞİ ÇEKİNİZ
- KALICI MIKNATIS
- DARBEYE DAYANIKLI PLASTİK MALZEME
- HAFİF ve KULLANIŞLI TASARIM
- EV, OFİS ve FABRİKA İÇİN KÜÇÜK DEMİR VEYA ÇELİK PARÇALARI TOPLAR

DETAYLAR

KOD	BOY	EN	YÜKSEKLİK	TUTMA KÜTLESİ	AĞIRLIK (Kg)	FİYAT USD
VCC-16	110	110	190	0,65	0,7	

AYARLANABİLİR KOLLU MANYETİK TALAŞ TOPLAYICI



- DAR ALANDA MÜKEMMEL ÇALIŞMA
- ÇİVİ, CIVATA, KAĞIT KELEPÇESİ GİBİ DEMİR İÇEREN METAL ÜRÜNLER TOPLAR
- RAHAT KAVRAMA
- KULLANIMI KOLAY, GÜVENİLİR, PRATİK ve HIZLI
- KALICI MIKNATIS

DETAYLAR

KOD	MANYETİK AYAK	TOPLAM BOY	TUTMA KÜTLESİ	AĞIRLIK (Kg)	FİYAT USD
VCC-17A	120 x 70	700	0,7	2	

TEKERLEKLİ MANYETİK TALAŞ TOPLAYICI

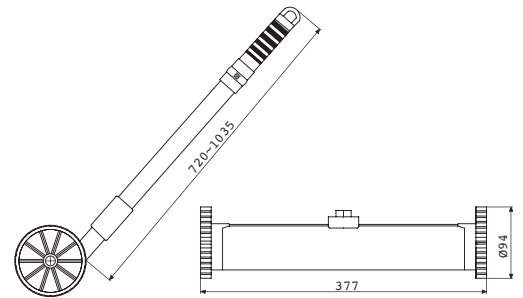

- HİÇBİR PROBLEM ÇIKARMADAN MANYETİK ATIKLARI TEKER TEKER TOPLAR
- KULLANIMI KOLAY, GÜVENİLİR, PRATİK ve HIZLI
- DÜĞMESİNE BASARAK MANYETİK KUVVETİ ÇALIŞTIRABİLİRSİNİZ
- KALICI MIKNATIS

DETAYLAR

KOD	TOPLAM BOY	TOPLAM GENİŞLİK	TUTMA KÜTLESİ	AĞIRLIK (Kg)	FİYAT USD
VCC-19	720 ~ 1035	377	0,85	1,5	

MANYETİK ALMA CİHAZI

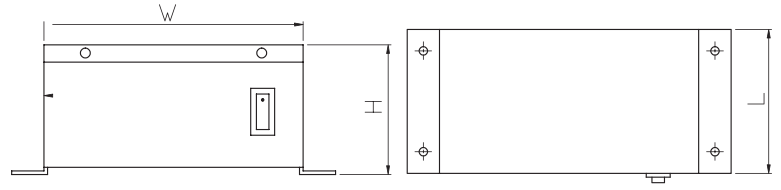
VDM-8, 11

- GİRİŞ VOLTAJI 110-220 VAC'DİR
- AÇMA KAPAMA DÜĞMESİ MEVCUTTUR
- TAKIMLARIN, MATKAPLARIN KOLAYCA MANYETİĞİNİ ALIR

DETAYLAR

KOD	GİRİŞ VOLTAJI	KAPASİTE	ÇALIŞMA YÜZEYİ	YÜKSEKLİK	ÇEVİRİM ORANI	AĞIRLIK (Kg)	FİYAT USD
VDM-8	AC-	110V	210VA	160x110	100	50%	4.5
VDM-11		220V	550VA	200x280	130	100%	16

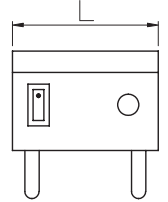
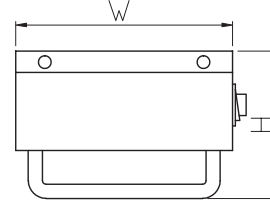
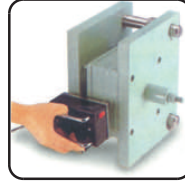
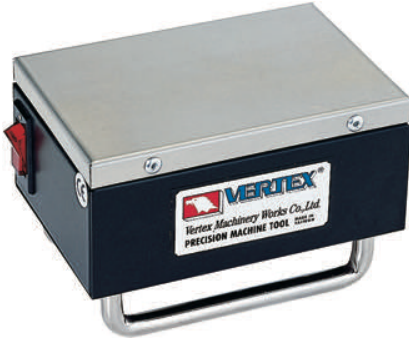
MİNİ TİP MANYETİK ALMA CİHAZI
PORTATİF KULLANIM

DETAYLAR

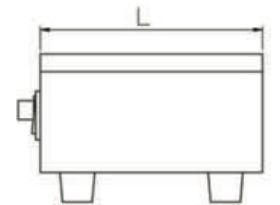
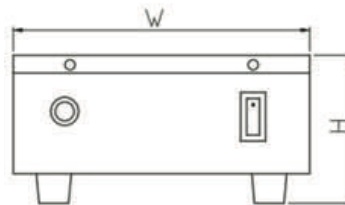
KOD	GİRİŞ VOLTAJI	KAPASİTE	ÇALIŞMA YÜZEYİ	YÜKSEKLİK	ÇEVİRİM ORANI	AĞIRLIK (Kg)	FİYAT USD
VDM-9	AC-	110V	110VA	123x83	83	90%	1,8
		220V					

LÜKS TİP MANYETİK ALMA CİHAZI

DETAYLAR

KOD	GİRİŞ VOLTAJI	KAPASİTE	BOYUT			ÇEVİRİM ORANI	AĞIRLIK (Kg)	FİYAT USD
			L	W	H			
VDM-68	AC-	110V	140	195	110	100 %	7,4	
		220V						AC-330VA

ÇOK AMAÇLI AÇI ÖLÇER



- HİDROLİK YAĞ İLE YÖNLENDİRİLEN İŞARETLEYİCİ İLE YÜKSEK STABİLİTE, HASSAS ve HATALARI ELİMİNE EDEN ÖLÇÜM, 1 DERECE ALTI İÇİN ÖLÇEKLENDİRME
- ÇİFT DAİRESEL ÖLÇEKLENDİRME, OKUMA HATALARINDAN KAYNAKLANAN SORUNLARI ENGELLER.
- TRANSPARAN SICAKLIK ÖNLEYİCİ YAĞ, DAHA İYİ BİR OKUMA SAĞLAR.
- DEMİR İÇEREN MALZEMELERİN YÜZEYLERİNDE, YUVARLAK BİR BORU ve ÇİFT RAYLI MIKNATIS SİTEMİ İLE AÇI SEVİYESİ ARTIRILABİLİR.
- İNCE DEMİR PLAKASI, GENİŞ ÖLÇÜM ARALIKLARINDA AÇI SEVİYESİ ALTINDA ÇEKEBİLİR.
- TEZGAHLAR İÇİN UYGUNDUR.
- TAŞLAMA MAKİNELERİ
- DIŞ ve İÇ KONİK AÇILAR
- YATAY OLMAYAN BİR DÜZLEMDE DURAN AÇI BLOKLARI ÜZERİNDE ÇEŞİTLİ POZİSYONLARDA UYGULAMA GÖSTERİMİ
- SAĞ AÇI TABLASI
- GERİLİME DİRENÇLİ DÖKME DEMİRDEN YAPILMIŞTIR.
- KARE ve PARALEL DIŞ YÜZEYLERİ İLE ZEMİNE TAM OTURUR ve 0,01mm 100mm ARALIĞINDADIR.

DETAYLAR

KOD	UZUNLUK	GENİŞLİK	YÜKSEKLİK	TABAN	HASSASİYET	BOY	FİYAT USD
VAL-10	78	62	14	PLASTİK	0,2°	150	
VAL-30	93	79	15	PLASTİK	0,1°	150	
VAL-50	93	79	16	METAL	0,083°	-	
VAL-60	140	130	20	METAL	0,05°	-	
VAL-20	70	65	30	PLASTİK	0,2°	3.000	

KISKAÇLI V YATAK

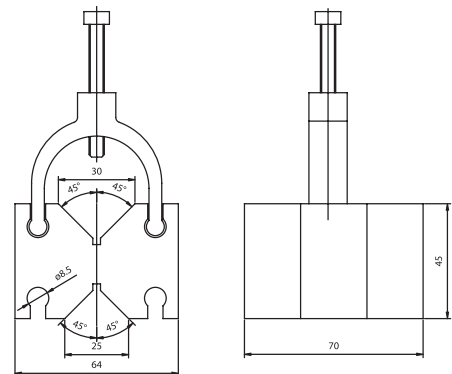
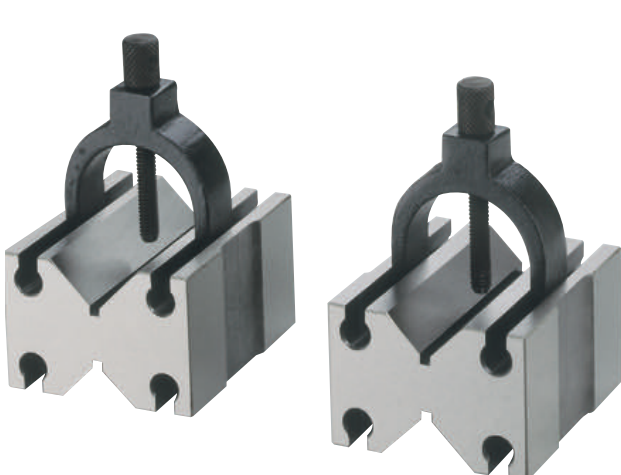

DETAYLAR

KOD	AĞIRLIK (Kg)	FİYAT USD
VBC-006	2,6	

ZIMBA FORM VERME MAKİNASI

- ZIMBA FORM VERME MAKİNESİ TEZGAH ÜZERİNE SABİTLENEREK 1,5mm'den 25mm'e KADAR ZİMBALARA FORM VERMEK İÇİN KULLANILIR.
- 3 ADET DÖNEN DİSK SAYESİNDE KOLAY MERKEZLEME.
- DİSKLERİN HASSASİYETİ SAĞA YADA SOLA DÖNERKEN 0,005mm İÇERİSİNDEDİR.
- 5mm ile 35mm UZUNLUĞU OLAN ZİMBALAR İÇİN UYGUNDUR.
- A NOKTASINDAKİ SALGI 0,005mm'DİR.
- B NOKTASINDAKİ SALGI 0,008mm'DİR.

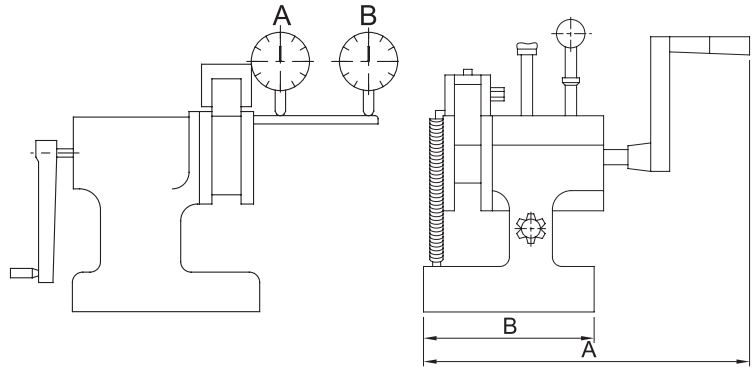
DETAYLAR

KOD	A	B	AĞIRLIK (Kg)	FİYAT USD
V-PG	172	90	6,6	

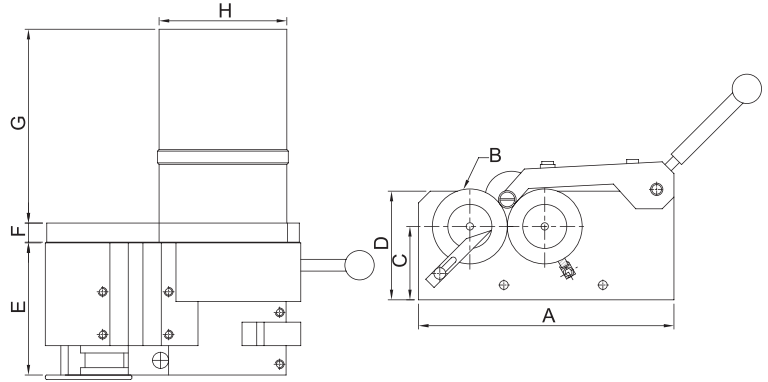
MOTORLU ZIMBA FORM VERME MAKİNASI

- YÜKSEK HASSASİYETLİ SİLİNDİRİK TAŞLAMA SAĞLAR.
- MERKEZLEMEYE İHTİYAÇ DUYMADAN DİREKT İŞLENECEK MALZEME SİLİNDİR ÜZERİNE YERLEŞTİRİLEREK ÇALIŞMAYA HAZIR HALE GELİR.
- TEK ELLE KULLANIMA UYGUN OLUP KURULUMU KOLAYDIR.
- OTOMATİK SÜRÜLEN SİLİNDİRLERİ SEBEBİYLE, BÜTÜN KONSANTRE ÇALIŞMA ALANINA VERİLEBİLİR.

- SİVRİLEŞTİRMEYE UYGUN FORMDADIR
- ÇİFT SİLİNDİR ÜNİTESİ UZUN PİM MALZEME İÇİN UYGUNDUR.
- 50Hz/220V : 108 rpm
- SİLİNDİR HIZI 60Hz/110V : 129 rpm
- HASSASİYET (YUVARLAK ve EŞMERKEZLİLİK) : 25,4 mm
- SİLİNDİR SÜRME MOTORU 110V, TEK EVRE, 25W (ÖZELLİKLER, KULLANIM ŞARTLARINA GÖRE DEĞİŞKENLİK GÖSTERE BİLİR)

DETAYLAR

KOD	A	B	C	D	E	F	G	H	AĞIRLIK (Kg)	FİYAT USD
V-PGM	174	Ø51	50	74	90	13	132	87	11,8	

TABLA HAREKET MOTORU

Boyuna X Eksenine İin



Enine Y Eksenine İin



Dikey Z Eksenine İin

- TABLA İLERLEME CİHAZI OLMAYAN TM FREZELER İİN UYGUNDUR.
- KOLAY KURULUM.
- OTOMATİK KAPANMA.
- STN TERMAL ZELLİK.
- YUMUŐAK ve PRZSZ OPERASYON.
- GVENLİ ve SORUNSUZ PERFORMANS.
- YKSEK G.
- YENİ, GL, ST KALİTE ve UZUN MR SAĐLAYACAK DİZAYN.
- YALNIZCA 110V İLE KULLANILIR.

DETAYLAR

KOD	VOLTAJ	HIZ ARALIĐI	MAX. HIZ	MAX. TORK	LxWxH	AĐIRLIK (Kg)	FİYAT USD
VPF-500X	110V	4-160 rpm	200 rpm	650 in/lb	290x200x320	6,3	
VPF-500Y						6,7	
VPF-500Z						6,9	

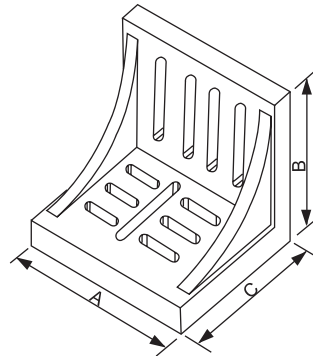
GNYE PLEYTİ

- GERİLİME DİRENLİ DKME DEMİRDEN YAPILMIŐTIR.
- KARE ve PARALEL DİŐ YZEYLERİ İLE ZEMİNE TAM OTURUR ve 0,01mm/100mm ARALIĐINDADIR.

DETAYLAR

KOD	A	B	C	AĐIRLIK (Kg)	FİYAT USD
VR-6	150	126	115	3,8	
VR-8	202	150	126	7,4	
VR-10	250	202	126	12,1	
VR-12	300	228	202	23,7	

PAH KIRMA MAKİNASI

VCF-500

AKSESUAR : KESİCİ FREZE UCU SPUN422
UÇ : SPKN 1203

KOD	FİYAT USD
VCF-500	
VCF-500W	
VCF-500F	

PRATİK

- A. UNİVERSAL UYGULAMA
- B. BASİT KULLANIM
- C. HIZLI, HASSAS, VERİMLİ
- D. ZAMAN KAZANDIRIR

VCF-500W

AKSESUAR : ÇANAK TAŞ 100Øx50x17Ø

VCF SERİSİ ÖZELLİKLERİ

- KOLAY KULLANIM, VASIFISIZ ELEMANLARA UYGUN
- ÇELİK, DÖKME DEMİR, DEMİR DIŞI METALLER, PLASTİK, AKRİLİK VS MALZEMELERİN HER BOYU İŞLENEBİLİR

500 : DEĞİŞTİRİLEBİLİR KARBÜR UÇLAR ve BIÇAK MALİYETİNİ DÜŞÜRÜP, ÜRETİM KAPASİTESİNİ ARTIRIR.

500W : ÇANAK TAŞ YA DA FLANŞ SAYESİNDE SICAK İŞLENMİŞ PARÇALARA PAH KIRMA İŞLEMİ GERÇEKLEŞTİRİLEBİLİR.

500F : YÜZEY FREZELEME PRENSİBİNE GÖRE ÇALIŞIR. PAH KIRMA İŞLEMİ YÜZEYİ, FREZELEME MAKİNASI İLE AYNIDIR.

VCF-500F

AKSESUAR : KESİCİ FREZE UCU
UÇ : SEKN 1203

TEKNİK BİLGİ

GEREKLİ ALAN	500	500W	500F
	500x320mm	500x440mm	500x220mm
AĞIRLIK (Kg)	28.5	29.1	29
VOLTAJ	3Ø 220V ve 1Ø 110V/220V 50HZ/60HZ 3Ø 380V/415V		
MOTOR ÇIKIŞI	0.7KW		
HIZ	3500 r.p.m		
RAY YUVASI UZUNLUĞU	500mm	500 mm	500 mm
PAH YÜKSEKLİĞİ	0-3 mm		
PAH AÇISI	15°~45° (AYARLANABİLİR)	45°	45°

PAH KIRMA MAKİNASI

VCF-500S

AKSESUAR : FLAP DİSK 165Øx22Ø

KOD	FİYAT USD
VCF-500S	
VCF-600	
VCF-700	

PRATİK

- A. FLAP DİSK KULLANILIR
- B. ÇELİK ve SERTLEŞTİRİLMİŞ DÖKME DEMİR İÇİN UYGUNDUR
- C. YUMUŞAK DEMİR ve ALUMİNYUM İÇİN UYGUN DEĞİLDİR.
- D. DÜZENSİZ PARÇALARDA KULLANILIRSA OLUŞAN YÜZEY GÜÇSÜZ OLABİLİR

VCF-600

AKSESUAR : UÇ SPMW 321 SPMW 090308

VCF ÖZELLİKLERİ

- 500S : FLAP DİSK KULLANILIR
SERT ve RİJİT MALZEMELERDE UYGUNDUR
- 600 : KOLAYCA TAŞINIR ve AĞIR PARÇALARIN
İŞLENMESİNİ KOLAYLAŞTIRIR
- 700 : TAŞINABİLİRDİR. DEMİR ve DEMİR ALAŞIMLARI ÖZELLİKLE ÇELİK VE
DÖKME DEMİR İÇİN UYGUNDUR

KARE ŞEKLİ TUNGSTEN KARBÜR UÇ OLAN ISO1203SPUN KULLANILIR. BASİTLEŞTİRİLMİŞ KULLANIMI VASİFSİZ ELEMANLAR İÇİN UYGUNDUR

VCF-700

AKSESUAR : FREZE

TEKNİK BİLGİ

	VCF-500S	VCF-600	VCF-700
GEREKLİ ALAN	330x410 mm	500x440 mm	500x220 mm
AĞIRLIK (Kg)	26	3.7	14
VOLTAJ	3Ø220V ve 1Ø110V/220V 3Ø380V/415V 50HZ/60HZ		
MOTOR ÇIKIŞI	0.7KW		0.37KW
HIZ	3500 r.p.m	12000 r.p.m	3500 r.p.m
RAY YUVASI UZUNLUĞU	320 mm	100 mm	200 mm
PAH YÜKSEKLİĞİ	0-3 mm	0-3 mm	0-7 mm
PAH AÇISI	45°	45°	15° ~ 45° AYARLANABİLİR

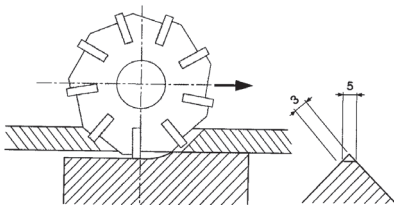

UNIVERSAL BİLEME MAKİNASI

KOD	FİYAT USD
U2	

STANDART AKSESUARLAR

TAŞ DÜZELTME ELMASI	1 PARÇA
TAŞ FLANŞI (BAĞLI)	1 PARÇA
ÇANAK TAŞ	1 PARÇA (U2-G)
PENS Ø4,6,8,10,12 mm	5 PARÇA
MERKEZLEME ÇUBUĞU	1 PARÇA
TAHRİK KAYIŞI	1 PARÇA
KİLİTLEME PİMİ	1 PARÇA
ALETLER	1 SET

OPSİYONEL AKSESUARLAR

MATKAP BİLEME APARATI U2-T
 FREZE BİLEME APARATI U2-E
 TAKIM TAŞLAMA APARATI U2-L
 ÇANAK TAŞ BALANS STANDI
 LBS-100
 ELMAS ÇANAK TAŞ U2-D
 SUNİ REÇİNELİ ve CBN ÇANAK TAŞ U2-R
 EXTRA PENSLER 1, 2, 2.5, 3, 5, 7, 9, 16, 18, 20, 25mm
 VE 1/8", 3/16", 1/4", 5/16", 3/8", 1/2", 5/8").

■ L:120 ■ D:28 ■ d:20 ■ G:2.0P ■ HASSASİYET: ±0.02MM

■ α:17°30' ■ AĞIRLIK:0.18KGS ■ SERTLİK: HRC47°

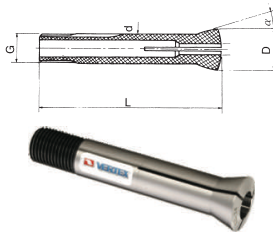

KOD	ÖLÇÜ	FİYAT USD
NO : 1	Ø3~16 mm	



KOD	ÖLÇÜ	FİYAT USD
NO : 2	Ø18~25 mm	

- HSS ve KARBÜR'DEN ÜRETİLMİŞ NEGATİF AÇILI , RAYDUSLU DAHİL ÇOK ÇEŞİTLİ KESİCİ UÇLARIN TAŞLANMASINDA KULLANILIR.
- POZİSYONLU UNIVERSAL İNDEKS KAFASI İLE HERHANGİ BİR AÇI ve ŞEKLİN TAŞLANMASINI SAĞLAR.
- FREZE, MATKAP, KALEM VS TAŞLANABİLMESİ İÇİN 100-3600 DEVİR ARASI ÇALIŞTIRILABİLİR.
- ÖZEL APARATLARIN KURULUMU ve KULLANIMI OLDUKÇA BASİTTİR.

MAX. TAŞLAMA ÇAPI Ø25

TEPE AÇISI 0°-180°

KANAL AÇISI 0°- 45°

NEGATİF AÇI 0°-26°

TAŞLAMA MİLİ 3600 RPM

ÇANAK TAŞ 100x50x20 mm

MOTOR 1/3 HP 220V50/90HZ

NET AĞIRLIK 45 Kg

BRÜT AĞIRLIK 58 Kg

MAKİNA ÖLÇÜLERİ BxExY 45x40x35 cm

KUTU ÖLÇÜLERİ BxExY 55x45x47 cm

KOD	FİYAT USD
U2-E	
U2-T	
U2-L	
U2-D #100	
U2-B KAYIŞ	
U2-G ÇANAK TAŞ	
U2-R #200	

U2-E FREZE BİLEME APARATI	U2-T MATKAP BİLEME APARATI
AĞIRLIK : 2Kg	AĞIRLIK : 0.9Kg
U2-L TORNA TAKIM TAŞLAMA APARATI	ELMAS ÇANAK TAŞ SUNİ REÇİNELİ & CBN ÇANAK TAŞ
	<div style="display: flex; justify-content: space-around;"> <div> <p>U2-D</p> <p>AĞIRLIK : 0.7Kg</p> </div> <div> <p>U2-R</p> <p>AĞIRLIK : 0.5Kg</p> </div> </div>
AĞIRLIK : 2Kg	

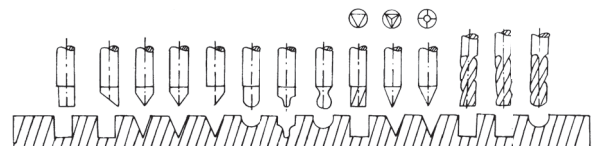
ZIMBA ve FREZE UÇ PROFİLLERİ

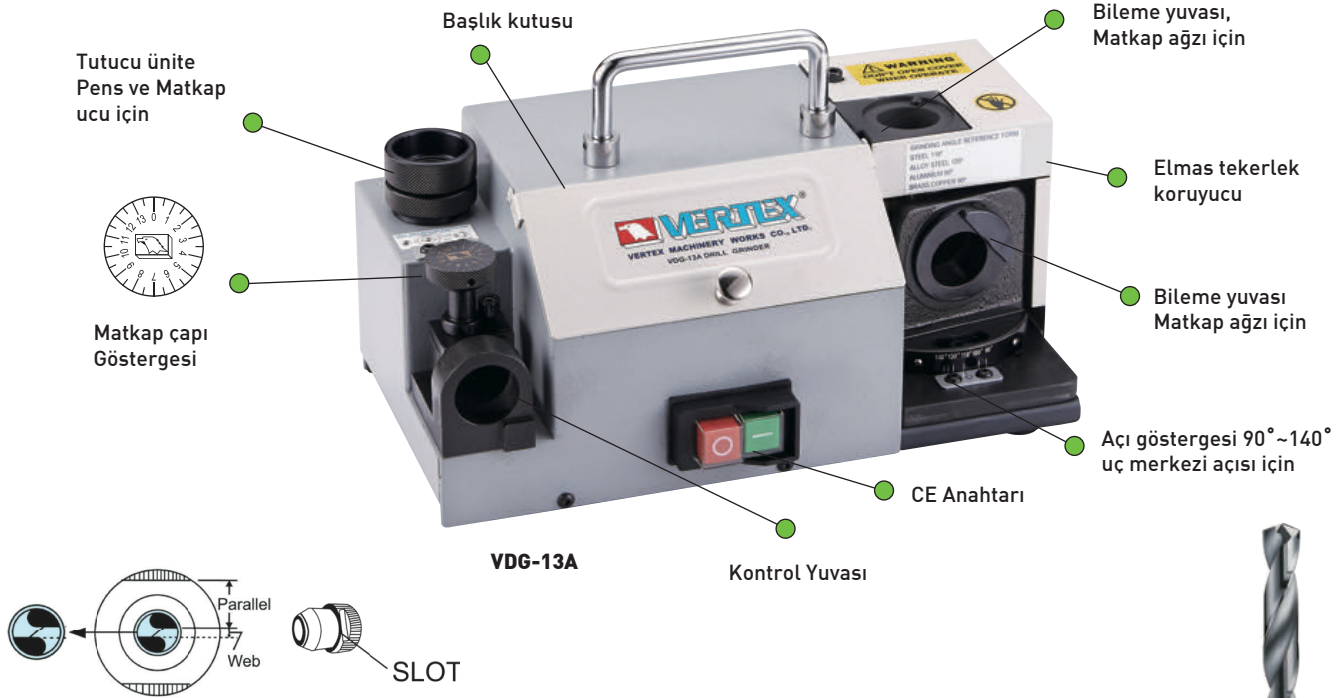
MATKAP BİLEME MAKİNASI

- MATKAP UÇLARININ BİLENMESİ İÇİN KULLANILIR.
- HASSAS ve KULLANIMI BASİTTİR.
- MATKAP UÇLARI HIZLI BİR ŞEKİLDE BİLENEBİLİR.
- $\pm 0,05$ mm HASSASİYET GARANTİLİDİR.
- GÜÇLÜ MOTORU 2 SAAT ÇALIŞMAYI DESTEKLER.
- KARBÜR ve HSS DAHİL HER TÜRLÜ MATKAP İÇİN UYGUNDUR.

- **KARBÜR BİLEME TAŞI İLE BİRLİKTE TESLİM EDİLİR**
- **KARBÜR TAŞ İLE HSS ÜRÜN BİLENMEZ**
- **HSS ÜRÜNLER İÇİN TAŞ TEMİN EDİLEBİLİR**

DETAYLAR

KOD	MATKAP ÇAPI	UÇ AÇISI	GÜÇ KAYNAĞI	MOTOR GÜCÜ	BİLEYİCİ	NET AĞIRLIK	ÖLÇÜLER	FİYAT USD
VDG-13A	Ø2.0-Ø13.0	90° - 140°	AC-110 veya 220 1PH	5100R.P.M.	SDC #200	9.7 Kgs	W282xD185xH110 mm	
VDG-25	Ø12-Ø25	100° - 136°	AC-110 veya 220 1PH	5300 R.P.M.	SDC #200	29 Kgs	W380xD240xH200 mm	

ÇANAK TAŞ

KOD	BİLENECEK MALZEME	TANE BÜYÜKLÜĞÜ	FİYAT USD
VDG-13B	HSS	CBN200	
VDG-13D	KARBÜR	SDC200	
VDG-25B	HSS	CBN200	
VDG-25D	KARBÜR	SDC200	

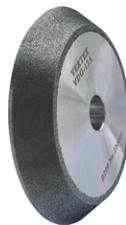
PENS

OPSİYONEL ÖZEL PENS ÖLÇÜLERİ	ER-20	ER-40 ÖZEL ÖLÇÜLERİ
	Ø 3.5, 4.5, 5.5, 6.5, 7.5, 8.5, 9.5, 10.5, 11.5, 12.5	Ø 8, 9, 10, 11, 26, 27, 28, 29,30

VDG-25

VDG-25 Ø30 mm'ye KADAR KULLANILABİLİR. BUNUN İÇİN LÜTFEN OPSİYONEL PENSLERİ TERCİH EDİN.

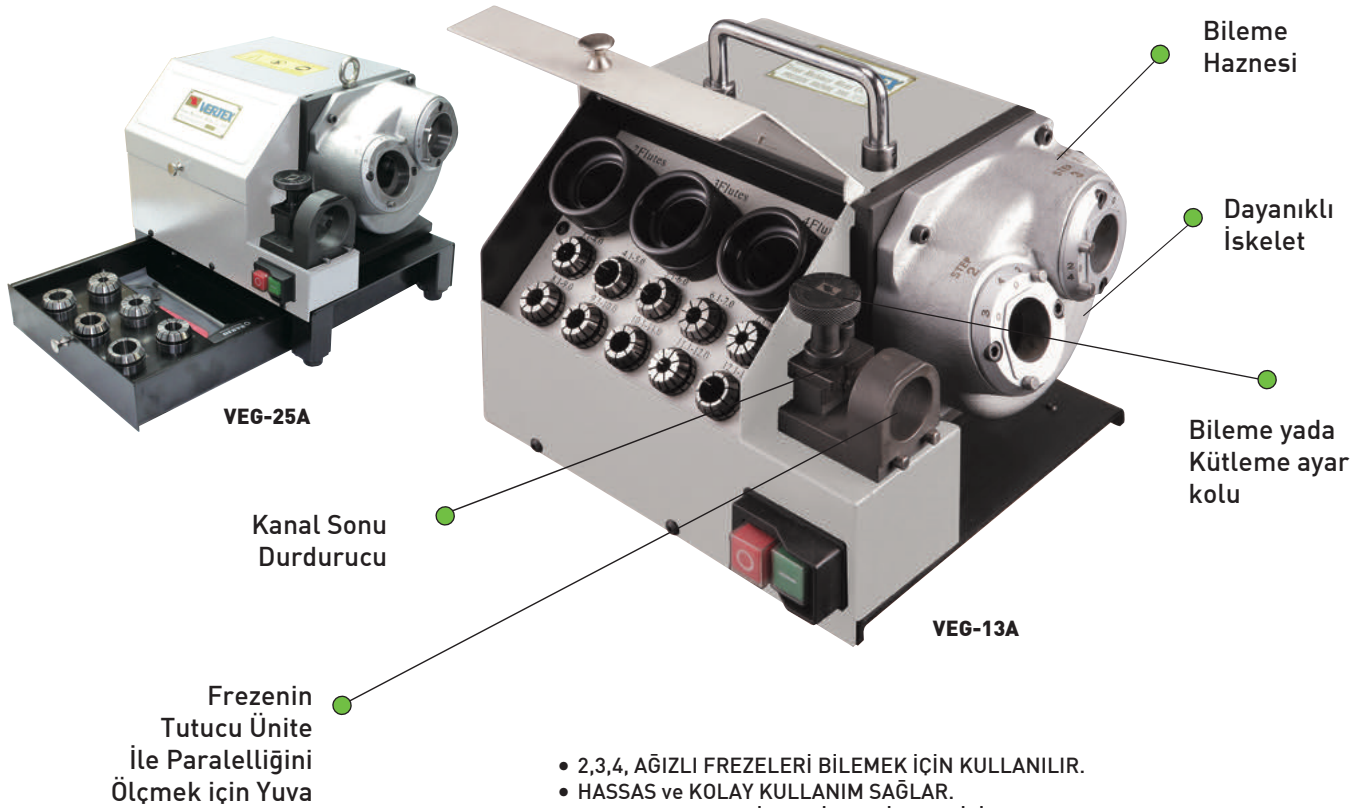
FREZE BİLEME MAKİNASI

- 2,3,4, AĞIZLI FREZELERİ BİLEMEK İÇİN KULLANILIR.
- HASSAS ve KOLAY KULLANIM SAĞLAR.
- FREZELER HIZLI BİR ŞEKİLDE BİLENEBİLİR.
- $\pm 0,02$ mm HASSASİYET GARANTİLİDİR.

- **KARBÜR BİLEME TAŞI İLE BİRLİKTE TESLİM EDİLİR**
- **KARBÜR TAŞ İLE HSS ÜRÜN BİLENMEZ**
- **HSS ÜRÜNLER İÇİN TAŞ TEMİN EDİLEBİLİR**

DETAYLAR

KOD	VEG-13A	VEG-25A
FREZE ÇAP ARALIĞI	Ø4- Ø13mm	Ø12~Ø25mm
MOTOR	450W	1000W
HIZ	4800rpm	4300rpm
GÜÇ	AC-110 veya 220 1PH 50/60HZ	AC-110 veya 220 1PH 50/60HZ
EKSENEL AÇI	NO.1 30° Derecelik düz yiv açısı NO.2 20° Derecelik ikinci radyal açısı NO.3 6° Derecelik kesme açısı	NO.1 30° Derecelik düz yiv açısı NO.2 20° Derecelik ikinci radyal açısı NO.3 6° Derecelik kesme açısı
STANDART AKSESUARLAR	Alaşımli Çelik Pens ER-20 Pens: Ø4, 5, 6, 7, 8, 9, 10, 11, 12, 13mm 10 adet/set, Anahtar:1 adet SDC 270 x1, Ø4 ~ Ø6mm için SDC 270 x1 Ø7~ Ø13mm için Kare Tip 4 Ağızlı freze için x 1 Set Hex. Tip 3 Ağızlı freze için x 1 Set Paralel Tip 2 Ağızlı freze için x 1 Set	Alaşımli Çelik Pens ER-40 Pens: Ø12, 16, 18, 20, 22, 25mm 6 adet/set, Anahtar:1 adet SDC 150 x1 Ø12 ~ Ø25mm için Kare Tip 4 Ağızlı freze için x 1 Set Hex. Tip 3 Ağızlı freze için x 1 Set Paralel Tip 2 Ağızlı freze için x 1 Set
PAKET ÖLÇÜLERİ	320x260x300mm	365x293x345mm
AĞIRLIK (Kg)	17	31
FİYAT USD		

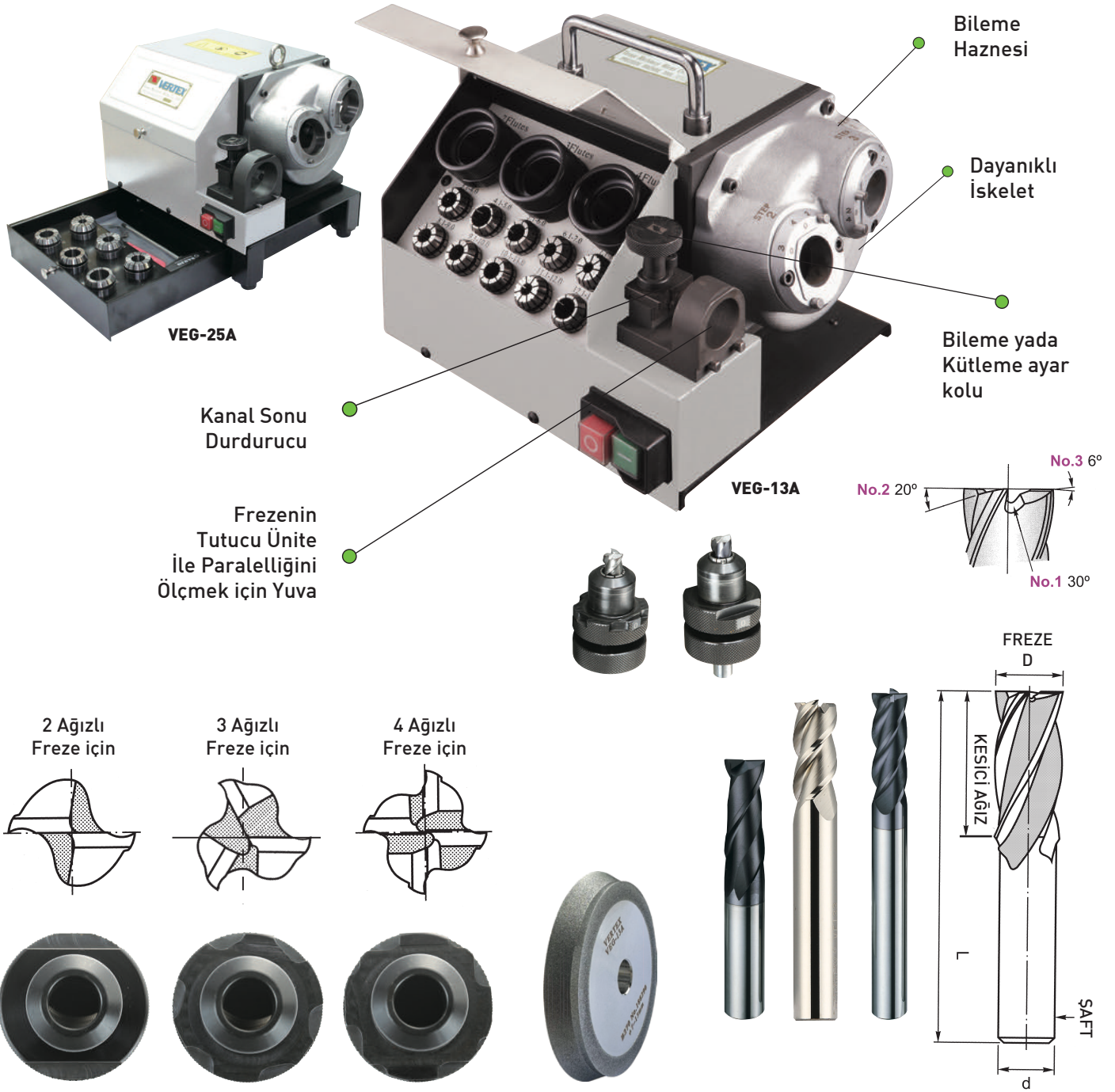
HASSAS FREZE BİLEME MAKİNASI YEDEK TAŞLARI

* HER TUTUCU ÜZERİNE 2,3 ve 4 KONUMLARI İŞARETLENMİŞTİR

OPSİYONEL AKSESUAR

KOD	BİLEME TAŞI	KULLANILACAĞI MAZEME	AĞIRLIK (Kg)	FİYAT USD
VEG-13BS	CBN 300x1 (Ø4 ~ 6mm için)	H.S.S	0,35	
VEG-13BL	CBN 270x1 (Ø7 ~ 13mm için)	H.S.S	0,35	
VEG-13DS	SDC 270x1 (Ø4 ~ 6mm için)	KARBÜR	0,35	
VEG-13DL	SDC 270x1 (Ø7 ~ 13mm için)	KARBÜR	0,35	
VEG-25BSV	CBN 150x1 (Ø12 ~ 25mm için)	H.S.S	0,85	
VEG-25DSV	SDC 150x1 (Ø12 ~ 25mm için)	KARBÜR	0,85	