

METRİK NORMAL DIŞ PAFTA HSS				NB-223M	NB-223ML SOL
d	P	D	E	FİYAT EUR	FİYAT EUR
M2	0,4	16	5		
M2,5	0,45	16	5		
M3	0,5	20	5		
M3,5	0,6	20	5		
M4	0,7	20	5		
M4,5	0,75	20	7		
M5	0,8	20	7		
M6	1	20	7		
M7	1	25	9		
M8	1,25	25	9		
M9	1,25	25	9		
M10	1,5	30	11		
M11	1,5	30	11		
M12	1,75	38	14		
M14	2	38	14		
M16	2	45	18		
M18	2,5	45	18		
M20	2,5	45	18		
M22	2,5	55	22		
M24	3	55	22		
M25	3	55	22		
M26	3	55	22		
M27	3	65	25		
M30	3,5	65	25		
M33	3,5	65	25		
M36	4	65	25		
M39	4	75	30		
M42	4,5	75	30		
M45	4,5	90	36		
M48	5	90	36		
M52	5	90	36		
HSS → Yüksek hız çeliği				KULLANIM ALANI	
				El ve makinalarda kullanmaya uygundur. Eğik ağız bileme özelliği ile temiz vida elde edilir. Tüm çelik türlerinde kullanıma uygundur.	El ve makinalarda kullanmaya uygundur. Eğik ağız bileme özelliği ile temiz vida elde edilir. Tüm çelik türlerinde kullanıma uygundur. Sol diş açma işleminde kullanılır.

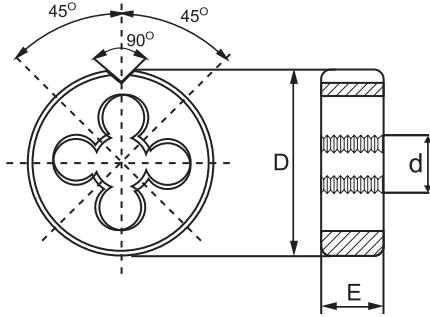

METRİK İNCE DİŞ PAFTA HSS				NB-223M	NB-223ML SOL
d	P	D	E	FİYAT EUR	FİYAT EUR
M3	0,35	20	5		
M3,5	0,35	20	5		
M4	0,5	20	5		
M4	0,35	20	5		
M4,5	0,5	20	5		
M5	0,5	20	5		
M5,5	0,5	20	5		
M6	0,75	20	7		
M6	0,5	20	7		
M7	0,75	25	9		
M7	0,5	25	9		
M8	1	25	9		
M8	0,75	25	9		
M8	0,5	25	9		
M9	1	25	9		
M9	0,75	25	9		
M10	1,25	30	11		
M10	1	30	11		
M10	0,75	30	11		
M10	0,5	30	11		
M11	1,25	30	11		
M11	1	30	11		
M12	1,5	38	10		
M12	1,25	38	10		
M12	1	38	10		
M12	0,75	38	10		
M13	1,5	38	10		
→ Yüksek hız çeliği				KULLANIM ALANI El ve makinalarda kullanmaya uygundur. Eğik ağız bileme özelliği ile temiz vida elde edilir. Tüm çelik türlerinde kullanıma uygundur.	El ve makinalarda kullanmaya uygundur. Eğik ağız bileme özelliği ile temiz vida elde edilir. Tüm çelik türlerinde kullanıma uygundur. Sol diş açma işleminde kullanılır.

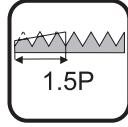

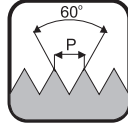
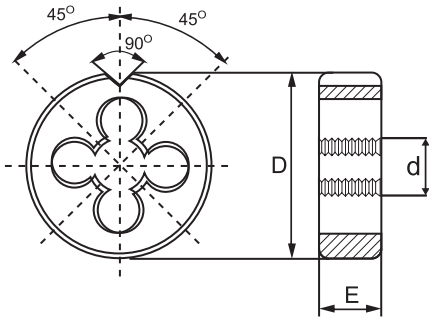
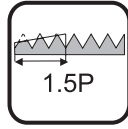
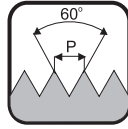

METRİK İNCE DİŞ PAFTA HSS				NB-223M	NB-223ML SOL
d	P	D	E	FİYAT EUR	FİYAT EUR
M13	1,25	38	10		
M13	1	38	10		
M14	1,5	38	10		
M14	1,25	38	10		
M14	1	38	10		
M14	0,75	38	10		
M15	1,5	38	10		
M15	1,25	38	10		
M15	1	38	10		
M16	1,5	45	14		
M16	1,25	45	14		
M16	1	45	14		
M17	1,5	45	14		
M17	1	45	14		
M18	2	45	14		
M18	1,5	45	14		
M18	1,25	45	14		
M18	1	45	14		
M19	1,5	45	14		
M20	2	45	14		
M20	1,5	45	14		
M20	1	45	13		
M21	1,5	55	16		
M22	2	55	16		
M22	1,5	55	16		
M22	1,25	55	16		
M22	1	55	15		
M23	1,5	55	16		
→ Yüksek hız çeliği				KULLANIM ALANI El ve makinalarda kullanmaya uygundur. Eğik ağız bileme özelliği ile temiz vida elde edilir. Tüm çelik türlerinde kullanıma uygundur.	El ve makinalarda kullanmaya uygundur. Eğik ağız bileme özelliği ile temiz vida elde edilir. Tüm çelik türlerinde kullanıma uygundur. Sol diş açma işleminde kullanılır.



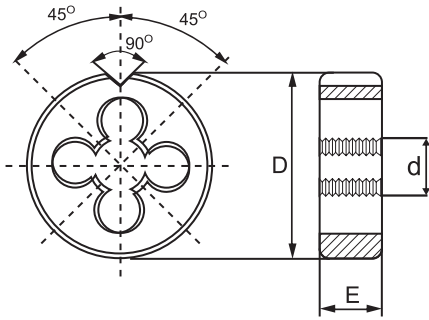
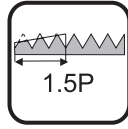
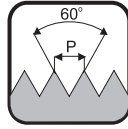

METRİK İNCE DİŞ PAFTA HSS				NB-223M	NB-223ML SOL
d	P	D	E	FİYAT EUR	FİYAT EUR
M24	2	55	16		
M24	1,5	55	16		
M24	1,25	55	16		
M24	1	55	16		
M25	2	55	16		
M25	1,5	55	16		
M25	1	55	16		
M26	2	55	16		
M26	1,5	55	16		
M26	1	55	16		
M27	2	65	18		
M27	1,5	65	18		
M27	1	65	18		
M28	2	65	18		
M28	1,5	65	18		
M28	1	65	18		
M29	1,5	65	18		
M30	3	65	18		
M30	2,5	65	18		
M30	2	65	18		
M30	1,5	65	18		
M30	1	65	18		
M32	3	65	18		
M32	2	65	18		
M32	1,5	65	18		
M33	3	65	18		
M33	2	65	18		
M33	1,5	65	18		
→ Yüksek hız çeliği				KULLANIM ALANI El ve makinalarda kullanmaya uygundur. Eğik ağız bileme özelliği ile temiz vida elde edilir. Tüm çelik türlerinde kullanıma uygundur.	El ve makinalarda kullanmaya uygundur. Eğik ağız bileme özelliği ile temiz vida elde edilir. Tüm çelik türlerinde kullanıma uygundur. Sol diş açma işleminde kullanılır.



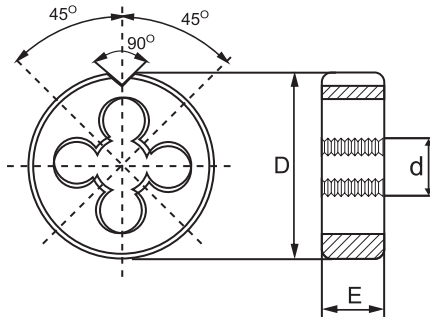

METRİK İNCE DİŞ PAFTA HSS				NB-223M	NB-223M SOL
d	P	D	E	FİYAT EUR	FİYAT EUR
M34	2	65	18		
M34	1,5	65	18		
M35	2	65	18		
M35	1,5	65	18		
M36	3	65	25		
M36	2	65	18		
M36	1,5	65	18		
M38	2	75	20		
M38	1,5	65	20		
M39	3	75	30		
M39	2	75	20		
M39	1,5	75	20		
M40	3	75	30		
M40	2	75	20		
M40	1,5	75	20		
M42	3	75	30		
M42	2	75	20		
M42	1,5	75	20		
M45	3	90	36		
M45	2	90	22		
M45	1,5	90	22		
M48	3	90	36		
M48	2	90	22		
M48	1,5	90	22		
M50	3	90	36		
M50	2	90	22		
M50	1,5	90	22		
M52	3	90	36		
M52	2	90	22		
M52	1,5	90	22		
HSS → Yüksek hız çeliği				KULLANIM ALANI El ve makinalarda kullanmaya uygundur. Eğik ağız bileme özelliği ile temiz vida elde edilir. Tüm çelik türlerinde kullanıma uygundur.	KULLANIM ALANI El ve makinalarda kullanmaya uygundur. Eğik ağız bileme özelliği ile temiz vida elde edilir. Tüm çelik türlerinde kullanıma uygundur. Sol diş açma işleminde kullanılır.

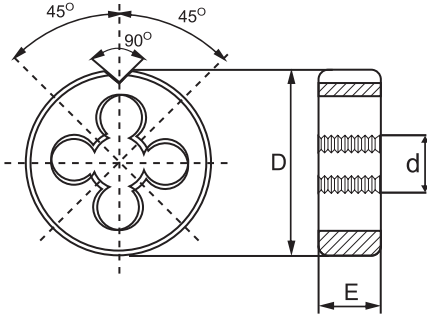

GAZ DİŞ PAFTA HSS				NB-223G
d	P	D	E	FİYAT EUR
G 1/16	28	25	9	
G 1/8	28	30	11	
G 1/4	19	38	10	
G 3/8	19	45	14	
G 1/2	14	45	14	
G 5/8	14	55	16	
G 3/4	14	55	16	
G 7/8	14	65	18	
G 1	11	65	18	
G 1 1/8	11	75	20	
G 1 1/4	11	75	20	
G 1 3/8	11	90	22	
G 1 1/2	11	90	22	
G 1 3/4	11	105	22	
G 2	11	105	22	

HSS → Yüksek hız çeliği

KULLANIM ALANI

El ve makinalarda kullanmaya uygundur.
Eğik ağız bileme özelliği ile temiz vida elde edilir.
Tüm çelik türlerinde kullanıma uygundur.

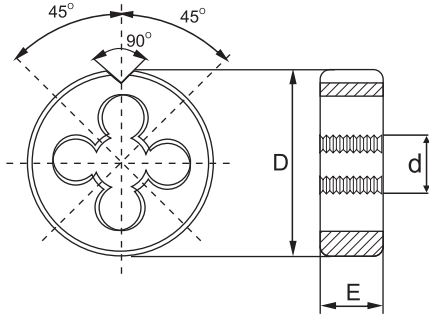
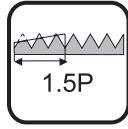
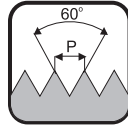

UNF PAFTA HSS				NB-223UNF
d	P	D	E	FİYAT EUR
UNF NR4	48	20	5	
UNF NR5	44	20	5	
UNF NR6	40	20	5	
UNF NR8	36	20	7	
UNF NR10	32	20	7	
UNF NR12	28	20	7	
UNF 1/4	28	20	7	
UNF 5/16	24	25	9	
UNF 3/8	24	30	11	
UNF 7/16	20	30	11	
UNF 1/2	20	38	10	
UNF 9/16	18	38	10	
UNF 5/8	18	45	14	
UNF 3/4	16	45	14	
UNF 7/8	14	55	16	
UNF 1	12	55	16	
UNF 1	14	55	16	
UNF 1 1/8	12	65	18	
UNF 1 1/4	12	65	18	
UNF 1 1/2	12	75	20	
→ Yüksek hız çeliği				KULLANIM ALANI El ve makinalarda kullanmaya uygundur. Eğik ağız bileme özelliği ile temiz vida elde edilir. Tüm çelik türlerinde kullanıma uygundur.

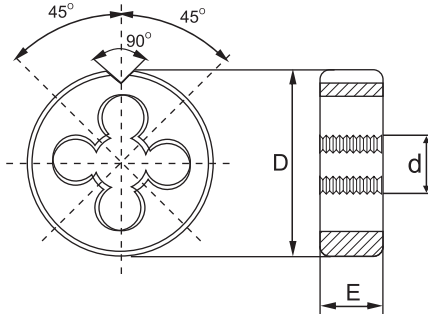

UNC PAFTA HSS				NB-223UNC
d	P	D	E	FİYAT EUR
UNC NR4	40	20	5	
UNC NR5	40	20	5	
UNC NR6	32	20	7	
UNC NR8	32	20	7	
UNC NR10	24	20	7	
UNC NR12	24	20	7	
UNC 1/4	20	20	7	
UNC 5/16	18	25	9	
UNC 3/8	16	30	11	
UNC 7/16	14	30	11	
UNC 1/2	13	38	14	
UNC 9/16	12	38	14	
UNC 5/8	11	45	18	
UNC 3/4	10	45	18	
UNC 7/8	9	55	22	
UNC 1	8	55	22	
UNC 1 1/8	7	65	25	
UNC 1 1/4	7	65	25	
UNC 1 1/2	6	75	30	
 → Yüksek hız çeliği			KULLANIM ALANI	El ve makinalarda kullanmaya uygundur. Eğik ağız bileme özelliği ile temiz vida elde edilir. Tüm çelik türlerinde kullanıma uygundur.

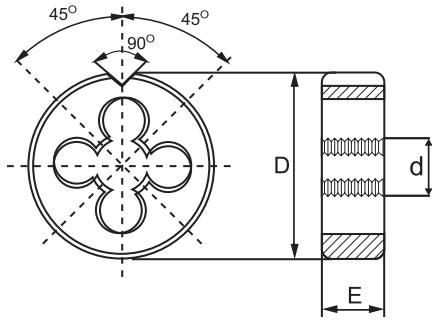
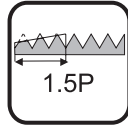
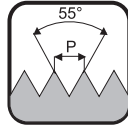

WHITWORTH PAFTA HSS				NB-223W
d	P	D	E	FİYAT EUR
W 1/8	40	20	5	
W 5/32	32	20	5	
W 3/16	24	20	7	
W 1/4	20	20	7	
W 5/16	18	25	9	
W 3/8	16	20	11	
W 7/16	14	30	11	
W 1/2	12	38	14	
W 9/16	12	38	14	
W 5/8	11	45	18	
W 3/4	10	45	18	
W 7/8	9	55	22	
W 1	8	55	22	
 → Yüksek hız çeliği			KULLANIM ALANI	El ve makinalarda kullanmaya uygundur. Eğik ağız bileme özelliği ile temiz vida elde edilir. Tüm çelik türlerinde kullanıma uygundur.

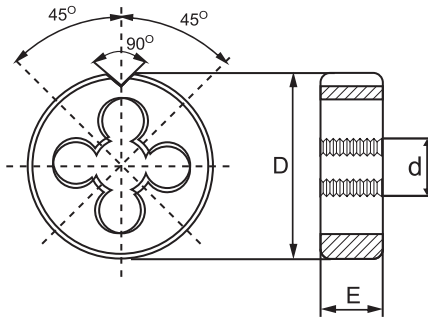

NPT (KONİK) PAFTA HSS				NB-223NPT
d	P	D	E	FİYAT EUR
NPT 1/16	27	25	10	
NPT 1/8	27	30	11	
NPT 1/4	18	38	14	
NPT 3/8	18	45	18	
NPT 1/2	14	45	18	
NPT 3/4	14	55	22	
NPT 1	11,5	65	25	
NPT 1 1/4	11,5	75	26	
NPT 1 1/2	11,5	90	27	
NPT 2	11,5	105	28	
HSS → Yüksek hız çeliği				KULLANIM ALANI El ve makinalarda kullanmaya uygundur. Eğik ağız bileme özelliği ile temiz vida elde edilir. Tüm çelik türlerinde kullanıma uygundur.

KILAVUZ - PAFTA TAKIMI HSS











KOD	ÖLÇÜ ARALIĞI	ÖLÇÜ	FİYAT EUR
NB-986	M3-M12	M3-M4-M5-M6-M8-M10-M12	
NB-987	M12-M20	M12-M14-M16-M18-M20	
NB-988	M3-M24	M3-M4-M5-M6-M8-M10-M12-M14-M16-M18-M20-M22-M24	
NB-989W1*	W1/8"-W1/2"	W1/8-3/16-1/4-5/16-3/8-7/16-1/2 (CS)	
NB-989W2*	W1/2"-W1"	W1/2-9/16-5/8-3/4-7/8-1 (CS)	
NB-989UNC1*	UNC1/4"-UNC1/2"	UNC1/4-5/16-3/8-7/16-1/2 (CS)	
NB-989UNC2*	UNC1/2"-UNC1"	UNC1/2-5/8-3/4-7/8-1 (CS)	
NB-989UNF1*	UNF1/4"-UNF1/2"	UNF1/4-5/16-3/8-7/16-1/2 (CS)	
NB-989UNF2*	UNF1/2"-UNF1"	UNF1/2-5/8-3/4-7/8-1 (CS)	
NB-990G*	G1/8"-G1"	G1/8-1/4-3/8-1/2-5/8-3/4-7/8-1 (CS)	

* AHŞAP KUTU

KILAVUZ - PAFTA TAKIMI HSS (HOBBY SET)



KOD	SET İÇERİĞİ				FİYAT EUR
NB-985	 M3-4-5-6-8-10-12	 M3-4-5-6-8-10-12	 Ø2,5-3,3-4,2-5 6,8-8,5-10,2		
	 2,5-7,1 mm	 Ø 25 mm			

ÇELİK KILAVUZ KOLU

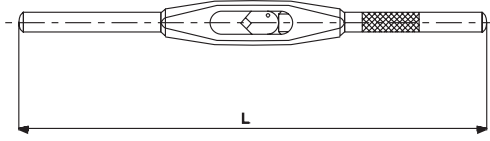

KOD	L (mm)	ÖLÇÜ (mm)	FİYAT EUR
NB-350-15S	125	1-1/2 (M2 - M7)	
NB-350-20S	210	2 (M3 - M12)	
NB-350-30S	310	3 (M6 - M16)	
NB-350-40S	400	4 (M9 - M27)	
NB-350-50S	700	5 (M24 - M52)	

PAFTA KOLU

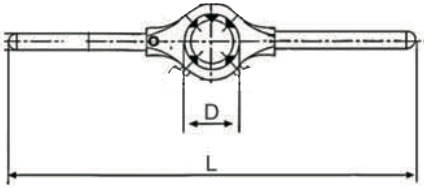

KOD	D (mm)	L (mm)	FİYAT EUR
NB-40316	16	140	
NB-40320	20	170	
NB-40325	25	210	
NB-40330	30	270	
NB-40338	38	325	
NB-40345	45	400	
NB-40355	55	475	
NB-40365	65	555	
NB-40375	75	555	

KILAVUZ UZATMA KOLU

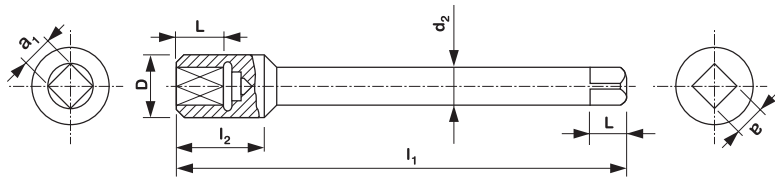

KILAVUZ UZATMA KOLU DIN 377								NB-351
KILAVUZ	a (mm)	d ₂	D	l	l ₁	l ₂	l ₃	FİYAT EUR
M2	2,1	2,8	5	5	60	15	6	
M3	2,7	3,5	7	6	80	20	7	
M4	3,4	4,5	8	6	95	22	7	
M5-6	4,9	6	11	8	110	25	9	
G1/8	5,5	7	11	8	115	27	9	
M8	6,2	8	14	9	120	29	10	
M12	7	9	15	10	125	31	11	
M10	8	10	17	11	125	31	12	
M14-16	9	12	19	12	130	33	14	
M18	11	14	23	14	150	39	16	
M20	12	16	25	15	155	41	17	
M22-24	14,5	18	29	17	175	47	19	

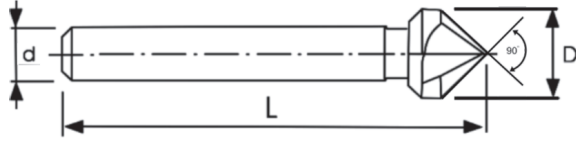

HSS



HSS TİN

HAVŞA FREZE 90° DIN 335/C 3 AĞIZLI			NB-335	NB-335T
			HSS	HSS
D	d	L	FİYAT EUR	FİYAT EUR
6,3	5	45		
8	6	46/50		
10	6	46/50		
11,5	8	56		
12	8	46/54		
12,4	8	54		
16	8	46,5/60		
16,5	10	60		
20	10	47/63		
20,5	10	63		
23	10	67		
25	10	51/66		
25,5	10	66		
30	12	71		
31,5	12	71		
35	12	80		
40	13	80		
50	13	85		
<p>HSS → Yüksek hız çeliği</p> <p>TİN → Titanyum Nitrür</p>			<p>KULLANIM ALANI</p> <ul style="list-style-type: none"> • Demir ve demir dışı metallerde • Yumuşak malzemelerde • Delme işlemlerinde • Havşalama işlemlerinde 	

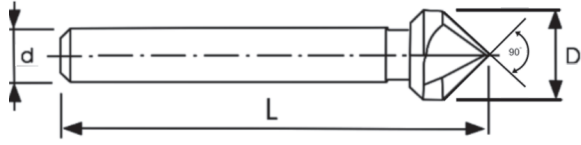

HSSE VA

HAVŞA FREZE 90° DIN 335/C 3 AĞIZLI HSSE VA (PASLANMAZ İÇİN)			NB-335 PS
			HSSE VA
D	d	L	FİYAT EUR
6,3	5	45	
8	6	50	
10	6	50	
12,4	8	56	
16,5	10	60	
20,5	10	63	
25	10	68	
30	12	71	
40	12	80	

HSSE VA → Süper yüksek hız çeliği
Paslanmaz çelikler için

KULLANIM ALANI

- Paslanmaz malzemelerde
- Demir ve demir dışı metallerde
- Yumuşak malzemelerde
- Delme işlemlerinde
- Havşalama işlemlerinde

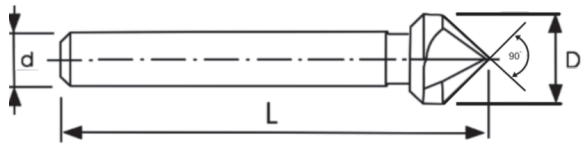
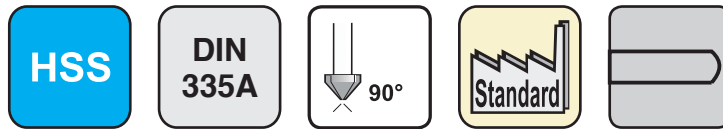

HSS

HAVŞA FREZE 90° DIN 335/A ÇOK AĞIZLI			NB-333
			HSS
D	d	L	FİYAT EUR
8	8	48	
12,5	8	48	
16	10	56	
20	10	60	
25	10	67	

HSS → Yüksek hız çeliği

KULLANIM ALANI

- Demir ve demir dışı metallerde
- Yumuşak malzemelerde
- Delme işlemlerinde
- Havşalama işlemlerinde

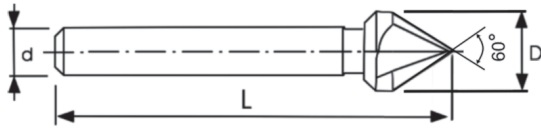

HAVŞA FREZE 60° DIN 334/C ÜÇ AĞIZLI				NB-334
				HSS
D	d	L	FİYAT EUR	
6,3	5	45		
8	6	50		
10	6	56		
12,5	8	56		
16	10	63		
20	10	67		
25	10	71		
 Yüksek hız çeliği			KULLANIM ALANI <ul style="list-style-type: none"> • Demir ve demir dışı metallerde • Yumuşak malzemelerde • Delme işlemlerinde • Havşalama işlemlerinde 	

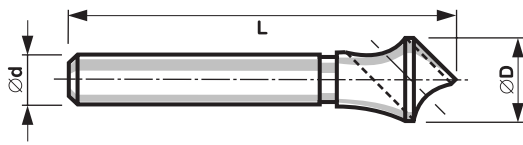

HAVŞA FREZE DELİKLİ (ZENKER) 90°				NB-332
				HSS
ÖLÇÜ	D	d	L	FİYAT EUR
2/5	10	6	46	
5/10	14	8	46	
10/15	21,5	10	64,5	
15/20	28	12	80	
20/25	35	15	97	
25/30	44	15	115	
 Yüksek hız çeliği			KULLANIM ALANI <ul style="list-style-type: none"> • Demir ve demir dışı metallerde • Yumuşak malzemelerde • Havşalama işlemlerinde 	