

KISA PARMAK FREZE DIN 844					C210 HSS	C210 HSS TİN			
D k10	l	L	d h6	Z	FİYAT USD	FİYAT USD			
1	4	48	6	2					
1,5	4	48	6	2					
2	7	51	6	4					
2,5	8	52	6	4					
3	8	52	6	4					
4	11	55	6	4					
5	13	57	6	4					
6	13	57	6	4					
7	16	66	10	4					
8	19	69	10	4					
9	19	69	10	4					
10	22	72	10	4					
11	22	79	12	4					
12	26	83	12	4					
13	26	83	12	4					
14	26	83	12	4					
15	26	83	12	4					
16	32	92	16	4					
17	32	92	16	4					
18	32	92	16	4					
19	38	104	16	4					
20	38	104	20	4					
21	38	104	20	4					
22	38	104	20	4					
23	38	121	20	4					
24	45	121	25	4					
25	45	121	25	4					
26	45	121	25	4					
27	45	121	25	4					
28	45	121	25	4					
29	45	121	25	4					
30	45	121	25	4					
31	53	133	25	4					
32	53	133	32	4					
33	53	133	32	4					
34	53	133	32	4					
35	53	133	32	4					
36	53	133	32	4					
37	53	133	32	4					
38	53	133	32	4					
39	63	155	32	6					
40	63	155	32	6					
TEKNİK ÖZELLİKLERİ					HSS	DIN 1835A	HSS	TİN	DIN 1835A
<p>Type N → Genel kullanım içindir. Çekme dayanımı 900 MPa'a kadar olan malzemeler için.</p> <p>HSS → Yüksek hız çeliği</p> <p>TİN → Titanyum Nitrür</p>					KULLANIM ALANI				
					<ul style="list-style-type: none"> Alaşımsız çelikler (180 HB) Yapı çelikleri (Sertlik:24 Hrc) Sementasyon nitrasyon çelikleri (Sertlik:27,1 Hrc) Dökme demir (Max.240 HB) Alüminyum ve alaşımları (152 HB) 				

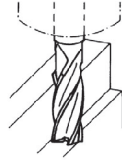
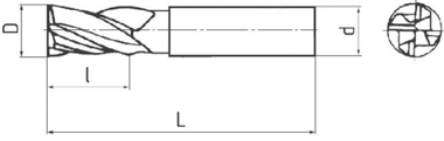
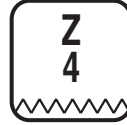
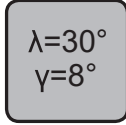

UZUN PARMAK FREZE DIN 844

C240

HSS

FİYAT USD

D	l	L	d h6	Z	
3	12	56	6	4	
4	19	63	6	4	
5	24	68	6	4	
6	24	68	6	4	
7	30	80	10	4	
8	38	88	10	4	
9	38	88	10	4	
10	45	95	10	4	
11	45	110	12	4	
12	53	110	12	4	
13	53	110	12	4	
14	53	110	12	4	
15	53	123	12	4	
16	63	123	16	4	
17	63	123	16	4	
18	63	123	16	4	
19	63	123	16	4	
20	75	141	20	4	
21	75	141	20	4	
22	75	141	20	4	
23	75	141	20	4	
24	90	166	25	4	
25	90	166	25	4	
26	90	166	25	4	
27	90	166	25	4	
28	90	166	25	4	
29	90	166	25	4	
30	90	166	25	4	
31	106	186	32	4	
32	106	186	32	4	
33	106	186	32	4	
34	106	186	32	4	
35	106	186	32	4	
36	106	186	32	4	
37	106	186	32	4	
38	106	186	32	4	
39	125	205	32	6	
40	125	205	32	6	

TEKNİK ÖZELLİKLERİ



Genel kullanım içindir.
Çekme dayanımı 900 MPa'a kadar olan malzemeler için.



Yüksek hız çeliği



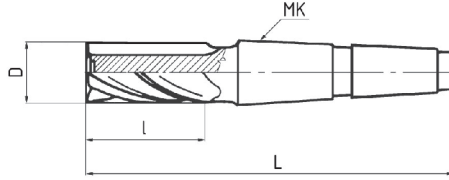
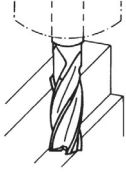
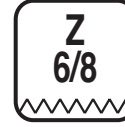
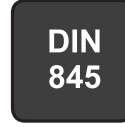
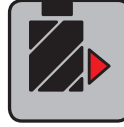
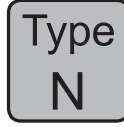
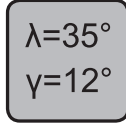

KULLANIM ALANI

- Alaşimsız çelikler (180 HB)
- Yapı çelikleri (Sertlik:24 Hrc)
- Sementasyon nitrasyon çelikleri (Sertlik:27,1 Hrc)
- Dökme demir (Max.240 HB)
- Dökme demir (Min.240 HB)
- Korozyona ve asite dayanıklı çelikler (Sertlik:24,8 Hrc)
- Bakır ve alaşımları (Sertlik:22,2 Hrc)
- Alüminyum ve alaşımları (152 HB)

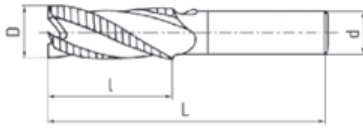
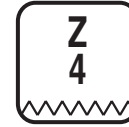
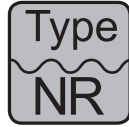
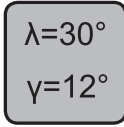





KONİK SAPLI PARMAC FREZE					C210MK
					HSS
D	l	L	MK	Z	FİYAT USD
36	53	178	4	6	
40	63	188	4	6	
45	63	188	4	6	
50	75	233	5	8	
56	75	233	5	8	
63	90	248	5	8	
<p>Type N → Genel kullanım içindir. Çekme dayanımı 900 MPa'a kadar olan malzemeler için.</p> <p>HSS → Yüksek hız çeliği</p>				KULLANIM ALANI	<ul style="list-style-type: none"> • Alaşimsız çelikler (180 HB) • Yapı çelikleri (Sertlik:24Hrc) • Sementasyon nitrasyon çelikleri (Sertlik:27,1 Hrc) • Dökme demir (Max.240 HB) • Alüminyum ve alaşımları (152 HB)

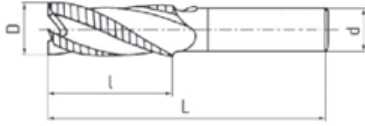
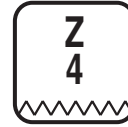
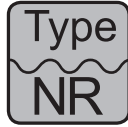
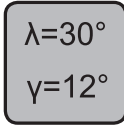

KISA KABATALAŞ FREZE DIN 844 NR						C230 HSS
D	l	L	d h6	Z		FİYAT USD
4	13	57	6	4		
5	13	57	6	4		
6	13	57	6	4		
7	16	66	10	4		
8	19	69	10	4		
9	19	69	10	4		
10	22	72	10	4		
11	22	79	12	4		
12	26	83	12	4		
13	26	83	12	4		
14	26	83	12	4		
15	26	83	12	4		
16	32	92	16	4		
17	32	92	16	4		
18	32	92	16	4		
19	38	104	20	4		
20	38	104	20	4		
22	38	104	20	4		
24	45	121	25	4		
25	45	121	25	4		
26	45	121	25	4		
28	45	121	25	4		
30	45	121	25	4		
32	53	133	32	4		
36	53	133	32	4		
40	63	143	32	4		
TEKNİK ÖZELLİKLERİ						 
 <p>Düşük ve orta dayanımlı malzemelerin (700 MPa'a kadar) kaba operasyonları için kullanılır Yüzey kalitesi Ra 12,5 ve daha yüksek</p>				KULLANIM ALANI		<ul style="list-style-type: none"> Alaşsız çelikler (180 HB) Yapı çelikleri (Sertlik:24 Hrc) Sementasyon nitrasyon çelikleri (Sertlik:27,1 Hrc) Dökme demir (Max.240 HB) Korozyona ve asite dayanıklı çelikler (Sertlik:24,8 Hrc)
 <p>Yüksek hız çeliği</p>						



UZUN KABATALAŞ FREZE DIN 844 NR						C232 HSS
D	l	L	d h6	Z		FİYAT USD
6	24	68	6	4		
7	24	68	6	4		
8	38	88	10	4		
9	45	88	10	4		
10	45	95	10	4		
11	53	95	10	4		
12	53	110	12	4		
13	53	110	12	4		
14	53	110	12	4		
16	63	123	16	4		
17	63	123	16	4		
18	63	123	16	4		
20	75	141	20	4		
22	75	141	20	4		
24	90	166	25	4		
25	90	166	25	4		
26	90	166	25	4		
28	90	166	25	4		
30	90	166	25	4		
32	106	186	32	4		
36	106	186	32	4		
40	125	186	32	4		
TEKNİK ÖZELLİKLERİ						 
 <p>Düşük ve orta dayanımlı malzemelerin (700 MPa'a kadar) kaba operasyonları için kullanılır Yüzey kalitesi Ra 12,5 ve daha yüksek</p>				KULLANIM ALANI		<ul style="list-style-type: none"> Alaşımsız çelikler (180 HB) Yapı çelikleri (Sertlik:24 Hrc) Sementasyon nitrasyon çelikleri (Sertlik:27,1 Hrc) Dökme demir (Max.240 HB)
 <p>Yüksek hız çeliği</p>						

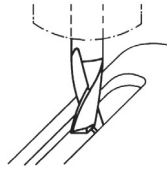
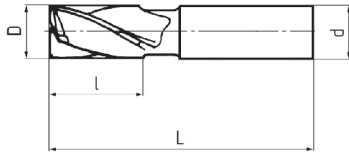
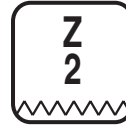
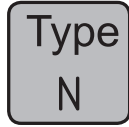
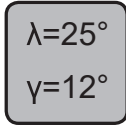

İKİ AĞIZLI KISA DELİK FREZESİ DIN 327

C220

HSS

FİYAT USD

D	l	L	d h6	Z	FİYAT USD
3	5	49	6	2	
4	7	51	6	2	
5	8	52	6	2	
6	8	52	6	2	
7	10	60	10	2	
8	11	61	10	2	
9	11	61	10	2	
10	13	63	10	2	
11	13	70	12	2	
12	16	73	12	2	
13	16	73	12	2	
14	16	73	12	2	
15	16	73	12	2	
16	19	79	16	2	
18	19	79	16	2	
20	22	88	20	2	
22	22	88	20	2	
24	26	102	25	2	
25	26	102	25	2	
26	26	102	25	2	
28	26	102	25	2	
30	26	102	25	2	

TEKNİK ÖZELLİKLERİ



Genel kullanım içindir.
Çekme dayanımı 900 MPa'a
kadar olan malzemeler için.



Yüksek hız çeliği

KULLANIM ALANI

- Alaşimsız çelikler (180 HB)
- Yapı çelikleri (Sertlik:24 Hrc)
- Sementasyon nitrasyon çelikleri (Sertlik:27,1 Hrc)
- Dökme demir (Max.240 HB)
- Dökme demir (Min.240 HB)
- Alüminyum ve alaşımları (152 HB)
- Bakır ve alaşımları (Sertlik:22,2 Hrc)
- Alüminyum ve alaşımları (152 HB)

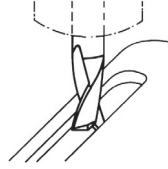
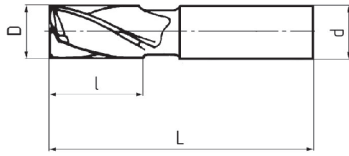
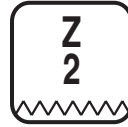
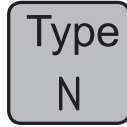
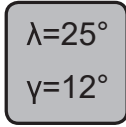

İKİ AĞIZLI UZUN FREZE DIN 327					C222
					HSS
D e8	l	L	d h6	Z	FİYAT USD
3	11	63	6	2	
4	11	63	6	2	
5	13	68	6	2	
6	13	68	6	2	
7	16	80	10	2	
8	19	88	10	2	
9	19	88	10	2	
10	22	95	10	2	
11	22	102	12	2	
12	26	110	12	2	
13	26	110	12	2	
14	26	110	12	2	
15	26	110	12	2	
16	32	123	16	2	
18	32	123	16	2	
20	38	141	20	2	
TEKNİK ÖZELLİKLERİ					HSS 
<p>Type N → Genel kullanım içindir. Çekme dayanımı 900 MPa'a kadar olan malzemeler için.</p> <p>HSS → Yüksek hız çeliği</p>		KULLANIM ALANI		<ul style="list-style-type: none"> • Alaşsız çelikler (180 HB) • Yapı çelikleri (Sertlik:24 Hrc) • Sementasyon nitrasyon çelikleri (Sertlik:27,1 Hrc) • Dökme demir (Max.240 HB) • Dökme demir (Min.240 HB) • Alüminyum ve alaşımları (152 HB) • Bakır ve alaşımları (Sertlik:22,2 Hrc) • Alüminyum ve alaşımları (152 HB) 	

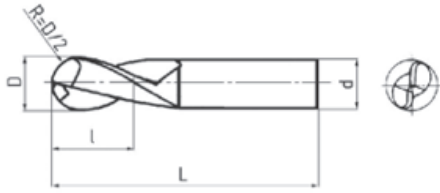
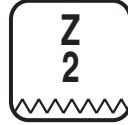
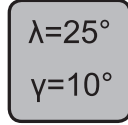

İKİ AĞIZLI KISA KÜRESEL FREZE DIN 1889

C221

HSS

FİYAT USD

D k10	l	L	d h6	FİYAT USD
3	7	51	6	
4	7	51	6	
5	8	52	6	
6	8	52	6	
7	10	60	10	
8	11	61	10	
9	11	61	10	
10	13	63	10	
11	13	70	12	
12	16	73	12	
13	16	73	12	
14	16	73	12	
15	16	73	12	
16	19	79	16	
17	19	79	16	
18	19	79	16	
19	19	79	16	
20	22	88	20	
22	22	88	20	
24	26	102	25	
25	26	102	25	

TEKNİK ÖZELLİKLERİ



Yüksek hız çeliği

KULLANIM ALANI

- Alaşimsız çelikler (180 HB)
- Yapı çelikleri (Sertlik:24 Hrc)
- Sementasyon nitrasyon çelikleri (Sertlik:27,1 Hrc)
- Dökme demir (Max.240 HB)
- Dökme demir (Min.240 HB)
- Bakır ve alaşımları(Sertlik:22,2 Hrc)

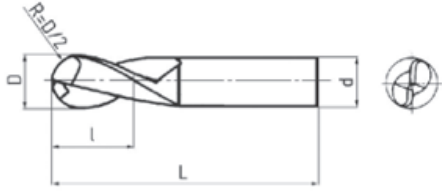
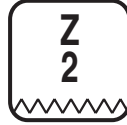
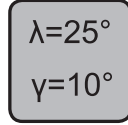

İKİ AĞIZLI UZUN KÜRESEL FREZE				C224
				HSS
D k10	I	L	d h6	FİYAT USD
3	11	63	6	
4	11	63	6	
5	13	68	6	
6	13	68	6	
7	16	80	10	
8	19	88	10	
9	19	88	10	
10	22	95	10	
11	22	102	12	
12	26	110	12	
13	26	110	12	
14	26	110	12	
15	26	110	12	
16	32	123	16	
17	32	123	16	
18	32	123	16	
19	38	141	20	
20	38	141	20	
22	38	141	20	
24	45	166	25	
25	45	166	25	
TEKNİK ÖZELLİKLERİ				HSS
				DIN 1835A
Yüksek hız çeliği		KULLANIM ALANI		<ul style="list-style-type: none"> • Alaşımsız çelikler (180 HB) • Yapı çelikleri (Sertlik:24 Hrc) • Sementasyon nitrasyon çelikleri (Sertlik:27,1 Hrc) • Dökme demir (Max.240 HB) • Dökme demir (Min.240 HB) • Bakır ve alaşımları(Sertlik:22,2 Hrc)

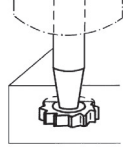
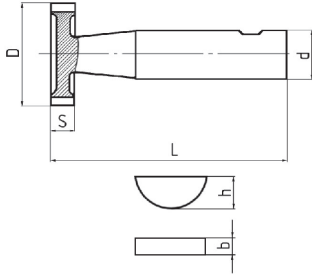
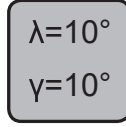
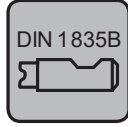

T-YARIK FREZE ÇAPRAZ DİŞLİ DIN850

C320015

D h12	S e 8	L	d h6	Z	bxh DIN 6888	FİYAT USD
10,5	2	50	12	6	2x3,7	
10,5	2,5	50	12	6	2,5x3,7	
10,5	3	50	12	6	3x3,7	
13,5	2	56	12	6	-	
13,5	3	56	12	6	3x5	
13,5	4	56	12	6	4x5	
16,5	2	56	12	6	3x6,5	
16,5	3	56	12	6	3x6,5	
16,5	4	56	12	6	4x6,5	
16,5	5	56	12	6	5x6,5	
19,5	3	56	12	8	-	
19,5	4	56	12	8	4x7,5	
19,5	5	56	12	8	5x7,5	
19,5	6	56	12	8	6x7,5	
22,5	4	56	12	8	-	
22,5	5	63	12	8	5x9	
22,5	6	63	12	8	6x9	
22,5	8	63	12	8	8x9	
25,5	5	63	12	10	-	
25,5	6	63	12	10	6x10	
28,5	6	63	12	10	6x11	
28,5	8	63	12	10	8x11	
28,5	10	71	12	10	10x11	
32,5	6	71	12	10	-	
32,5	7	71	12	10	-	
32,5	8	71	12	10	8x13	
32,5	10	71	12	10	10x13	
38,5	8	71	12	10	-	
45,5	8	71	12	12	-	
45,5	10	71	12	12	10x16	

HSS → Yüksek hız çeliği

KULLANIM ALANI

- 800 N/mm² mukavemetindeki alaşımli dövme çelikler
- Takım çelikleri
- Döküm alaşımli matzemeler
- Kama yuvalarının açılmasında

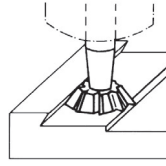
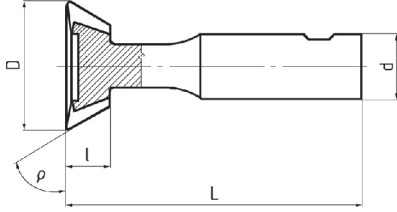
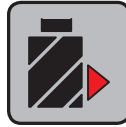
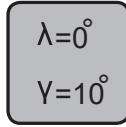
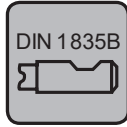

KIRLANGIÇ FREZE DIN 1833A

C3302A

p ±30'	D js 16	l js 14	L	d h6	Z	FİYAT USD
45°	16	4	60	12	10	
45°	20	5	63	12	10	
45°	25	6,3	67	12	10	
45°	32	8	71	16	12	
60°	16	6,3	60	12	10	
60°	20	8	63	12	10	
60°	25	10	67	12	10	
60°	32	12,5	71	16	12	

HSS → Yüksek hız çeliği

KULLANIM ALANI

- 45° ve 60°lik kırılmalı kuyruğu kanallarının frezelenmesi için
- 800 N/mm² mukavemetindeki çelikler
- Takım çelikleri
- Gri döküm alaşımlı malzemeler
- NE- metaller

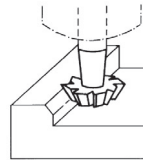
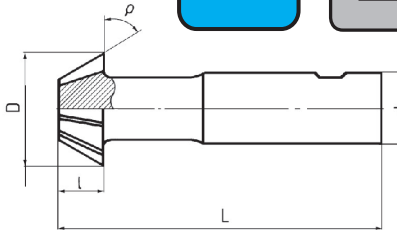
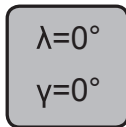

KIRLANGIÇ FREZE DIN 1833B

C3500B

p ±30'	D js 16	l js 14	L	d h6	Z	FİYAT USD
45°	16	4	60	12	10	
45°	20	5	63	12	10	
45°	25	6,3	67	12	10	
45°	32	8	71	16	12	
60°	16	6,3	60	12	10	
60°	20	8	63	12	10	
60°	25	10	67	12	10	
60°	32	12,5	71	16	12	

HSS → Yüksek hız çeliği

KULLANIM ALANI

- 45° ve 60°lik kırılmalı kuyruğu kanallarının frezelenmesi için
- 800 N/mm² mukavemetindeki çelikler
- Takım çelikleri
- Gri döküm alaşımlı malzemeler
- NE- metaller

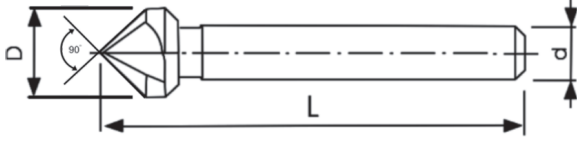
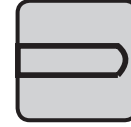
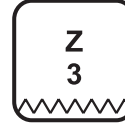
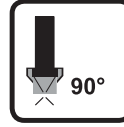

HSS



KARBÜR

HAVAŞA FREZE 90° DIN 335/C 3 AĞIZLI			C.335 HSS	C.333 KARBÜR
D	d	L	FİYAT USD	FİYAT USD
6	5	45		
8	6	46/50		
8,3	6	46/50		
10	6	46/50		
10,4	6	46/50		
11,5	8	56		
12	8	46/54		
12,4	8	54		
16	8	46,5/60		
16,5	10	60		
20	10	47/63		
20,5	10	63		
23	10	67		
25	10	51/66		
25,5	10	66		
30	12	71		
31	12	71		
31,5	12	71		
35	12	80		
40	13	80		
50	13	85		
Yüksek hız çeliği			KULLANIM ALANI	<ul style="list-style-type: none"> • Demir ve demir dışı metallerde • Yumuşak malzemelerde • Delme işlemlerinde • Havaşalama işlemlerinde
			<ul style="list-style-type: none"> • Demir ve demir dışı metallerde • Sert malzemelerde (45Hrc) • Delme işlemlerinde • Havaşalama işlemlerinde 	

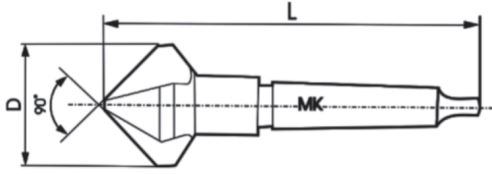

HAVŞA FREZE, KONİK SAPLI 90° DIN 335/D ÜÇ AĞIZLI			C.335MK
D	MK	L	FİYAT USD
30	2	113	
34	2	118	
40	3	140	
50	3	150	
65	4	180	
80	4	190	
<p>HSS → Yüksek hız çeliği</p>			<p>KULLANIM ALANI</p> <ul style="list-style-type: none"> • Demir ve demir dışı metallerde • Yumuşak malzemelerde • Delme işlemlerinde • Havşalama işlemlerinde

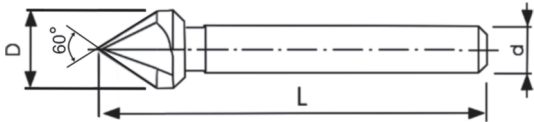

HAVŞA FREZE 60° DIN 334/C ÜÇ AĞIZLI			C.334
D	d	L	FİYAT USD
6,3	5	45	
8	8	50	
10	8	56	
12	8	56	
12,5	8	56	
16	10	63	
20	10	67	
25	12	71	
30	12	84	
31,5	12	84	
35	12	90	
40	12	97	
<p>HSS → Yüksek hız çeliği</p>			<p>KULLANIM ALANI</p> <ul style="list-style-type: none"> • Demir ve demir dışı metallerde • Yumuşak malzemelerde • Delme işlemlerinde • Havşalama işlemlerinde

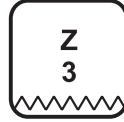
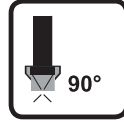

HAVAŞA FREZE SET 6 PARÇA HSS 90° DIN 335/C ÜÇ AĞIZLI

KOD	ÖLÇÜ	FİYAT USD
C.335SET6	6,3-8,3-10,4-12,4-16,5-20,5 mm	



HAVAŞA FREZE SET 6 PARÇA HSS 90° DIN 335/C ÜÇ AĞIZLI SAP 1/4"

KOD	ÖLÇÜ	FİYAT USD
C.335SET1/4	6,3-8,3-10,4-12,4-16,5-20,5 mm	



HAVAŞA FREZE SET 6 PARÇA HSS 90° DIN 335/C ÜÇ AĞIZLI BOY 100 MM

KOD	ÖLÇÜ	FİYAT USD
C.335SET100	6,3-8,3-10,4-12,4-16,5-20,5 mm	

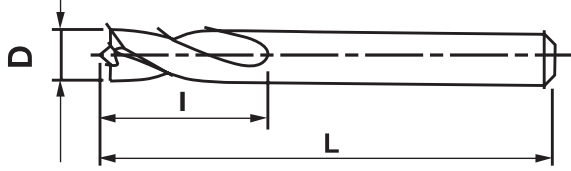

KISA



UZUN

PUNTA ÇÜRÜTME MATKABI HSS CO5 DIN1412E			C1412	C1412 TİN
D (h8 mm)	L (mm)	l (mm)	FİYAT USD	FİYAT USD
6,00	44	23		
6,00	93	57		
8,00	44	23		
8,00	117	75		

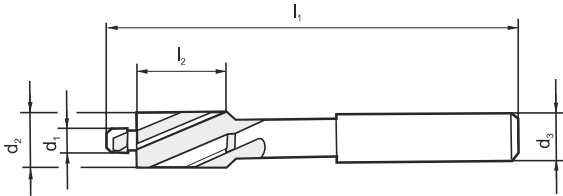
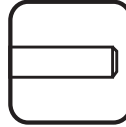
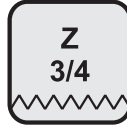

SABİT PİLOTLU HAVŞA FREZE DIN373 HSS						C373
ÇİVATA	d ₂ (mm)	d ₁ (mm)	d ₃ (mm)	l ₁ (mm)	l ₂ (mm)	FİYAT USD
M3	6	3,2	5	71	14	
M4	8	4,3	5	71	14	
M5	10	5,3	8	80	18	
M6	11	6,4	8	80	18	
M8	15	8,4	12,5	100	22	
M10	18	10,5	12,5	100	22	
M12	20	13,0	12,5	100	22	
M14	24	15,0	12,5	100	22	
M16	26	17,0	12,5	100	22	
M18	30	19,0	12,5	100	22	
M20	33	20,0	12,5	100	22	

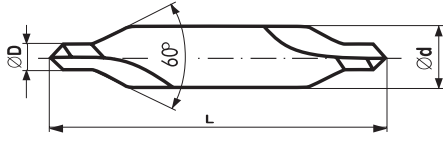
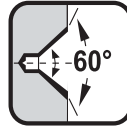

PUNTA MATKABI DIN 333A HSS			C150
D (mm)	L (mm)	d (mm)	FİYAT USD
1,00	31,5	3,15	
1,25	31,5	3,15	
1,60	35,5	4,00	
2,00	40,0	5,00	
2,50	45,0	6,30	
3,15	50,0	8,00	
4,00	56,0	10,00	
5,00	63,0	12,50	
6,30	71,0	16,00	
8,00	80,0	20,00	
10,00	106,0	25,00	

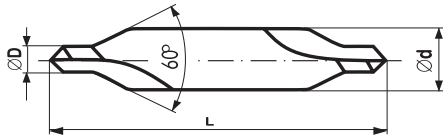
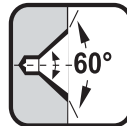
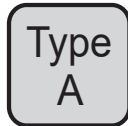

UZUN PUNTA MATKABI DIN 333A HSS			C151
D (mm)	L (mm)	d (mm)	FİYAT USD
2,00	76,0	5,00	
2,50	102,0	6,30	
3,15	102,0	8,00	
4,00	127,0	10,00	
5,00	127,0	12,50	
6,30	127,0	16,00	

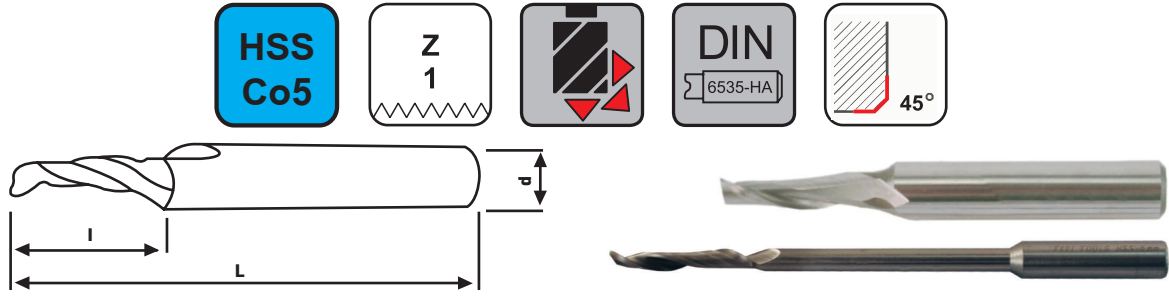

TEK AĞIZLI ALÜMİNYUM FREZESİ				CTM135
D	d	l	L	FİYAT USD
3	6	12	80	
3	8	30	80	
4	6	14	80	
4	8	14	60	
4	8	14	80	
5	6	14	80	
5	8	14	60	
5	8	18	80	
5	8	40	100	
5	8	35	120	
5	8	50	120	
6	6	14	80	
6	8	14	60	
6	8	18	80	
6	8	25	100	
8	8	14	80	
8	8	25	100	
8	8	25	120	

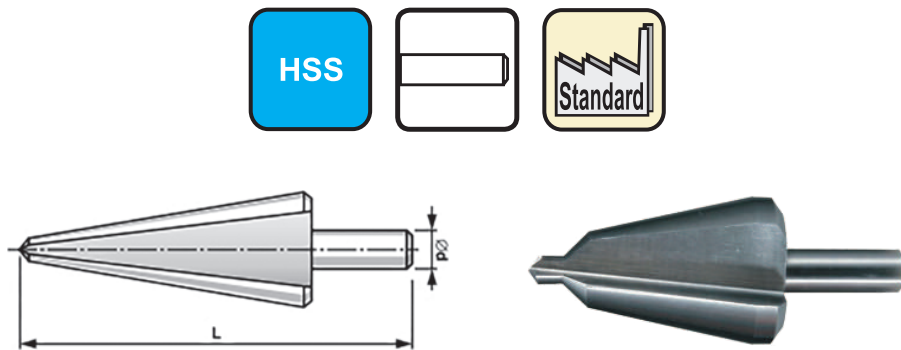

KADEMESİZ SAC DELME MATKABI HSS			C338
EBAT	L (mm)	d (mm)	FİYAT USD
3-16mm	58	6	
5-20mm	66	8	
16-30mm	75	10	

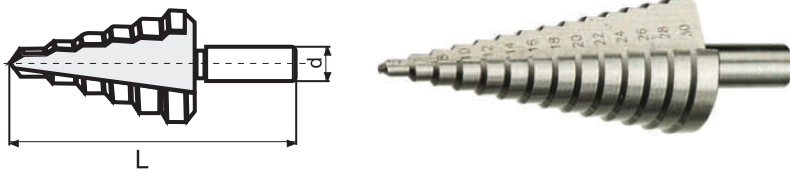
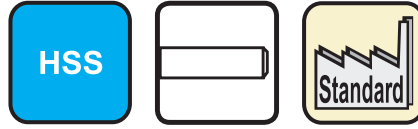

KADEMELİ SAC DELME MATKABI HSS				C339
EBAT	L (mm)	d (mm)	KADEME ÖLÇÜLERİ (mm)	FİYAT USD
4-20mm x 2mm	76	8	4-6-8-10-12-16-18-20	
5-35mm x 2-3mm	100	13	5-8-10-12-15-18-20-22-25-27-30-32-35	
4-39mm x 2-3mm	107	13	4-6-9-12-15-18-21-24-27-30-33-36-39	

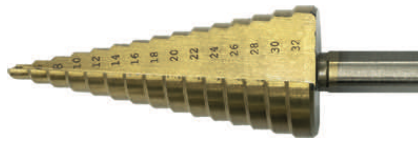
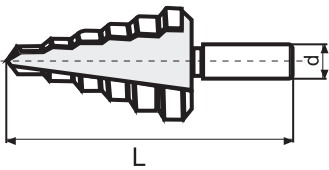
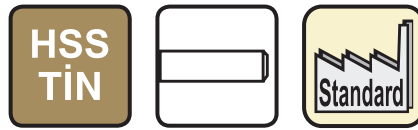

C339-SET

KADEMELİ SAC DELME MATKABI HSS				C339
EBAT	L (mm)	d (mm)	KADEME ÖLÇÜLERİ (mm)	FİYAT USD
4-12mm x 2mm	64	6	4-6-8-10-12	
4-20mm x 2mm	70	8	4-6-8-10-12-16-18-20	
4-32mm x 2mm	100	10	4-6-8-10-12-16-18-20-22-24-26-28-30-32	
6-52mm x 4mm	100	10	6-12-16-20-24-28-32-36-40-44-48-52	
KOD	SET İÇERİĞİ (mm)			FİYAT USD
C339-SET	4-12 / 4-20 / 4-32			

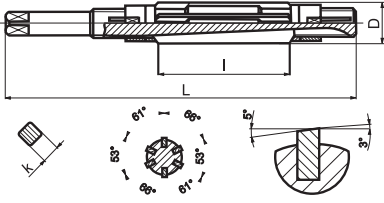

AYARLI KOVANSIZ EL RAYBASI						C.859
ÖLÇÜ (mm)	D (mm)	L (mm)	l (mm)	k (mm)	BIÇAK AD.	FİYAT USD
7,00-8,00	6	91	25	3	4	
8,00-8,70	7	96	30	3,5	4	
8,70-9,50	8	101	35	4	4	
9,50-10,25	9	106	40	5	4	
10,25-11,00	9,5	115	40	5	6	
11,00-12,00	10	118	40	5	6	
12,00-13,50	11	126	40	5	6	
13,50-15,00	12	142	45	6	6	
15,00-16,50	13	150	50	7	6	
16,50-18,25	15	157	55	8	6	
18,25-19,75	16	160	57	8	6	
19,75-21,50	18	162	57	9	6	
21,50-23,75	20	190	68	10	6	
23,75-27,00	22	200	68	12	6	
27,00-30,00	24	210	70	14	6	
30,00-34,00	28	246	85	16	6	
34,00-38,75	32	292	100	18	6	
38,75-46,00	38	311	100	22	6	
46,00-56,00	42	333	105	24	6	



11 PARÇA AYARLI KOVANSIZ RAYBA SETİ		
KOD	EBAT	FİYAT USD
C.859SET	12,00-38,75 mm	

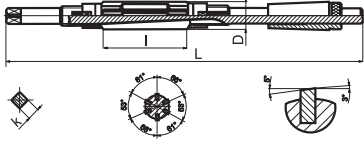













AYARLI KOVANLI EL RAYBASI						C.859K
ÖLÇÜ (mm)	D (mm)	L (mm)	l (mm)	k (mm)	BIÇAK AD.	FİYAT USD
7,00-8,00	6	140	25	3	4	
8,00-8,70	7	150	30	3,5	4	
8,70-9,50	8	160	35	4	4	
9,50-10,25	9	165	40	5	4	
10,25-11,00	9,5	170	40	5	6	
11,00-12,00	10	180	40	5	6	
12,00-13,50	11	185	40	5	6	
13,50-15,00	12	190	45	6	6	
15,00-16,50	13	220	50	7	6	
16,50-18,25	15	245	55	8	6	
18,25-19,75	16	247	57	8	6	
19,75-21,50	18	255	57	9	6	
21,50-23,75	20	295	68	10	6	
23,75-27,00	22	315	68	12	6	
27,00-30,00	24	335	70	14	6	
30,00-34,00	28	375	85	16	6	
34,00-38,75	32	405	100	18	6	
38,75-46,00	38	425	100	22	6	
46,00-56,00	42	425	105	24	6	



11 PARÇA AYARLI KOVANLI RAYBA SETİ		
KOD	EBAT	FİYAT USD
C.860.KOV.SET	12,00-38,75 mm	

EKONOMİK TİP SERT METAL (KARBÜR) KALIPÇI FREZELER

	TİP NO	KOD	ÇAP (mm)	KES.BOY (mm)	SAP (mm)	TAM BOY (mm)	FİYAT USD		TİP NO	KOD	ÇAP (mm)	KES.BOY (mm)	SAP (mm)	TAM BOY (mm)	FİYAT USD
	SA-43M-DC	C175-A0313X03	3	13	3	38			SH-41M-DC	C175-H0307X03	3	7	3	38	
	SA-1M-DC	C175-A0616X06	6	16	6	56			SH-1M-DC	C175-H0618X06	6	18	6	58	
	SA-2M-DC	C175-A0820X06	8	20	6	60			SH-2M-DC	C175-H0820X06	8	20	6	60	
	SA-3M-DC	C175-A1020X06	10	20	6	60			SH-3M-DC	C175-H1025X06	10	25	6	65	
	SA-5M-DC	C175-A1225X06	12	25	6	65			SH-5M-DC	C175-H1232X06	12	32	6	72	
	SA-6M-DC	C175-A1625X06	16	25	6	65			SH-6M-DC	C175-H1636X06	16	36	6	76	
	SB-43M-DC	C175-B0313X03	3	13	3	38			SJ-42M-DC	C175-J0302X03	3	2	3	42	
	SB-1M-DC	C175-B0616X06	6	16	6	56			SJ-1M-DC	C175-J0605X06	6	5	6	48	
	SB-2M-DC	C175-B0820X06	8	20	6	60			SJ-2M-DC	C175-J0807X06	8	7	6	47	
	SB-3M-DC	C175-B1020X06	10	20	6	60			SJ-3M-DC	C175-J1008X06	10	8	6	52	
	SB-5M-DC	C175-B1225X06	12	25	6	65			SJ-5M-DC	C175-J1210X06	12	10	6	54	
	SB-6M-DC	C175-B1625X06	16	25	6	65			SJ-6M-DC	C175-J1613X06	16	13	6	56	
	SC-42M-DC	C175-C0313X03	3	13	3	38			SK-42M-DC	C175-K0301X03	3	1	3	42	
	SC-1M-DC	C175-C0616X06	6	16	6	56			SK-1M-DC	C175-K0603X06	6	3	6	45	
	SC-2M-DC	C175-C0820X06	8	20	6	60			SK-2M-DC	C175-K0804X06	8	4	6	47	
	SC-3M-DC	C175-C1020X06	10	20	6	60			SK-3M-DC	C175-K1005X06	10	5	6	48	
	SC-5M-DC	C175-C1225X06	12	25	6	65			SK-5M-DC	C175-K1206X06	12	6	6	48	
	SC-6M-DC	C175-C1625X06	16	25	6	65			SK-6M-DC	C175-K1608X06	16	8	6	50	
	SD-42M-DC	C175-D0302X03	3	2	3	38			SL-42M-DC	C175-L0313X03	3	13	3	38	
	SD-1M-DC	C175-D0605X06	6	5	6	45			SL-1M-DC	C175-L0616X06	6	16	6	56	
	SD-2M-DC	C175-D0807X06	8	7	6	47			SL-2M-DC	C175-L0822X06	8	22	6	62	
	SD-3M-DC	C175-D1009X06	10	9	6	49			SL-3M-DC	C175-L1025X06	10	25	6	65	
	SD-5M-DC	C175-D1210X06	12	10	6	51			SL-5M-DC	C175-L1228X06	12	28	6	68	
	SD-6M-DC	C175-D1614X06	16	14	6	54			SL-6M-DC	C175-L1633X06	16	33	6	73	
	SE-41M-DC	C175-E0307X03	3	7	3	38			SM-42M-DC	C175-M0311X03	3	11	3	38	
	SE-1M-DC	C175-E0610X06	6	10	6	50			SM-1M-DC	C175-M0618X06	6	18	6	58	
	SE-2M-DC	C175-E0813X06	8	13	6	53			SM-2M-DC	C175-M0820X06	8	20	6	65	
	SE-3M-DC	C175-E1016X06	10	16	6	56			SM-3M-DC	C175-M1020X06	10	20	6	60	
	SE-5M-DC	C175-E1220X06	12	20	6	60			SM-5M-DC	C175-M1225X06	12	25	6	65	
	SE-6M-DC	C175-E1625X06	16	25	6	65			SM-6M-DC	C175-M1625X06	16	25	6	65	
	SF-42M-DC	C175-F0313X03	3	13	3	38			SN-42M-DC	C175-N0307X03	3	7	3	38	
	SF-1M-DC	C175-F0618X06	6	18	6	58			SN-1M-DC	C175-N0607X06	6	7	6	47	
	SF-2M-DC	C175-F0820X06	8	20	6	65			SN-2M-DC	C175-N0807X06	8	7	6	50	
	SF-3M-DC	C175-F1020X06	10	20	6	60			SN-3M-DC	C175-N1010X06	10	10	6	55	
	SF-5M-DC	C175-F1225X06	12	25	6	65			SN-4M-DC	C175-N1213X06	12	13	6	53	
	SF-6M-DC	C175-F1625X06	16	25	6	70			SN-6M-DC	C175-N1613X06	16	13	6	58	
	SG-43M-DC	C175-G0313X03	3	13	3	38									
	SG-1M-DC	C175-G0618X06	6	18	6	58									
	SG-2M-DC	C175-G0820X06	8	20	6	65									
	SG-3M-DC	C175-G1020X06	10	20	6	60									
	SG-5M-DC	C175-G1225X06	12	25	6	65									
	SG-6M-DC	C175-G1625X06	16	25	6	70									

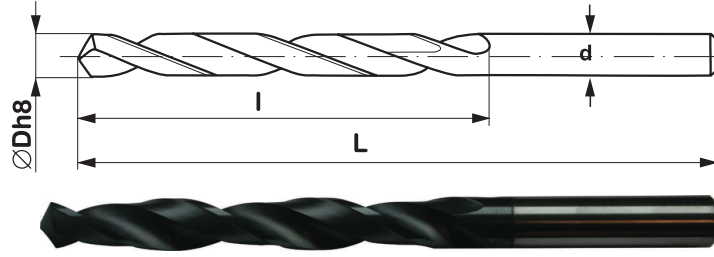
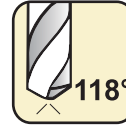
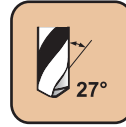
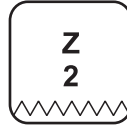

KOD	D	l	d	L	FİYAT USD
C45-020	2	12	2	38	
C45-021	2,1	13	2,1	40	
C45-022	2,2	13	2,2	40	
C45-023	2,3	13	2,3	40	
C45-024	2,4	14	2,4	43	
C45-025	2,5	14	2,5	43	
C45-026	2,6	16	2,6	46	
C45-027	2,7	16	2,7	46	
C45-028	2,8	16	2,8	46	
C45-029	2,9	16	2,9	46	
C45-030	3	16	3	46	
C45-031	3,1	18	3,1	49	
C45-032	3,2	18	3,2	49	
C45-033	3,3	18	3,3	49	
C45-034	3,4	20	3,4	52	
C45-035	3,5	20	3,5	52	
C45-036	3,6	20	3,6	52	
C45-037	3,7	20	3,7	52	
C45-038	3,8	22	3,8	55	
C45-039	3,9	22	3,9	55	
C45-040	4	22	4	55	
C45-041	4,1	22	4,1	55	
C45-042	4,2	22	4,2	55	
C45-043	4,3	24	4,3	58	
C45-044	4,4	24	4,4	58	
C45-045	4,5	24	4,5	58	
C45-046	4,6	24	4,6	58	
C45-047	4,7	26	4,7	62	
C45-048	4,8	26	4,8	62	
C45-049	4,9	26	4,9	62	
C45-050	5	26	5	62	
C45-051	5,1	26	5,1	62	
C45-052	5,2	26	5,2	62	
C45-053	5,3	26	5,3	62	
C45-054	5,4	28	5,4	66	
C45-055	5,5	28	5,5	66	
C45-057	5,7	28	5,7	66	
C45-058	5,8	28	5,8	66	
C45-059	5,9	28	5,9	66	
C45-060	6	28	6	66	
C45-061	6,1	31	6,1	70	
C45-062	6,2	31	6,2	70	
C45-063	6,3	31	6,3	70	
C45-064	6,4	31	6,4	70	
C45-065	6,5	31	6,5	70	
C45-066	6,6	31	6,6	70	

KOD	D	l	d	L	FİYAT USD
C45-067	6,7	31	6,7	70	
C45-068	6,8	31	6,8	70	
C45-069	6,9	31	6,9	70	
C45-070	7	34	7	74	
C45-071	7,1	34	7,1	74	
C45-072	7,2	34	7,2	74	
C45-073	7,3	34	7,3	74	
C45-074	7,4	34	7,4	74	
C45-075	7,5	34	7,5	74	
C45-076	7,6	37	7,6	79	
C45-077	7,7	37	7,7	79	
C45-078	7,8	37	7,8	79	
C45-079	7,9	37	7,9	79	
C45-080	8	37	8	79	
C45-081	8,1	37	8,1	79	
C45-082	8,2	37	8,2	79	
C45-083	8,3	37	8,3	79	
C45-084	8,4	37	8,4	79	
C45-085	8,5	37	8,5	79	
C45-086	8,6	40	8,6	84	
C45-087	8,7	40	8,7	84	
C45-088	8,8	40	8,8	84	
C45-089	8,9	40	8,9	84	
C45-090	9	40	9	84	
C45-095	9,5	40	9,5	84	
C45-100	10	43	10	89	
C45-102	10,2	43	10,2	89	
C45-105	10,5	43	10,5	89	
C45-110	11	47	11	95	
C45-115	11,5	47	11,5	95	
C45-120	12	51	12	102	
C45-125	12,5	51	12,5	102	
C45-130	13	51	13	102	
C45-140	14	54	14	107	
C45-145	14,5	54	14,5	107	
C45-150	15	56	15	111	
C45-160	16	58	16	115	
C45-165	16,5	58	16,5	115	
C45-170	17	60	17	117	
C45-175	17,5	62	17,5	123	
C45-180	18	62	18	123	
C45-185	18,5	64	18,5	127	
C45-190	19	64	19	127	
C45-195	19,5	64	19,5	127	
C45-200	20	66	20	131	

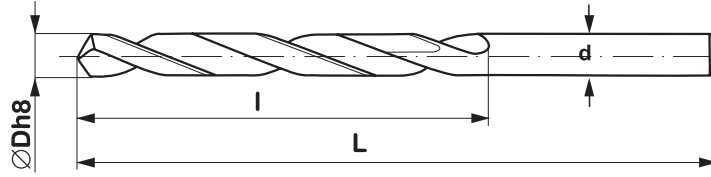
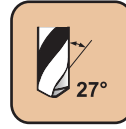
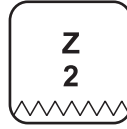

KOD	D	l	d	L	FİYAT USD
C47-020	2	24	2	49	
C47-021	2,1	24	2,1	49	
C47-022	2,2	27	2,2	53	
C47-023	2,3	27	2,3	53	
C47-024	2,4	30	2,4	57	
C47-025	2,5	30	2,5	57	
C47-026	2,6	30	2,6	57	
C47-027	2,7	33	2,7	61	
C47-028	2,8	33	2,8	61	
C47-029	2,9	33	2,9	61	
C47-030	3	33	3	61	
C47-031	3,1	36	3,1	65	
C47-032	3,2	36	3,2	65	
C47-033	3,3	36	3,3	65	
C47-034	3,4	39	3,4	70	
C47-035	3,5	39	3,5	70	
C47-036	3,6	39	3,6	70	
C47-037	3,7	39	3,7	70	
C47-038	3,8	43	3,8	75	
C47-039	3,9	43	3,9	75	
C47-040	4	43	4	75	
C47-041	4,1	43	4,1	75	
C47-042	4,2	43	4,2	75	
C47-043	4,3	47	4,3	80	
C47-044	4,4	47	4,4	80	
C47-045	4,5	47	4,5	80	
C47-046	4,6	47	4,6	80	
C47-047	4,7	47	4,7	80	
C47-048	4,8	52	4,8	86	
C47-049	4,9	52	4,9	86	
C47-050	5	52	5	86	
C47-051	5,1	52	5,1	86	
C47-052	5,2	52	5,2	86	
C47-053	5,3	52	5,3	86	
C47-054	5,4	57	5,4	93	
C47-055	5,5	57	5,5	93	
C47-056	5,6	57	5,6	93	
C47-057	5,7	57	5,7	93	
C47-058	5,8	57	5,8	93	
C47-059	5,9	57	5,9	93	
C47-060	6	57	6	93	
C47-061	6,1	63	6,1	101	
C47-062	6,2	63	6,2	101	
C47-063	6,3	63	6,3	101	
C47-064	6,4	63	6,4	101	
C47-065	6,5	63	6,5	101	
C47-066	6,6	63	6,6	101	
C47-067	6,7	63	6,7	101	
C47-068	6,8	69	6,8	109	
C47-069	6,9	69	6,9	109	
C47-070	7	69	7	109	

KOD	D	l	d	L	FİYAT USD
C47-071	7,1	69	7,1	109	
C47-072	7,2	69	7,2	109	
C47-073	7,3	69	7,3	109	
C47-074	7,4	69	7,4	109	
C47-075	7,5	69	7,5	109	
C47-076	7,6	69	7,6	109	
C47-077	7,7	75	7,7	117	
C47-078	7,8	75	7,8	117	
C47-079	7,9	75	7,9	117	
C47-080	8	75	8	117	
C47-081	8,1	75	8,1	117	
C47-082	8,2	75	8,2	117	
C47-083	8,3	75	8,3	117	
C47-084	8,4	75	8,4	117	
C47-085	8,5	75	8,5	117	
C47-086	8,6	81	8,6	125	
C47-087	8,7	81	8,7	125	
C47-088	8,8	81	8,8	125	
C47-089	8,9	81	8,9	125	
C47-090	9	81	9	125	
C47-091	9,1	81	9,1	125	
C47-092	9,2	81	9,2	125	
C47-093	9,3	81	9,3	125	
C47-094	9,4	81	9,4	125	
C47-095	9,5	81	9,5	125	
C47-096	9,6	81	9,6	125	
C47-097	9,7	81	9,7	125	
C47-098	9,8	87	9,8	133	
C47-099	9,9	87	9,9	133	
C47-100	10	87	10	133	
C47-101	10,1	87	10,1	133	
C47-102	10,2	87	10,2	133	
C47-103	10,3	87	10,3	133	
C47-104	10,4	87	10,4	133	
C47-105	10,5	87	10,5	133	
C47-106	10,6	94	10,6	142	
C47-107	10,7	94	10,7	142	
C47-108	10,8	94	10,8	142	
C47-109	10,9	94	10,9	142	
C47-110	11	94	11	142	
C47-115	11,5	94	11,5	142	
C47-120	12	101	12	151	
C47-125	12,5	101	12,5	151	
C47-130	13	101	13	151	
C47-135	13,5	101	13,5	151	
C47-140	14	120	14	175	
C47-145	14,5	120	14,5	175	
C47-150	15	120	15	175	
C47-160	16	120	16	175	
C47-180	18	120	18	175	

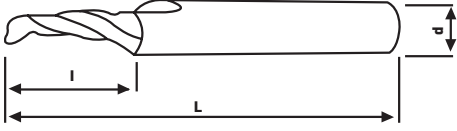
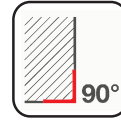
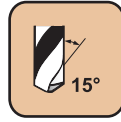
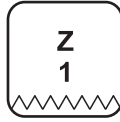

Alüminyum ve Sert Plastik İçin

KOD	Ø	l	d	L	FİYAT USD
C901-1101	3	8	3	60	
C901-1102	3	8	8	60	
C901-1103	3	8	3	90	
C901-1111	4	12	4	60	
C901-1112	4	12	8	60	
C901-1113	4	12	4	90	
C901-1121	5	16	5	60	
C901-1122	5	16	8	60	
C901-1123	5	16	5	90	
C901-1131	6	20	6	60	
C901-1132	6	20	8	60	
C901-1133	6	20	6	90	
C901-1141	8	25	8	60	
C901-1143	8	25	8	90	

SERT METAL (KARBÜR) FREZELERİN KULLANIM DEĞERLERİ

MALZEME	DEVİR SAYISI (RPM)									
	İlerleme (m/dakika)		6,5 mm'e kadar		6,5 - 12,5 mm		12,6 - 19 mm		19,1 - 25 mm	
Alüminyum / Alaşımları	183	366	9168	17912	8956	9295	4620	6128	3048	4657
Bronz / Pirinç	91	168	4584	8210	4478	4269	2310	2809	1524	2135
Bakır / Alaşımları	152	274	7640	13435	7463	6986	3850	4596	2540	3493
Demir Döküm (Yumuşak ± 195 bhn)	61	152	3056	7464	2985	3881	1540	2553	1016	1941
Demir Döküm (Orta ± 255 bhn)	38	107	1910	5225	1866	2717	963	1787	635	1358
Demir Döküm (Sert ± 275 bhn)	24	91	1222	4478	1194	2329	616	1532	406	1164
Magnezyum	244	427	12224	20898	11942	10867	6161	7149	4064	5436
Krom Nikel Alaşımları	20	53	993	2612	970	1358	500	894	330	679
Plastikler	183	366	9168	17913	8956	9315	4620	6128	3048	4657
Sıcak İş Çelikleri (35-40 Rc)	46	107	2292	5225	2239	2717	1155	1787	762	1358
Sıcak İş Çelikleri (40-45 Rc)	38	84	1910	4105	1866	2135	963	1404	635	1067
Sıcak İş Çelikleri (45+ Rc)	15	61	764	2985	746	1552	385	1021	254	776
Çelik - Karbon	53	107	2674	5225	2612	2717	1348	1787	889	1358
Çelik - Kalıp	15	76	764	3732	746	1941	385	1277	254	970
Çelik - T akım	46	76	2292	3732	2239	1941	1155	1277	762	970
Paslanmaz Çelik - Yumuşak	76	122	3820	5971	3731	3105	1925	2043	770	1552
Paslanmaz Çelik - Sert	23	76	1146	3732	1119	1941	578	1277	381	970
Titanyum Alaşımları	27	63	1375	3359	1343	1747	693	1149	457	873

ELLE SIKMALI MANDRENLER

TİP 500

ÖZELLİKLER

- MATKAP UÇLARININ SERİ OLARAK BAĞLANMASI VE YİNE AYNI ŞEKİLDE SÖKÜLMESİ İÇİN UYGUNDUR.
- ÇALIŞMA ESNASINDA AYAKLARDA OLUŞAN MOMENT OTOMATİK OLARAK SIKMA KUVVETİNİ ARTTIRIR.



KOD	SIKMA KAPASİTESİ (mm)	BAĞLANTI TİPİ	DIŞ ÇAP (mm)	KAPALI BOY (mm)	AÇIK BOY (mm)	SIKMA MOMENTİ Nm	MAX. SALGI (mm)	FİYAT USD
510	0-10	B12	35	78	71	9	0,07	
503	0-10	3/8-24	35	78	71	9	0,07	
501	0-10	1/2-20	35	78	71	9	0,07	
513	1-13	B16	42	96	87	12	0,07	
533	1-13	3/8-24	42	96	87	12	0,07	
531	1-13	1/2-20	42	96	87	12	0,07	
515	1-16	B16	49	112	103	14	0,07	
516	1-16	B18	49	112	103	14	0,07	
561	1-16	1/2-20	49	112	103	14	0,07	
565	1-16	5/8-16	49	112	103	14	0,07	
520	5-20	B22	55	131	122	15	0,07	

ANAHTARLI MANDRENLER

TİP 600

ÖZELLİKLER

- ENDÜSTRİYEL HİZMET İÇİN BELİRLENEN STANDART ÖLÇÜLERDEDİR.
- SAĞ VE SOL YÖNLÜ OLARAK EMNİYETLE KULLANILABİLİR.
- ANAHTARI İLE BİRLİKTE TESLİM EDİLİR.



KOD	SIKMA KAPASİTESİ (mm)	BAĞLANTI TİPİ	DIŞ ÇAP (mm)	AÇIK BOY (mm)	KAPALI BOY (mm)	ANAHTAR KODU	FİYAT USD
613	1-13	B16	52	67	90	S1	
615	1-16	B16	56	80	100	S3	
616	1-16	B18	56	80	100	S3	
620	5-20	B22	65	92	114	S4	

MORS KOVANLARI

TİP 7100

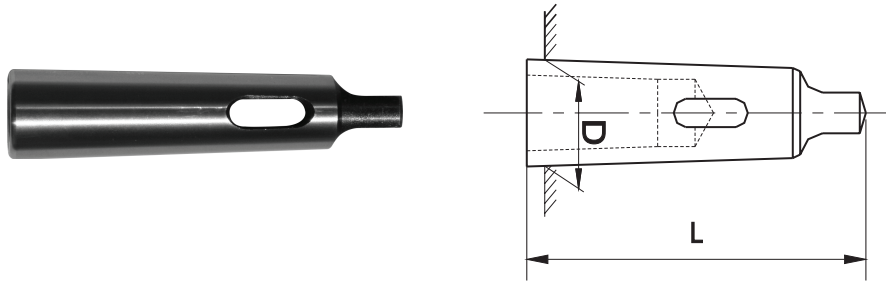

KOD	DIŞ KONİK	İÇ KONİK	D (mm)	İÇ KONİK (mm)	L (mm)	FİYAT USD
7121	MK2	MK1	17,780	12,065	92	
7131	MK3	MK1	23,825	12,065	99	
7132	MK3	MK2	23,825	17,780	112	
7141	MK4	MK1	31,267	12,065	124	
7142	MK4	MK2	31,267	17,780	124	
7143	MK4	MK3	31,267	23,825	140	
7151	MK5	MK1	44,399	12,065	156	
7152	MK5	MK2	44,399	17,780	156	
7153	MK5	MK3	44,399	23,825	156	
7154	MK5	MK4	44,399	31,267	171	
7165	MK6	MK5	63,348	44,399	218	

UZATMA MORS KOVANLARI

TİP 7600

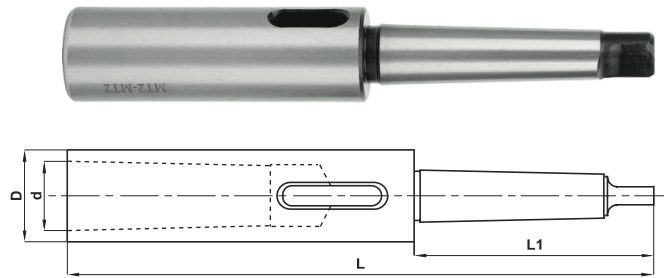

KOD	DIŞ KONİK	İÇ KONİK	D (mm)	d (mm)	L (mm)	L1 (mm)	FİYAT USD
7623	MK2	MK3	32	23,825	196	80	
7632	MK3	MK2	24	17,780	196	100	
7633	MK3	MK3	32	23,825	215	100	
7634	MK3	MK4	45	31,267	240	100	
7643	MK4	MK3	32	23,825	240	125	
7644	MK4	MK4	45	31,267	264	125	
7645	MK4	MK5	63	44,399	300	125	
7654	MK5	MK4	45	31,267	300	156	
7655	MK5	MK5	63	44,399	335	156	

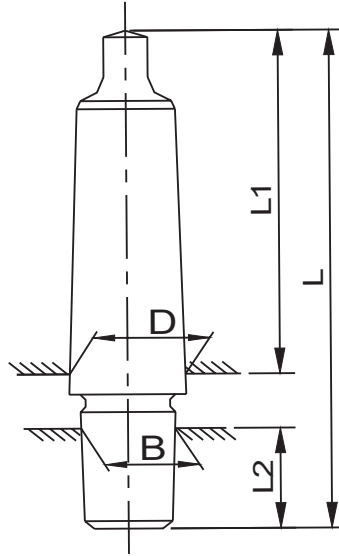

KOD	MK	B		D (mm)	L1 (mm)	L2 (mm)	L (mm)	FİYAT USD
		KONİK	ÖLÇÜ (mm)					
6001	MK1	B10	10,095	12,065	62	14,5	86	
6011	MK1	B12	12,065	12,065	62	18,5	89	
6002	MK2	B10	10,095	17,780	75	14,5	103	
6012	MK2	B12	12,065	17,780	75	18,5	106	
6022	MK2	B16	15,733	17,780	75	24	110	
6032	MK2	B18	17,780	17,780	75	32	117	
6013	MK3	B12	12,065	23,825	94	18,5	125	
6023	MK3	B16	15,733	23,825	94	24	133	
6033	MK3	B18	17,780	23,825	94	32	140	
6043	MK3	B22	21,793	23,825	94	40,5	147	
6053	MK3	B24	23,825	23,825	94	50,5	158	
6024	MK4	B16	15,733	31,267	117,5	24	158	
6034	MK4	B18	17,780	31,267	117,5	32	168	
6044	MK4	B22	21,793	31,267	117,5	40,5	175	
6054	MK4	B24	23,825	31,267	117,5	50,5	185	
6063	MK5	B18	17,780	44,399	149,5	50,5	185	
6064	MK5	B22	21,793	44,399	149,5	50,5	185	
6065	MK5	B24	23,825	44,399	149,5	50,5	185	

MORS KAMALARI

TİP 7200

ÖZELLİKLER

- MORS KOVANLARININ VE MANDREN SAPLARININ BİRBİRLERİNDEN VEYA TEZGAHTAN KOLAYCA SÖKÜLMELERİNİ SAĞLAR
- SERTLİK : 35 ± 2 HRC

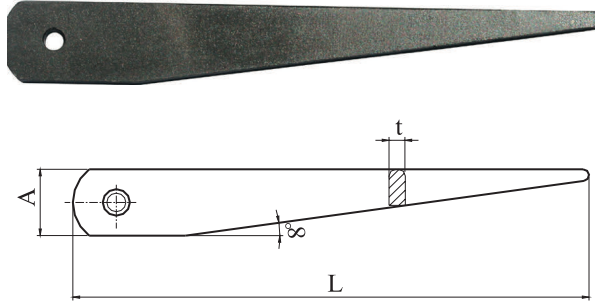

KOD	İLGİLİ KONİK	A (mm)	L (mm)	t (mm)	FİYAT USD
7202	MK1/MK2	20	140	5	
7203	MK3	25	190	7	
7204	MK4	30	225	10	

MONTAJ APARATLARI (DÖKÜM)

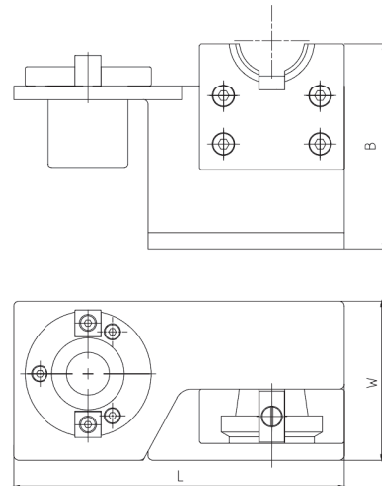

KOD	TİP	l (mm)	W (mm)	B (mm)	AĞIRLIK (Kg)	FİYAT USD
CTM.SK.30	SK 30	205	98,5	128	3,7	
CTM.SK.40	SK 40	205	98,5	128	3,8	
CTM.SK.50	SK 50	275	150	198	11,4	

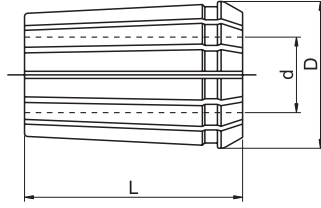

ÖZELLİKLER

- SIKMA KAPASİTESİ : 0,5 mm
- SERTLİK : 45-49 HRC
- SALGI : DIN 6388 / 1.SINIF

462 E PENSLER

D=35,05 mm / L=52 mm

KOD	d (mm)	SIKMA KAPASİTESİ (mm)	FİYAT USD
462E.3	3	3-2,5	
462E.4	4	4-3,5	
462E.5	5	5-4,5	
462E.6	6	6-5,5	
462E.7	7	7-6,5	
462E.8	8	8-7,5	
462E.9	9	9-8,5	
462E.10	10	10-9,5	
462E.11	11	11-10,5	
462E.12	12	12-11,5	
462E.13	13	13-12,5	
462E.14	14	14-13,5	
462E.15	15	15-14,5	
462E.16	16	16-15,5	
462E.17	17	17-16,5	
462E.18	18	18-17,5	
462E.19	19	19-18,5	
462E.20	20	20-19,5	
462E.21	21	21-20,5	
462E.22	22	22-21,5	
462E.23	23	23-22,5	
462E.24	24	24-23,5	
462E.25	25	25-24,5	

467 E PENSLER

D=43,7 mm / L=60 mm

KOD	d (mm)	SIKMA KAPASİTESİ (mm)	FİYAT USD
467E.3	3	3-2,5	
467E.4	4	4-3,5	
467E.5	5	5-4,5	
467E.6	6	6-5,5	
467E.7	7	7-6,5	
467E.8	8	8-7,5	
467E.9	9	9-8,5	
467E.10	10	10-9,5	
467E.11	11	11-10,5	
467E.12	12	12-11,5	
467E.13	13	13-12,5	
467E.14	14	14-13,5	
467E.15	15	15-14,5	
467E.16	16	16-15,5	
467E.17	17	17-16,5	
467E.18	18	18-17,5	
467E.19	19	19-18,5	
467E.20	20	20-19,5	
467E.21	21	21-20,5	
467E.22	22	22-21,5	
467E.23	23	23-22,5	
467E.24	24	24-23,5	
467E.25	25	25-24,5	
467E.26	26	26-25,5	
467E.27	27	27-26,5	
467E.28	28	28-27,5	
467E.29	29	29-28,5	
467E.30	30	30-29,5	
467E.31	31	31-30,5	
467E.32	32	32-31,5	

FİYAT USD

462 E PENS SETİ



SET İÇİNDE 16 ADET PENS VARDIR.

FİYAT USD

467 E PENS SETİ



SET İÇİNDE 16 ADET PENS VARDIR.

4	5	6	7	8	9	10	11
12	14	16	18	20	22	24	25

5	6	7	8	10	12	14	16
18	20	22	24	25	28	30	32

ER PENSLER

DIN 6499-B

ISO 15488

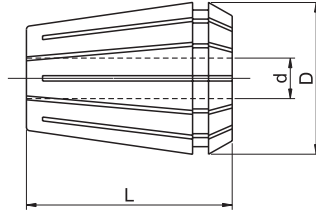

ÖZELLİKLER

- SIKMA KAPASİTESİ : 1 mm
- SERTLİK : 45-49 HRC
- SALGI : DIN 6499 / 1.SINIF

ER 8 PENSLER (4004E)
D=8,5 mm / L=13,6 mm

KOD	d (mm)	SIKMA KAPASİTESİ (mm)	FİYAT USD
ER8.1	1	1	
ER8.1,5	1,5	1,5	
ER8.2	2	2	
ER8.2,5	2,5	2,5	
ER8.3	3	3	
ER8.3,5	3,5	3,5	
ER8.4	4	4	
ER8.4,5	4,5	4,5	
ER8.5	5	5	

ER 11 PENSLER (4008E)
D=11,5 mm / L=18 mm

KOD	d (mm)	SIKMA KAPASİTESİ (mm)	FİYAT USD
ER11.1	1	1-0,5	
ER11.2	2	2-1,5	
ER11.3	3	3-2,5	
ER11.4	4	4-3,5	
ER11.5	5	5-4,5	
ER11.6	6	6-5,5	
ER11.7	7	7-6,5	

ER 16 PENSLER (426E)
D=17 mm / L=27,5 mm

KOD	d (mm)	SIKMA KAPASİTESİ (mm)	FİYAT USD
ER16.2	2	2-1,5	
ER16.3	3	3-2	
ER16.4	4	4-3	
ER16.5	5	5-4	
ER16.6	6	6-5	
ER16.7	7	7-6	
ER16.8	8	8-7	
ER16.9	9	9-8	
ER16.10	10	10-9	

ER 20 PENSLER (428E)
D=21 mm / L=31,5 mm

KOD	d (mm)	SIKMA KAPASİTESİ (mm)	FİYAT USD
ER20.2	2	2-1,5	
ER20.3	3	3-2	
ER20.4	4	4-3	
ER20.5	5	5-4	
ER20.6	6	6-5	
ER20.7	7	7-6	
ER20.8	8	8-7	
ER20.9	9	9-8	
ER20.10	10	10-9	
ER20.11	11	11-10	
ER20.12	12	12-11	
ER20.13	13	13-12	

FİYAT USD	
------------------	--

ER11 PENS SETİ



SET İÇİNDE 7 ADET PENS VARDIR.

1-0,5	2-1,5	3-2,5	4-3,5	5-4,5	6-5,5	7-6,5

FİYAT USD	
------------------	--

ER16 PENS SETİ



SET İÇİNDE 8 ADET PENS VARDIR.

3-2	4-3	5-4	6-5	7-6	8-7	9-8	10-9

FİYAT USD	
------------------	--

ER20 PENS SETİ



SET İÇİNDE 12 ADET PENS VARDIR.

2-1	3-2	4-3	5-4	6-5	7-6
8-7	9-8	10-9	11-10	12-11	13-12

ER PENSLER

DIN 6499-B

ISO 15488

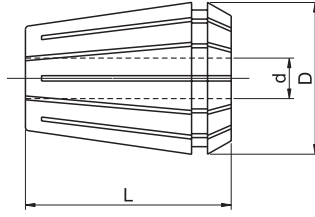

ÖZELLİKLER

- SIKMA KAPASİTESİ : 1 mm
- SERTLİK : 45-49 HRC
- SALGI : DIN 6499 / 1.SINIF

ER 25 PENSLER (430E)	ER 32 PENSLER (470E)	ER 40 PENSLER (472E)
D=26 mm / L=34 mm	D=33 mm / L=40 mm	D=41 mm / L=46 mm

KOD	d (mm)	SIKMA KAPASİTESİ (mm)	FİYAT USD
ER25.2	2	2-1,5	
ER25.3	3	3-2	
ER25.4	4	4-3	
ER25.5	5	5-4	
ER25.6	6	6-5	
ER25.7	7	7-6	
ER25.8	8	8-7	
ER25.9	9	9-8	
ER25.10	10	10-9	
ER25.11	11	11-10	
ER25.12	12	12-11	
ER25.13	13	13-12	
ER25.14	14	14-13	
ER25.15	15	15-14	
ER25.16	16	16-15	

KOD	d (mm)	SIKMA KAPASİTESİ (mm)	FİYAT USD
ER32.3	3	3-2	
ER32.4	4	4-3	
ER32.5	5	5-4	
ER32.6	6	6-5	
ER32.7	7	7-6	
ER32.8	8	8-7	
ER32.9	9	9-8	
ER32.10	10	10-9	
ER32.11	11	11-10	
ER32.12	12	12-11	
ER32.13	13	13-12	
ER32.14	14	14-13	
ER32.15	15	15-14	
ER32.16	16	16-15	
ER32.17	17	17-16	
ER32.18	18	18-17	
ER32.19	19	19-18	
ER32.20	20	20-19	

KOD	d (mm)	SIKMA KAPASİTESİ (mm)	FİYAT USD
ER40.3	3	3-2	
ER40.4	4	4-3	
ER40.5	5	5-4	
ER40.6	6	6-5	
ER40.7	7	7-6	
ER40.8	8	8-7	
ER40.9	9	9-8	
ER40.10	10	10-9	
ER40.11	11	11-10	
ER40.12	12	12-11	
ER40.13	13	13-12	
ER40.14	14	14-13	
ER40.15	15	15-14	
ER40.16	16	16-15	
ER40.17	17	17-16	
ER40.18	18	18-17	
ER40.19	19	19-18	
ER40.20	20	20-19	
ER40.21	21	21-20	
ER40.22	22	22-21	
ER40.23	23	23-22	
ER40.24	24	24-23	
ER40.25	25	25-24	
ER40.26	26	26-25	
ER40.27	27	27-26	
ER40.28	28	28-27	
ER40.29	29	29-28	
ER40.30	30	30-29	

FİYAT USD

ER25 PENS SETİ



SET İÇİNDE 12 ADET PENS VARDIR.

3-2	4-3	5-4	6-5	7-6	8-7
9-8	10-9	11-10	12-11	14-13	16-15

FİYAT USD

ER32 PENS SETİ



SET İÇİNDE 16 ADET PENS VARDIR.

3-2	4-3	5-4	6-5	7-6	8-7
9-8	10-9	11-10	12-11	13-12	14-13
15-14	16-15	18-17	20-19		

FİYAT USD

ER40 PENS SETİ



SET İÇİNDE 16 ADET PENS VARDIR.

4-3	5-4	6-5	7-6	8-7	9-8
10-9	12-11	14-13	16-15	18-17	20-19
22-21	24-23	25-24	26-25		

OTOMATİK KILAVUZ ÇEKME APARATI

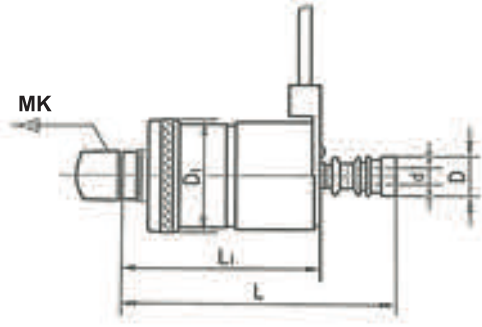

OTOMATİK KILAVUZ ÇEKME APARATININ MONTAJI

- 1- Kılavuz çekme aparatı mors konik kısmından matkap fener miline bağlanır.
- 2- Kılavuz, uygun pens kullanılarak kılavuz çekme aparatına monte edilir. Bu işlem sırasında kılavuzun kare kesitli kısmının mekanik kılavuz çekme aparatı üzerindeki yuvasına allen anahtar yardımıyla bağlanması gerekmektedir.
- 3- Dayama pimi matkap tezgahı çalıştığında sabit kalacak şekilde başka bir dayama pimine (matkap tezgahı gövdesindeki bir dayamaya, matkap tablasına bağlanan saplamaya vs.) dayanır.

OTOMATİK KILAVUZ ÇEKME APARATIYLA DIŞ ÇEKME

- 1- İş parçası matkap tablasına, kılavuz eksenine ve dış çekilecek delik eksenine çıkacak şekilde sabitlenir.
- 2- Matkap tezgahı dış çekme yönünde çalıştırılır.
- 3- Matkap talaş verme kolu, kılavuz dış çekilecek deliği ağızlayınca kadar aşağı doğru çevrilir.
- 4- Kılavuz istenilen boyda dış çekme işlemini tamamlayınca kadar, matkap talaş verme kolu aşağı doğru çevrilmeye devam edilir.
- 5- Kılavuz istenilen boyda dış çekme işlemini tamamlayınca, matkap talaş verme kolu yukarı doğru çevrilir. Bu işlem sırasında mekanik kılavuz çekme aparatının pens kısmı aparatın dışarı doğru çıkacaktır ve sadece pens kısmı dış çekme yönünün tersi yönde dönmeye başlayacaktır.
- 6- Kılavuz delikten kurtulunca, pens kısmı yaylı mekanizması sayesinde eski konumunu alacaktır ve tekrar dış çekme yönünde dönecektir.

KOD	ÖLÇÜ	d (mm)	D (mm)	D ₁ (mm)	L (mm)	L ₁ (mm)	MK	FİYAT USD
C006-207	M2-M7	2.5-6.5	23	55	135	95	MK2-MK3	
C006-512	M5-M12	3.5-10	28	75	164	114,5	MK3-MK4	
C006-820	M8-M20	6.3-14	38	90,5	205	135	MK3-MK4	

OTOMATİK KILAVUZ ÇEKME YEDEK PENSLER		FİYAT USD	
KOD	ÖLÇÜ		
C006-207P	M2-M7 İÇİN YEDEK PENS (2'Lİ SET)		
C006-512P	M5-M12 İÇİN YEDEK PENS (2'Lİ SET)		
C006-820P	M8-M20 İÇİN YEDEK PENS (2'Lİ SET)		

TERS KILAVUZ TAKIMLARI HSS



KOD	ADET	ÖLÇÜ	FİYAT USD
C345-5	5 PARÇA	M3-M6/M6-M8/M8-M11/ M11-14/M14-M18	
C345-6	6 PARÇA	M3-M6/M6-M8/M8-M11/M11-14/M14-M18/M18-24	
C345-8	8 PARÇA	M3-M6/M6-M8/M8-M11/M11-14/M14-M18/M18-24/M24-M30/M30-M40	

DÖKÜM KILAVUZ KOLU

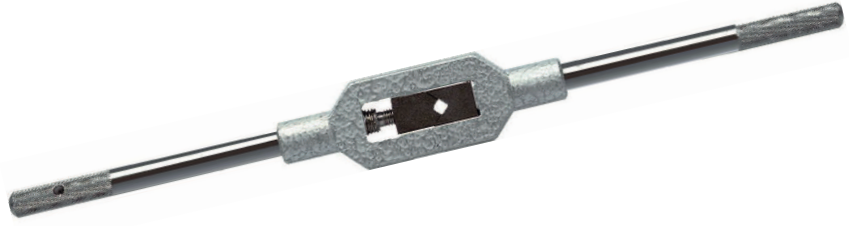
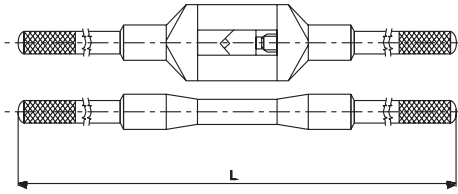

KOD	L (mm)	ÖLÇÜ (mm)	FİYAT USD
C350.00S	170	0 (M1 - M8)	
C350.15S	200	1-1/2 (M1 - M12)	
C350.20S	255	2 (M4 - M12)	
C350.30S	345	3 (M5 - M20)	
C350.40S	425	4 (M9 - M27)	
C350.50S	765	5 (M13 - M32)	
C350.60S	870	6 (M20 - M40)	
C350.70S	980	7 (M25 - M52)	

DÖKÜM PAFTA KOLU

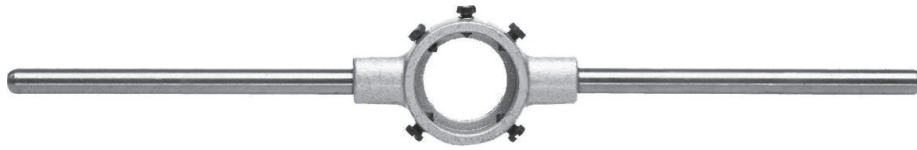
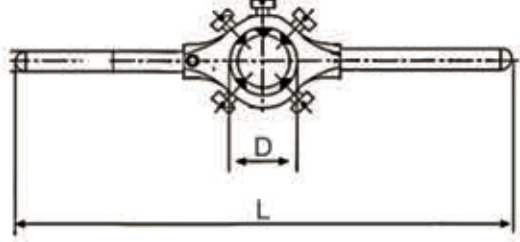

KOD	D (mm)	L (mm)	FİYAT USD
C351.16	16	140	
C351.20	20	175	
C351.25	25	210	
C351.30	30	255	
C351.38	38	300	
C351.45	45	450	
C351.55	55	490	
C351.65	65	550	
C351.75	75	550	
C351.90	90	800	
C351.105	105	900	

CIRCIRLI KILAVUZ KOLU



KOD	BOY (mm)	ÖLÇÜ (mm)	FİYAT USD
C341.10	85	1 (M3 - M8)	
C341.20	110	2 (M5 -M12)	
C341.100	250	10 (M3 - M8)	
C341.200	310	20 (M5 -M12)	

KIRIK KILAVUZ ÇIKARMA 9'LU SET

ÖZELLİKLER

- DELİK İÇİNDE KALAN KIRIK KILAVUZ PARÇALARINI KOLAYCA VE DELİĞE ZARAR VERMEDEN ÇIKARMAK İÇİN KULLANILIR.
- KULLANILMASI GEREKEN ÇIKARMA APARATI, KILAVUZ ÖLÇÜSÜNE GÖRE DEĞİŞMEKTEDİR.
- SET HALİNDE SATILIR.



KIRIK KILAVUZ ÇIKARMA 9'LU SET				C346-09
BOYUT	KILAVUZ ÖLÇÜSÜ		AĞIZ SAYISI	FİYAT USD
2#	M5	M8-M10	3	
3#	M6	1/4"	3	
4#	M8	5/16"	3	
5#	M10	3/8"	3	
6#	M12	1/2"	4	
7#	M14	9/16"	4	
8#	M16	5/8"	4	
9#	M18-M20	3/4"	4	
10#	M22	7/8"	4	

METAL DAİRE TESTERELER

DIN 1837A HSS

HSS

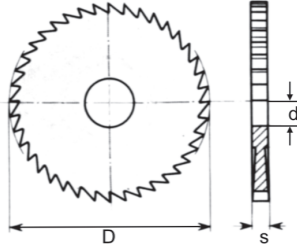
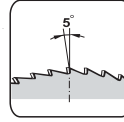
DIN
1837A

DxS (mm)	d (mm)	Z Diş Sayısı	C700 FİYAT USD
25X0,4	8	48	
25X0,6	8	48	
25X1,0	8	48	
25X1,2	8	48	
25X1,5	8	48	
25X1,6	8	48	
25X2,0	8	48	
32X1,0	8	48	
32X1,2	8	48	
32X1,5	8	48	
32X1,6	8	48	
32X2,0	8	48	
32X4,0	8	32	
32X3,0	8	32	
32X5,0	8	32	
40X0,2	10	128/160	
40X0,25	10	100/160	
40X0,3	10	100/160	
40X0,4	10	128/160	
40X0,5	10	80	
40X0,6	10	80	
40X0,7	10	80	
40X0,8	10	80	
40X0,9	10	80	
40X1,0	10	64	
40X1,2	10	64	
40X1,5	10	64	
40X1,6	10	64	
40X2,0	10	48	
40X2,5	10	48	
40X3,0	10	48	
50X0,2	13	128/200	
50X0,25	13	128/200	
50X0,3	10/13	128/160/200	
50X0,4	13	100/200	
50X0,5	13	100/200	
50X0,6	13	100	
50X0,7	13	100	

DxS (mm)	d (mm)	Z Diş Sayısı	C700 FİYAT USD
50X0,8	13	80	
50X0,9	13	80	
50X1,0	13	80	
50X1,2	13	80	
50X1,5	13	64	
50X1,6	13	64	
50X2,0	13	64	
50X2,5	13	64	
50X3,0	13	48	
50X4,0	13	48	
50X5,0	13	48	
63X0,2	10/13/16	128/200	
63X0,25	13/16	150/200	
63X0,3	10/13/16	128/200	
63X0,4	10/13/16	128/200	
63X0,5	13/16	128/200	
63X0,6	16	100	
63X0,7	16	100	
63X0,8	16	100	
63X0,9	16	100	
63X1,0	16	100	
63X1,2	16	100	
63X1,5	16	80	
63X1,6	16	80	
63X2,0	16	80	
63X2,5	16	64	
63X3,0	16	64	
63X3,5	16	64	
63X4,0	16	64	
63X5,0	16	48	
63X6,0	16	48	
80X0,3	22	160	
80X0,4	22	160	
80X0,5	22	128	
80X0,6	22	128	
80X0,7	22	128	
80X0,8	22	128	
80X0,9	22	128	



METAL DAİRE TESTERELER

DIN 1837A HSS

HSS

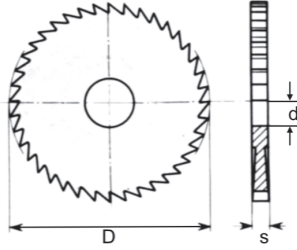
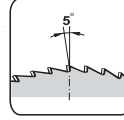
DIN
1837A

DxS (mm)	d (mm)	Z Diş Sayısı	C700 FİYAT USD
80X1,0	22	100	
80X1,2	22	100	
80X1,4	22	100	
80X1,5	22	100	
80X1,6	22	100	
80X2,0	22	80	
80X2,5	22	80	
80X3,0	22	80	
80X3,5	22	80	
80X4,0	22	64	
80x5,0	22	64	
80x6,0	22	64	
100X0,5	22	160	
100X0,6	22	160	
100X0,7	22	160	
100X0,8	22	128	
100X0,9	22	128	
100X1,0	22	128	
100X1,2	22	128	
100X1,5	22	128	
100X1,6	22	100	
100X2,0	22	100	
100X2,5	22	100	
100X3,0	22	80	
100X3,5	22	80	
100X4,0	22	80	
100X5,0	22	80	
100X6,0	22	64	
125X0,6	22/27	160	
125X0,8	22/27	160	
125X1,0	22/27	160	
125X1,2	22/27	128	
125X1,5	22/27	128	
125X1,6	22/27	128	
125X2,0	22/27	64/128	
125X2,5	22/27	64/100	
125X3,0	22/27	100	
125X3,5	22/27	100	

DxS (mm)	d (mm)	Z Diş Sayısı	C700 FİYAT USD
125X4,0	22/27	100	
125X5,0	22/27	80	
125X6,0	22/27	80	
160X1,0	32	160	
160X1,2	32	80/100/160	
160X1,4	32	80	
160X1,6	32	80/100/160	
160X2,0	32	128	
160X2,5	32	128	
160X3,0	32	128	
160X3,5	32	64/128	
160X4,0	32	64/100	
160X5,0	32	100	
160X6,0	32	100	
200X1,0	32	100/200	
200X1,2	32	100/200	
200X1,5	32	160/200	
200X1,6	32	100/160/200	
200X2,0	32	80/160	
200X2,5	32	160	
200X3,0	32	128	
200X3,5	32	128	
200X4,0	32	128	
200X4,5	32	128	
200X5,0	32	128	
200X6,0	32	100	
250X2,0	32	200	
250X2,5	32	160/200	
250X3,0	32	160/200	
250X4,0	32	160	
250X5,0	32	160	
275X2,5	32	220	
275X3,0	32	160	
275X4,0	32	160	
275X5,0	32	160	
300X3,0	32	160	
300X4,0	32	160	
300X5,0	32	160	

KARBÜR DAİRE TESTERELER

DIN 1837A

VHM

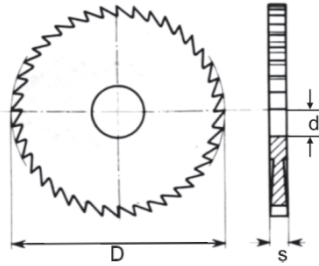
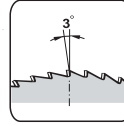
DIN
1837A

DxS (mm)	d (mm)	Z Diş Sayısı	C702
			FİYAT USD
30x0,5	10	80	
30x0,6	10	80	
30x0,7	10	80	
30x0,8	10	80	
30x0,9	10	80	
30x1,0	10	64	
30x1,2	10	64	
30x1,5	10	64	
30x1,6	10	64	
30x2,0	10	48	
30x2,5	10	48	
30x3,0	10	48	
40x0,2	10	128	
40x0,3	10	100	
40x0,4	10	100	
40x0,5	10	80	
40x0,6	10	80	
40x0,7	10	80	
40x0,8	10	80	
40x1,0	10	64	
40x1,2	10	64	
40x1,5	10	64	
40x1,6	10	64	
40x2,0	10	48	
40x2,5	10	48	

DxS (mm)	d (mm)	Z Diş Sayısı	C702
			FİYAT USD
40x3,0	10	48	
50x1,0	13	80	
50x1,5	13	64	
50x2,0	13	64	
50x2,5	13	64	
50x3,0	13	48	
63x1,0	16	100	
63x1,5	16	80	
63x2,0	16	64	
63x2,5	16	64	
63x3,0	16	64	
63x3,5	16	64	
80x1,0	22	100	
80x1,5	22	100	
80x2,0	22	80	
80x2,5	22	80	
80x3,0	22	80	
80x3,5	22	80	
100x1,0	22	128	
100x1,5	22	128	
100x2,0	22	100	
100x2,5	22	100	
100x3,0	22	80	
100x3,5	22	80	

KARE KESİTLİ TORNA KALEMİ

DIN4964/B

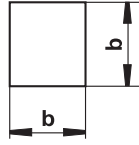
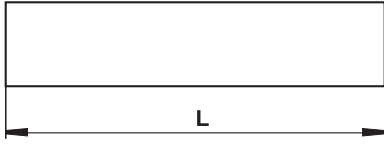

b (mm)	b (mm)	L (mm)	C4964B
			HSS
			FİYAT USD
4	4	100	
5	5	100	
5	5	125	
6	6	160	
6	6	200	
8	8	160	
8	8	200	
10	10	160	
10	10	200	
12	12	160	
12	12	200	
14	14	160	
14	14	200	
16	16	160	
16	16	200	
18	18	200	
20	20	200	
25	25	200	

DİKDÖRTGEN KESİTLİ LAMA KALEMİ

DIN4964/D

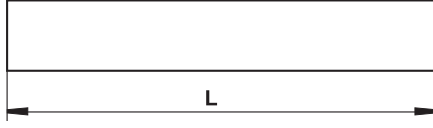

b (mm)	h (mm)	L (mm)	C4964D
			HSS
			FİYAT USD
3	12	200	
3	20	200	
4	8	160	
4	10	160	
4	12	160	
4	12	200	
4	14	160	
4	16	200	
4	18	200	
4	20	200	
5	8	200	
5	10	200	
5	12	200	
5	16	200	
5	18	200	
5	20	200	
5	25	200	
6	10	200	
6	12	200	
6	16	200	
6	20	200	

b (mm)	h (mm)	L (mm)	C4964D
			HSS
			FİYAT USD
6	25	200	
6	32	200	
8	12	200	
8	14	200	
8	16	200	
8	20	200	
8	25	200	
8	40	200	
10	14	200	
10	16	200	
10	20	200	
10	25	200	
10	30	200	
10	32	200	
10	40	200	
10	50	200	
12	14	200	
12	16	200	
12	20	200	
12	25	200	

TRAPEZ KESİTLİ KESME KALEMİ

DIN 4964/E

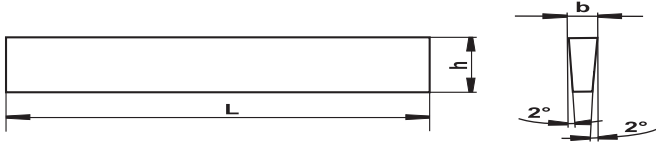

b (mm)	h (mm)	L (mm)	C4964E
			HSS
			FİYAT USD
2,5	10 (3/8")	160	
3	12 (1/2")	160	
3	16 (5/8")	160	
3	20 (3/4")	160	
4	16 (5/8")	160	

b (mm)	h (mm)	L (mm)	C4964E
			HSS
			FİYAT USD
4	20 (3/4")	160	
5	20 (3/4")	160	
5	22 (7/8")	160	
6	25 (1")	160	

YUVARLAK KESİTLİ PANTOGRAF KALEMİ

DIN 4964/A

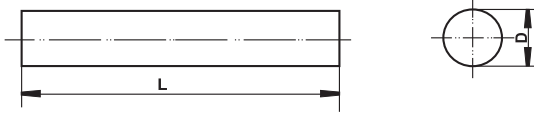

D (mm)	L (mm)	C4964A
		HSS
		FİYAT USD
3	100	
4	100	
5	100	
6	100	
8	160	
10	200	

D (mm)	L (mm)	C4964A
		HSS
		FİYAT USD
12	200	
14	200	
16	200	
18	200	
20	200	

SERT METAL (KARBÜR) K10 TORNA KALEMİ

b (mm)	b (mm)	L (mm)	C264
			FİYAT USD
4	4	100	
5	5	100	
6	6	100	
8	8	100	
10	10	100	
12	12	100	
14	14	100	

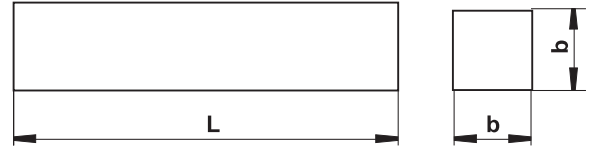

SERT METAL (KARBÜR) K10 PANTOGRAF KALEMİ

D (mm)	L (mm)	C265
		FİYAT USD
3	100	
4	100	
5	100	
6	100	
8	100	
10	100	
12	100	



**KIRMA
APARATI**



**TAKMA
APARATI**



**HELICOIL
YAYLAR**



**HELICOIL
KILAVUZU
DÜZ**



**HELICOIL
KILAVUZU
HELİS**



ÖLÇÜ	DİŞ HATVESİ	HELICOIL YAY			DÜZ KILAVUZ	HELİS KILAVUZ	TAKMA APARATI	KIRMA APARATI	MATKAP ÇAPLARI
		1D	1.5D	2D					
		FİYAT USD	FİYAT USD	FİYAT USD					
M2	0,40								2,1
M2,5	0,45								2,6
M3	0,50								3,2
M4	0,70								4,2
M5	0,80								5,2
M6	1,00								6,3
M7	1,00								7,3
M8	1,00								8,3
M8	1,25								8,3
M9	1,25								9,3
M10	1,00								10,3
M10	1,25								10,3
M10	1,50								10,4
M11	1,50								11,4
M12	1,00								12,3
M12	1,25								12,3
M12	1,50								12,4
M12	1,75								12,4
M14	1,00								14,3
M14	1,25								14,4
M14	1,50								14,4
M14	2,00								14,5
M16	1,00								16,4
M16	1,50								16,4

KIRMA
APARATITAKMA
APARATIHELICOIL
YAYLARHELICOIL
KILAVUZU
DÜZHELICOIL
KILAVUZU
HELİS

ÖLÇÜ	DİŞ HATVESİ	HELICOIL YAY			DÜZ KILAVUZ	HELİS KILAVUZ	TAKMA APARATI	KIRMA APARATI	MATKAP ÇAPLARI
		1D	1.5D	2D					
		FİYAT USD	FİYAT USD	FİYAT USD					
M16	2,00								16,5
M18	1,00								18,5
M18	1,50								18,5
M18	2,00								18,5
M18	2,50								18,6
M20	1,00								20,5
M20	1,50								20,5
M20	2,00								20,5
M20	2,50								20,6
M22	1,50								22,5
M22	2,50								22,6
M24	1,50								24,5
M24	3,00								24,75
M26	1,50								26,5
M26	3,00								26,75
M27	1,50								27,5
M27	3,00								27,75
M28	1,50								28,5
M28	3,00								28,75
M30	1,50								30,5
M30	3,50								31
M33	3,50								34
M36	4,00								37

UNF DİŞ HELICOIL YAY VE KILAVUZU

HELICOIL
YAYLARHELICOIL
KILAVUZU
DÜZHELICOIL
KILAVUZU
HELİS

ÖLÇÜ	DİŞ HATVESİ	UNF 1.5D	UNF 2D	UNF DÜZ KILAVUZ	UNF HELİS KILAVUZ	MATKAP ÇAPLARI
		FİYAT USD	FİYAT USD	FİYAT USD	FİYAT USD	
UNF 1/4"	28					6,7
UNF 5/16"	24					8,3
UNF 3/8"	24					9,8
UNF 7/16"	20					11,5
UNF 1/2"	20					13
UNF 9/16"	18					14,8
UNF 5/8"	18					16,25
UNF 3/4"	16					19,5
UNF 7/8"	14					22,75
UNF 1"	12					26

UNC DİŞ HELICOIL YAY VE KILAVUZU

HELICOIL
YAYLARHELICOIL
KILAVUZU
DÜZHELICOIL
KILAVUZU
HELİS

ÖLÇÜ	DİŞ HATVESİ	UNC 1.5D	UNC 2D	UNC DÜZ KILAVUZ	UNC HELİS KILAVUZ	MATKAP ÇAPLARI
		FİYAT USD	FİYAT USD	FİYAT USD	FİYAT USD	
UNC 1/4"	20					6,7
UNC 5/16"	18					8,3
UNC 3/8"	16					9,9
UNC 7/16"	14					11,6
UNC 1/2"	13					13
UNC 9/16"	12					14,8
UNC 5/8"	11					16,5
UNC 3/4"	10					19,75
UNC 7/8"	9					23
UNC 1"	8					26,25

WHITWORTH DİŞ HELICOIL YAY VE KILAVUZU

HELICOIL
YAYLARHELICOIL
KILAVUZU
DÜZHELICOIL
KILAVUZU
HELİS

ÖLÇÜ	DİŞ HATVESİ	W 1.5D	W 2D	W DÜZ KILAVUZ	W HELİS KILAVUZ	MATKAP ÇAPLARI
		FİYAT USD	FİYAT USD	FİYAT USD	FİYAT USD	
W 1/8"	40					3,4
W 3/16"	24					5,1
W 1/4"	20					6,7
W 5/16"	18					8,3
W 3/8"	16					9,9
W 7/16"	14					11,5
W 1/2"	12					13
W 9/16"	12					14,8
W 5/8"	11					16,7
W 3/4"	10					20
W 7/8"	9					23
W 1"	8					26,5

GAZ DİŞ HELICOIL YAY VE KILAVUZU

HELICOIL
YAYLARHELICOIL
KILAVUZU
DÜZHELICOIL
KILAVUZU
HELİS

ÖLÇÜ	DİŞ HATVESİ	G 1D	G 1.5D	G 2D	G DÜZ KILAVUZ	G HELİS KILAVUZ	MATKAP ÇAPLARI
		FİYAT USD	FİYAT USD	FİYAT USD	FİYAT USD	FİYAT USD	
G 1/8"	28						10
G 1/4"	19						13,6
G 3/8"	19						17,1
G 1/2"	14						21,5
G 5/8"	14						23,4
G 3/4"	14						27
G 7/8"	14						30,6
G 1"	11						33,7

DİŞ TAMİR TAKIMLARI

	KOD	ÖLÇÜ	YAY ADETİ	FİYAT USD
	CH.TT.M03	M3x0,5	20	
	CH.TT.M035	M3,5x0,35	20	
	CH.TT.M04	M4x0,7	20	
	CH.TT.M05	M5x0,8	20	
	CH.TT.M06	M6x1	20	
	CH.TT.M08	M8x1,25	20	
	CH.TT.M10	M10x1,5	20	
	CH.TT.M12	M12x1,75	10	
	CH.TT.M12125	M12x1,25	10	
	CH.TT.M14*	M14x2	10	
	CH.TT.M16*	M16x2	10	
	CH.TT.M18*	M18x2,5	5	
	CH.TT.M20*	M20x2,5	5	
ÜRÜN TANIMI	ÜRÜN KULLANIM ALANLARI			
Arızalı dişlerin tamirinin en etkili yöntemidir. Hasar görmüş veya aşınmış diş, hızlı ve kalıcı biçimde orjinal ölçüsüne getirilmesini sağlar. Metrik/inç değişimini sağlar. Paslanmaya ve aşınmaya dayanıklı malzemesi ile uzun kullanım ömrü sağlar.	Hemen hemen her türlü tapa yuvası ve vida deliğinde kullanılabilirdiği için otomotiv, uçak sanayi başta olmak üzere sağlamlık, kullanım ömrü ve yüksek operasyon hızı ile bütün sanayi kollarında kullanılabilir.			

* SET İÇİNDE MATKAP YOKTUR

DİŞ TAMİR TAKIMLARI (HELICOIL SET)

	KOD	ÖLÇÜ	FİYAT USD
	CH.TT.M5-M12 SET	M5-M6-M8-M10-M12	
ÜRÜN TANIMI	ÜRÜN KULLANIM ALANLARI		
Arızalı dişlerin tamirinin en etkili yöntemidir. Hasar görmüş veya aşınmış diş, hızlı ve kalıcı biçimde orjinal ölçüsüne getirilmesini sağlar. Metrik/inç değişimini sağlar. Paslanmaya ve aşınmaya dayanıklı malzemesi ile uzun kullanım ömrü sağlar.	Hemen hemen her türlü tapa yuvası ve vida deliğinde kullanılabilirdiği için otomotiv, uçak sanayi başta olmak üzere sağlamlık, kullanım ömrü ve yüksek operasyon hızı ile bütün sanayi kollarında kullanılabilir.		

HELICOIL YAY SÖKME APARATI

	KOD	ÖLÇÜ	FİYAT USD
	CH.YS-M3-10	M3-M10	
	CH.YS-M11-24	M11-M24	
ÜRÜN KULLANIM ALANLARI			
Hatalı takılmış yada önceden takılan deforme olmuş yayların çıkarılmasında kullanılır.			

METRİK NORMAL DİŞ VİDA MASTARI

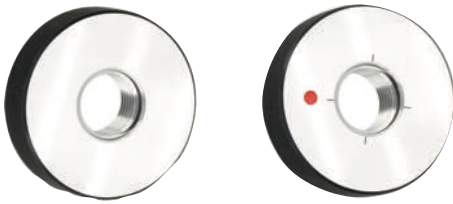
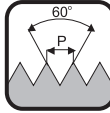

2 PARÇALI SET OLARAK TEMİN EDİLİR

ÖLÇÜ	DİŞ HATVESİ	ERKEK VİDA MASTARI (6H)	DİŞİ VİDA MASTARI (6g)
		C998	C997
		FİYAT USD	FİYAT USD
M2	0,4		
M2,5	0,45		
M3	0,5		
M3,5	0,6		
M4	0,7		
M5	0,8		
M6	1		
M7	1		
M8	1,25		
M9	1,25		
M10	1,5		
M12	1,75		
M14	2		
M16	2		
M18	2,5		
M20	2,5		
M22	2,5		
M24	3		
M26	3		
M27	3		
M30	3,5		
M33	3,5		
M36	4		
M39	4		
M42	4,5		
M45	4,5		
M48	5		
M52	5		
M56	5,5		
M60	5,5		

METRİK İNCE DİŞ VİDA MASTARI

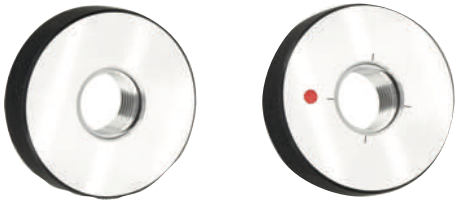
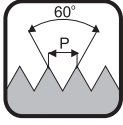

2 PARÇALI SET OLARAK TEMİN EDİLİR

ÖLÇÜ	DİŞ HATVESİ	ERKEK VİDA MASTARI (6H)	DİŞİ VİDA MASTARI (6g)
		C998	C997
		FİYAT USD	FİYAT USD
M4	0,5		
M5	0,5		
M6	0,75		
M8	1		
M8	0,75		
M9	1		
M10	1,25		
M10	1		
M10	0,75		
M12	1,5		
M12	1,25		
M12	1		
M14	1,5		
M14	1,25		
M14	1		
M16	1,5		
M16	1		
M18	2		
M18	1,5		
M18	1		
M20	2		
M20	1,5		
M20	1		
M22	2		
M22	1,5		
M22	1		
M24	2		
M24	1,5		
M24	1		
M25	2		
M25	1,5		
M25	1		
M26	2		
M26	1,5		
M26	1		
M27	2		
M27	1,5		



METRİK İNCE DİŞ VİDA MASTARI

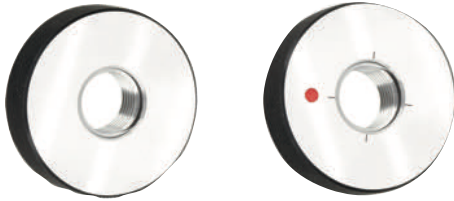
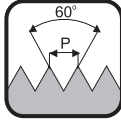

2 PARÇALI SET OLARAK TEMİN EDİLİR

ÖLÇÜ	DİŞ HATVESİ	ERKEK VİDA MASTARI (6H)	DİŞİ VİDA MASTARI (6g)
		C998	C997
		FİYAT USD	FİYAT USD
M28	2		
M28	1,5		
M28	1		
M30	2		
M30	1,5		
M32	2		
M32	1,5		
M33	2		
M33	1,5		
M34	2		
M34	1,5		
M35	1,5		
M36	3		
M36	2		
M36	1,5		
M38	1,5		
M39	3		
M39	2		
M39	1,5		
M40	3		
M40	2		
M40	1,5		
M40	1		
M42	3		
M42	2		
M42	1,5		
M45	3		
M45	2		
M45	1,5		
M48	3		
M48	2		
M48	1,5		
M50	3		
M50	2		
M50	1,5		
M52	3		
M52	2		
M52	1,5		

GAZ DİŞ VİDA MASTARI

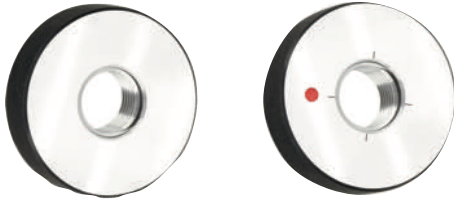
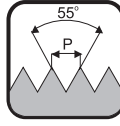

2 PARÇALI SET OLARAK TEMİN EDİLİR

ÖLÇÜ	DİŞ HATVESİ	ERKEK VİDA MASTARI (2B)	DİŞİ VİDA MASTARI (2A)
		C998	C997
		FİYAT USD	FİYAT USD
G1/8	28		
G1/4	19		
G3/8	19		
G1/2	14		
G5/8	14		
G3/4	14		
G7/8	14		
G1	11		
G1 1/4	11		
G1 1/2	11		
G2	11		
G2 1/2	11		
G3	11		

NPT DİŞ VİDA MASTARI

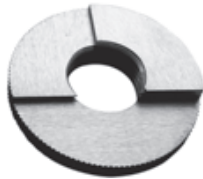
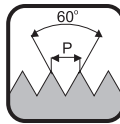

TEK PARÇA OLARAK TEMİN EDİLİR

ÖLÇÜ	DİŞ HATVESİ	ERKEK VİDA MASTARI (2B)	DİŞİ VİDA MASTARI (2A)
		C998	C997
		FİYAT USD	FİYAT USD
NPT1/16	27		
NPT1/8	27		
NPT1/4	18		
NPT3/8	18		
NPT1/2	14		
NPT3/4	14		
NPT1	11,5		
NPT1 1/4	11,5		
NPT1 1/2	11,5		
NPT2	11,5		

UNF DİŞ VİDA MASTARI

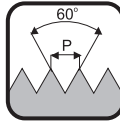

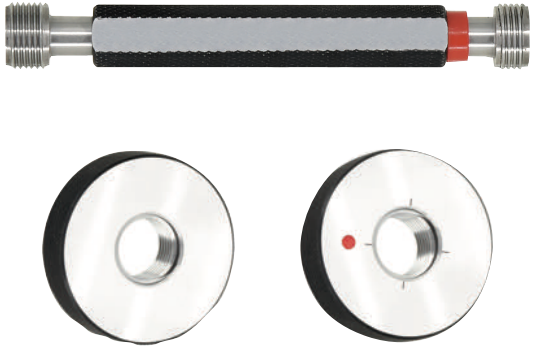
 <p>2 PARÇALI SET OLARAK TEMİN EDİLİR</p>	ÖLÇÜ	DİŞ HATVESİ	ERKEK VİDA MASTARI (2B)	DİŞİ VİDA MASTARI (2A)
			C998	C997
			FİYAT USD	FİYAT USD
UNF1/4	28			
UNF5/16	24			
UNF3/8	24			
UNF7/16	20			
UNF1/2	20			
UNF9/16	18			
UNF5/8	18			
UNF3/4	16			
UNF7/8	14			
UNF1	12			
UNF1	14			
UNF11/16	16			
UNF13/16	16			
UNF1 5/8	12			
UNF1 7/8	12			
UNF2	12			

UNC DİŞ VİDA MASTARI

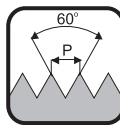

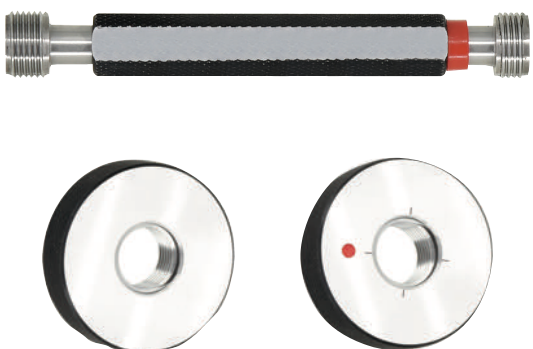
 <p>2 PARÇALI SET OLARAK TEMİN EDİLİR</p>	ÖLÇÜ	DİŞ HATVESİ	ERKEK VİDA MASTARI (2B)	DİŞİ VİDA MASTARI (2A)
			C998	C997
			FİYAT USD	FİYAT USD
UNC1/4	20			
UNC5/16	18			
UNC3/8	16			
UNC7/16	14			
UNC1/2	13			
UNC9/16	12			
UNC5/8	11			
UNC3/4	10			
UNC7/8	9			
UNC1	8			

DELİK BÜYÜTME SETİ

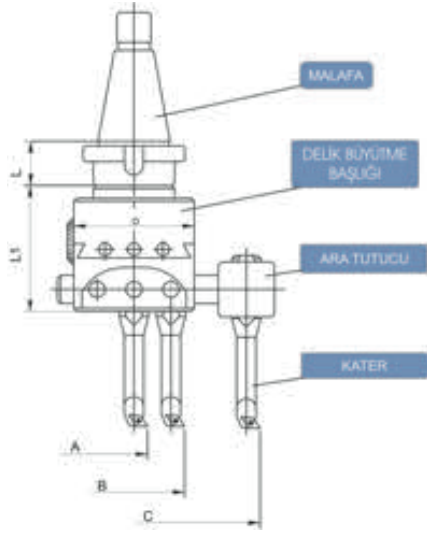

MALAFA	DELİK BÜYÜTME	D (mm)	L (mm)	L1 (mm)	KULLANILAN KATERİN ARKA ÇAPLARI mm	İŞLEME KAPASİTELERİ						AÇILMA (mm)	C740 FİYAT USD
						A (mm)		B (mm)		C (mm)			
						Min.	Max.	Min.	Max.	Min.	Max.		
IS030	F1 - 12	50	29	62	10-12	13,6	45	45	77	94	177	16	
					12-12	17	49	48	80	97	180		
IS040	F1 - 12	50	31	62	10-12	13,6	45	45	77	94	177	16	
					12-12	17	49	48	80	97	180		
IS050	F1 - 12	50	34,5	62	10-12	13,6	45	45	77	94	177	16	
					12-12	17	49	48	80	97	180		
BT30	F1 - 12	50	46	62	10-12	13,6	45	45	77	94	177	16	
					12-12	17	49	48	80	97	180		
BT40	F1 - 12	50	46	62	10-12	13,6	45	45	77	94	177	16	
					12-12	17	49	48	80	97	180		
BT50	F1 - 12	50	46	62	10-12	13,6	45	45	77	94	177	16	
					12-12	17	49	48	80	97	180		
MK3	F1 - 12	50	42,5	62	10-12	13,6	45	45	77	94	177	16	
					12-12	17	49	48	80	97	180		
MK4	F1 - 12	50	49	62	10-12	13,6	45	45	77	94	177	16	
					12-12	17	49	48	80	97	180		
MK4KM	F1 - 12	50	49	62	10-12	13,6	45	45	77	94	177	16	
					12-12	17	49	48	80	97	180		
IS030	F1 - 18	75	29	80	10-18	13,6	63	61	111	125	225	25	
					12-18	17	67	64	114	127	228		
					16-18	21	71	68	118	131	232		
IS040	F1 - 18	75	31	80	10-18	13,6	63	61	111	125	225	25	
					12-18	17	67	64	114	127	228		
					16-18	21	71	68	118	131	232		
IS050	F1 - 18	75	34,5	80	10-18	13,6	63	61	111	125	225	25	
					12-18	17	67	64	114	127	228		
					16-18	21	71	68	118	131	232		
BT30	F1 - 18	75	46	80	10-18	13,6	63	61	111	125	225	25	
					12-18	17	67	64	114	127	228		
					16-18	21	71	68	118	131	232		
BT40	F1 - 18	75	46	80	10-18	13,6	63	61	111	125	225	25	
					12-18	17	67	64	114	127	228		
					16-18	21	71	68	118	131	232		
BT50	F1 - 18	75	46	80	10-18	13,6	63	61	111	125	225	25	
					12-18	17	67	64	114	127	228		
					16-18	21	71	68	118	131	232		
MK3	F1 - 18	75	42,5	80	10-18	13,6	63	61	111	125	225	25	
					12-18	17	67	64	114	127	228		
					16-18	21	71	68	118	131	232		
MK4	F1 - 18	75	49	80	10-18	13,6	63	61	111	125	225	25	
					12-18	17	67	64	114	127	228		
					16-18	21	71	68	118	131	232		
MK4KM	F1 - 18	75	49	80	10-18	13,6	63	61	111	125	225	25	
					12-18	17	67	64	114	127	228		
					16-18	21	71	68	118	131	232		

DELİK BÜYÜTME SETİ

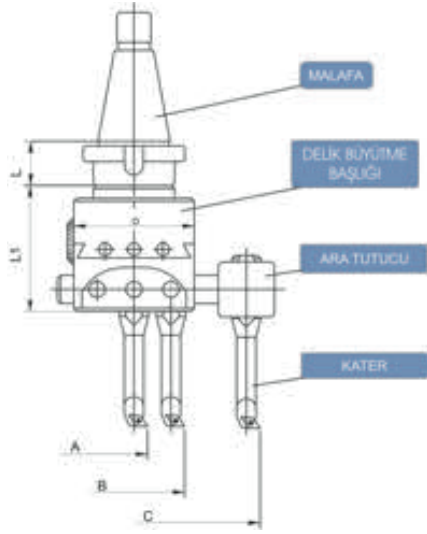

MALAFA	DELİK BÜYÜTME	D (mm)	L (mm)	L1 (mm)	KULLANILAN KATERİN ARKA ÇAPLARI mm	İŞLEME KAPASİTELERİ						AÇILMA (mm)	C740 FİYAT USD
						A (mm)		B (mm)		C (mm)			
						Min.	Max.	Min.	Max.	Min.	Max.		
MK5	F1 - 18	75	55,5	80	10-18	13,6	63	61	111	125	225	25	
					12-18	17	67	64	114	127	228		
					16-18	21	71	68	118	131	232		
MK5KM	F1 - 18	75	55,5	80	10-18	13,6	63	61	111	125	225	25	
					12-18	17	67	64	114	127	228		
					16-18	21	71	68	118	131	232		
ISO30	F1 - 25	100	29	80	16-25	21	103	84	166	166	300	41	
					20-25	25	107	88	170	170	303		
					25-25	32	114	95	177	177	310		
ISO40	F1 - 25	100	31	80	16-25	21	103	84	166	166	300	41	
					20-25	25	107	88	170	170	303		
					25-25	32	114	95	177	177	310		
ISO50	F1 - 25	100	34,5	80	16-25	21	103	84	166	166	300	41	
					20-25	25	107	88	170	170	303		
					25-25	32	114	95	177	177	310		
BT30	F1 - 25	100	46	80	16-25	21	103	84	166	166	300	41	
					20-25	25	107	88	170	170	303		
					25-25	32	114	95	177	177	310		
BT40	F1 - 25	100	46	80	16-25	21	103	84	166	166	300	41	
					20-25	25	107	88	170	170	303		
					25-25	32	114	95	177	177	310		
BT50	F1 - 25	100	46	80	16-25	21	103	84	166	166	300	41	
					20-25	25	107	88	170	170	303		
					25-25	32	114	95	177	177	310		
MK3	F1 - 25	100	42,5	80	16-25	21	103	84	166	166	300	41	
					20-25	25	107	88	170	170	303		
					25-25	32	114	95	177	177	310		
MK4	F1 - 25	100	49	80	16-25	21	103	84	166	166	300	41	
					20-25	25	107	88	170	170	303		
					25-25	32	114	95	177	177	310		
MK4KM	F1 - 25	100	49	80	16-25	21	103	84	166	166	300	41	
					20-25	25	107	88	170	170	303		
					25-25	32	114	95	177	177	310		
MK5	F1 - 25	100	55,5	80	16-25	21	103	84	166	166	300	41	
					20-25	25	107	88	170	170	303		
					25-25	32	114	95	177	177	310		
MK5KM	F1 - 25	100	55,5	80	16-25	21	103	84	166	166	300	41	
					20-25	25	107	88	170	170	303		
					25-25	32	114	95	177	177	310		

DELİK BÜYÜTME BAŞLIĞI

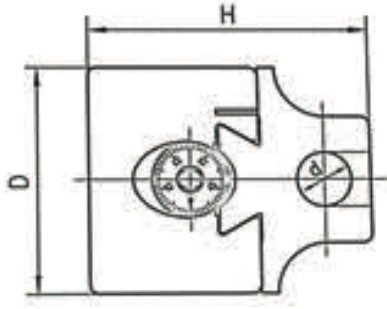

ÖLÇÜ	D (mm)	H (mm)	MAX. AÇILMA (mm)	d (mm)	MİN.ÖLÇEK		C741
							FİYAT USD
1-12	50	62	16	12	0,01 mm	10-125	
1-18	75	80	25	18	0,01 mm	12-225	
1-25	100	94	41	25	0,01 mm	15-320	

DELİK BÜYÜTME BARA TAKIMI

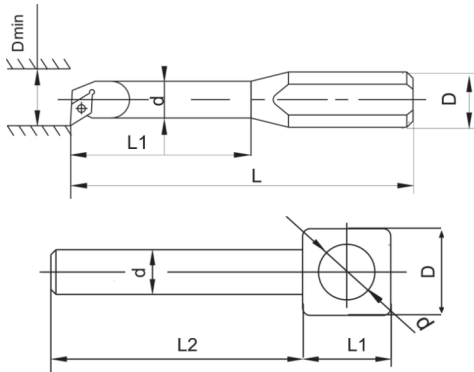

ÖLÇÜ	KATER TUTUCU	d (mm)	D (mm)	L1 (mm)	L (mm)	D min.	KESİCİ UÇ	C742
								FİYAT USD
F1-12	10-12 KATER	10	12	50	95	13,6	DCMT 0702...	
	12-12 KATER	12	12	-	110	17	DCMT 0702...	
	12 ARA TUTUCU	12	30	30	75	-	-	
F1-18	10-18 KATER	10	18	50	95	13,6	DCMT 0702...	
	12-18 KATER	12	18	-	110	17	DCMT 0702...	
	16-18 KATER	16	18	30	75	-	DCMT 11T3...	
	18 ARA TUTUCU	18	35	35	100	-	-	
F1-25	16-25 KATER	16	25	93	144	21	DCMT 11T3...	
	20-25 KATER	20	25	93	144	25	DCMT 11T3...	
	25-25 KATER	25	25	-	144	32	DCMT 11T3...	
	25 ARA TUTUCU	25	40	45	125	-	-	

DELİK BÜYÜTME MALAFASI

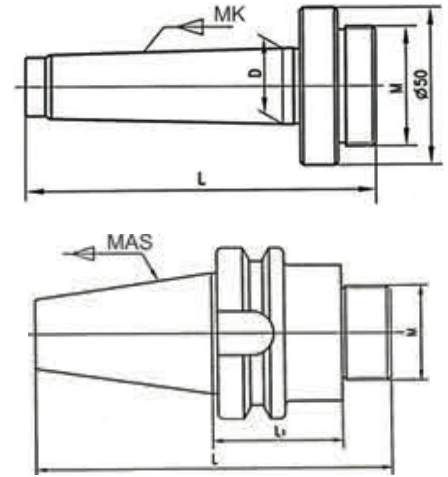
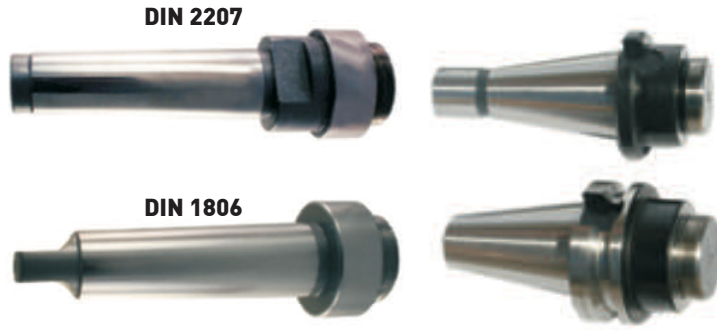

MALAFA	L (mm)	L ₁ (mm)	D (mm)	M	C741
					FİYAT USD
ISO 30	102	29	-	7/8"-20	
ISO 40	135	31	-		
ISO 50	168	34,5	-		
BT 30	98	41	-		
BT 40	122,4	46	-		
BT 50	175	74	-		
SK 40	122,4	46	-		
SK 50	175	74	-		
MK 3	128	-	23,825		
MK 4	154	-	31,267		
MK 4 KM	154	-	31,267		
MK 5	186	-	44,399		
MK 5 KM	186	-	44,399		
MK 6 KM	248	-	63,648		

MANYETİK V-YATAK TEK ÖLÇÜM İÇİN

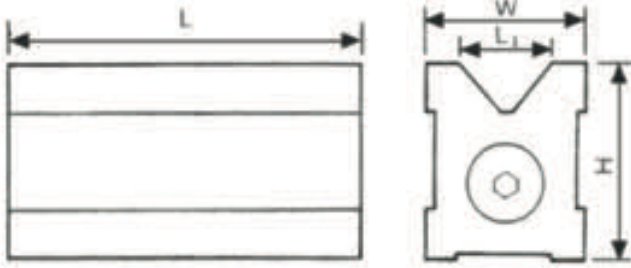

KOD	H (mm)	W (mm)	L (mm)	L1 (mm)	ÇEKME KUVVETİ (Kg)	AĞIRLIK (Kg)	FİYAT USD
C901-0090	72	65	70	45	90	1,5	
C901-0145	95	70	100	50	145	3,5	

MANYETİK V-YATAK ÇİFT ÖLÇÜM İÇİN (2 ADET)

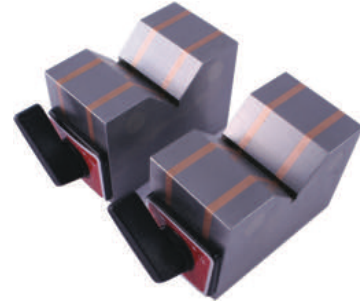
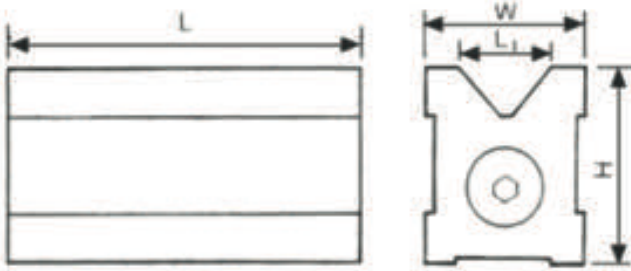

KOD	H (mm)	W (mm)	L (mm)	L1 (mm)	AĞIRLIK (Kg)	FİYAT USD
C899-50	50	40	70	30	1x2	
C899-80	80	50	100	60	3x2	

PARALEL V-YATAK İŞLEME İÇİN (2 ADET)



KOD	GENİŞLİK (mm)	YÜKSEKLİK (mm)	UZUNLUK (mm)	AĞIRLIK (Kg)	FİYAT USD
C902-44	44	41	35	1,2	
C902-70	70	44	41	1,9	

AYARLANABİLİR V YATAK

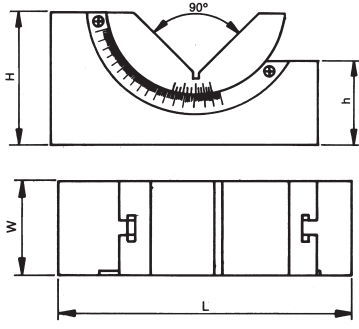

KOD	H (mm)	W (mm)	L (mm)	h (mm)	AĞIRLIK (Kg)	FİYAT USD
C005-30	48	30	102	28	0,9	

GÖNYE PLEYTİ

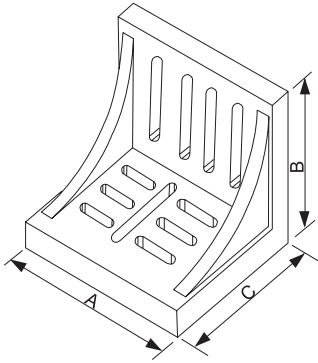

KOD	A (mm)	B (mm)	C (mm)	AĞIRLIK (Kg)	FİYAT USD
C012-250	250	200	150	10	
C012-300	300	230	200	13	

MANYETİK ALMA CİHAZI



KOD	EN (mm)	BOY (mm)	YÜKSEKLİK (mm)	GİRİŞ VOLTAJI	FİYAT USD
C010-000	120	165	90	220V	

HASSAS SU TERAZİSİ

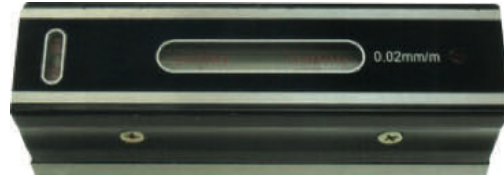

KOD	BOY (mm)	GENİŞLİK (mm)	YÜKSEKLİK (mm)	HASSASİYET (mm)	FİYAT USD
C620-100	100	30	35	0,02	
C620-150	150	42	44	0,02	
C620-200	200	42	44	0,02	
C620-250	250	42	44	0,02	
C620-300	300	42	44	0,02	

HASSAS KARE SU TERAZİSİ



KOD	BOY (mm)	GENİŞLİK (mm)	YÜKSEKLİK (mm)	HASSASİYET (mm)	FİYAT USD
C621-100	100	30	100	0,02	
C621-150	150	37	150	0,02	
C621-200	200	37	200	0,02	
C621-250	250	37	250	0,02	
C621-300	300	37	300	0,02	

DİJİTAL AÇI ÖLÇER (MIKNATISLI TABAN)



MIKNATISLI TABAN

KOD	BOY (mm)	GENİŞLİK (mm)	YÜKSEKLİK (mm)	HASSASİYET (mm)	FİYAT USD
C620-150D	150	31	60	0-10°	

MEKANİK KUMPAKLAR

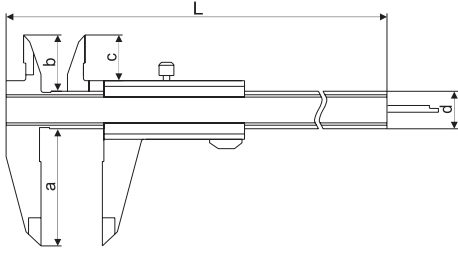

KOD	ÖLÇÜ (mm)	HASSASİYET (mm)	TOLERANS (mm)	L (mm)	a (mm)	b (mm)	c (mm)	d (mm)	FİYAT USD
C100-0105	0-100	0,05	±0,05	160	30	17	13,5	12	
C100-1502	0-150	0,02	±0,03	228	40	21	16,5	16	
C100-1505	0-150	0,05	±0,05	228	40	21	16,5	16	
C100-2002	0-200	0,02	±0,03	299	46	23,5	18,5	16	
C100-2005	0-200	0,05	±0,05	299	46	23,5	18,5	16	
C100-3002	0-300	0,02	±0,04	414	61	26,5	21	17	
C100-3005	0-300	0,05	±0,06	414	61	26,5	21	17	

EKONOMİK TİP MEKANİK KUMPAKLAR

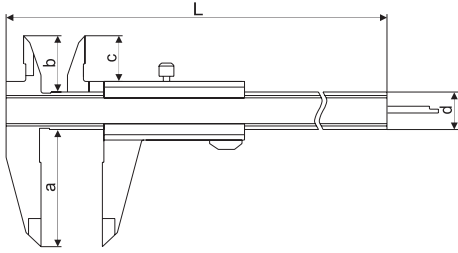

KOD	ÖLÇÜ (mm)	HASSASİYET (mm)	TOLERANS (mm)	L (mm)	a (mm)	b (mm)	c (mm)	d (mm)	FİYAT USD
C100-1502E	0-150	0,02	±0,03	228	40	21	16,5	16	
C100-1505E	0-150	0,05	±0,05	228	40	21	16,5	16	
C100-2002E	0-200	0,02	±0,03	299	46	23,5	18,5	16	
C100-3002E	0-300	0,02	±0,04	414	61	26,5	21	17	

MONOBLOK MEKANİK KUMPAKLAR

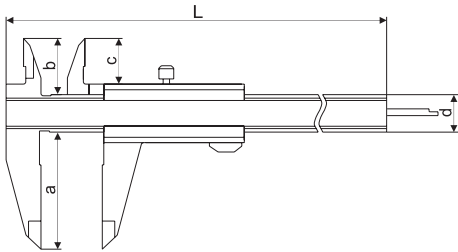

KOD	ÖLÇÜ (mm)	HASSASİYET (mm)	TOLERANS (mm)	L (mm)	a (mm)	b (mm)	c (mm)	d (mm)	FİYAT USD
C100-1502M	0-150	0,02	±0,03	228	40	21	16,5	16	
C100-1505M	0-150	0,05	±0,03	228	40	21	16,5	16	
C100-2002M	0-200	0,02	±0,03	299	46	23,5	18,5	16	
C100-3002M	0-300	0,02	±0,04	414	46	26,5	21	17	

EKONOMİK TİP MEKANİK KUMPAK TEK ÇENE

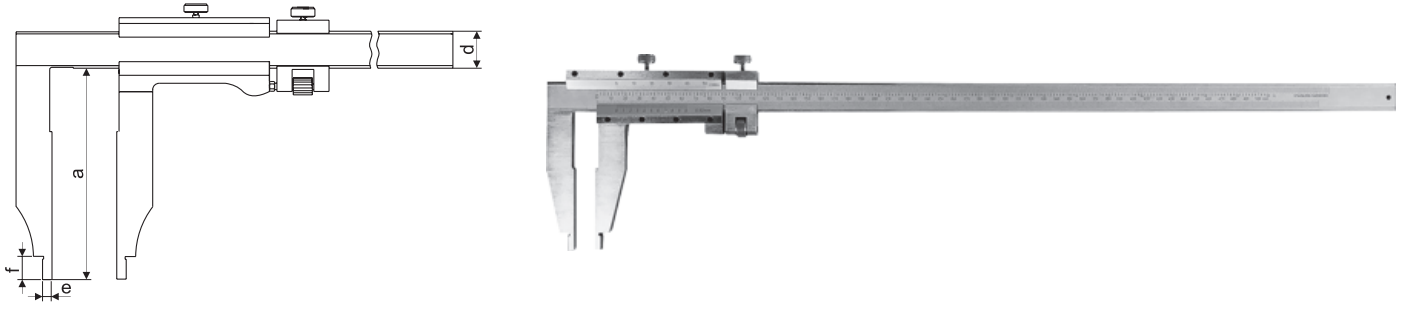

KOD	ÖLÇÜ (mm)	HASSASİYET (mm)	TOLERANS (mm)	a (mm)	d (mm)	e (mm)	f (mm)	FİYAT USD
C100-4002E	0-400	0,02	±0,05	100	25	4,2	12	
C100-5002E	0-500	0,02	±0,05	100	25	5	13	
C100-6002E	0-600	0,02	±0,05	100	25	5	13	
C100-8002E	0-800	0,02	±0,05	125	32	10	17,5	
C100-8002E	0-800	0,02	±0,05	150	32	10	17,5	
C100-10002E	0-1000	0,02	±0,07	125	32	10	20	

EKONOMİK TİP MEKANİK UZUN TEK ÇENE KUMPAK



KOD	ÖLÇÜ (mm)	HASSASİYET (mm)	TOLERANS (mm)	a (mm)	d (mm)	e (mm)	f (mm)	FİYAT USD
C100-3005X90E	0-300	0,05	±0,08	90	17	5	10	
C100-5005X150E	0-500	0,05	±0,08	150	25	5	11	
C100-6005X150E	0-600	0,05	±0,10	150	25	5	11	
C100-10005X200E	0-1000	0,05	±0,10	200	32	10	20	
C100-15005X200E	0-1500	0,05	±0,13	200	42	10	20	
C100-20005X200E	0-2000	0,05	±0,16	200	42	10	20	
C100-30005X200E	0-3000	0,05	±0,26	200	50	10	20	
C100-35005X200E	0-3500	0,05	±0,34	200	50	10	20	
C100-40005X200E	0-4000	0,05	±0,34	200	50	10	20	

MONOBLOK MEKANİK KUMPA S TEK ÇENE

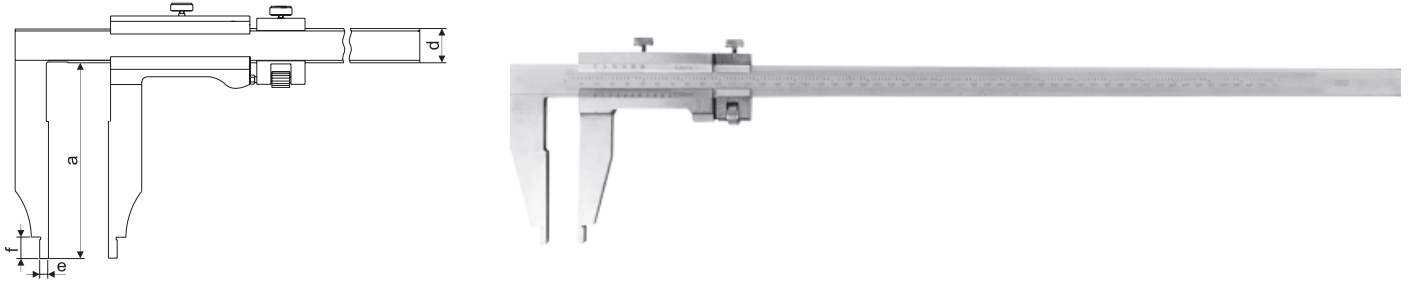

KOD	ÖLÇÜ (mm)	HASSASİYET (mm)	TOLERANS (mm)	a (mm)	d (mm)	e (mm)	f (mm)	FİYAT USD
C100-5002M	0-500	0,02	±0,05	100	25	5	13	
C100-6002M	0-600	0,02	±0,05	100	25	5	13	
C100-10002M	0-1000	0,02	±0,07	125	32	10	20	

EKONOMİK TİP MEKANİK EKSTRA UZUN ÇİFT ÇENE KUMPA S



KOD	ÖLÇÜ (mm)	HASSASİYET (mm)	TOLERANS (mm)	a (mm)	b (mm)	d (mm)	e (mm)	f (mm)	FİYAT USD
C100-3002X150E	0-300	0,02	±0,04	150	43	20	5	11,5	
C100-5002X125E	0-500	0,02	±0,05	125	62	25	5,25	12,5	
C100-5002X150E	0-500	0,02	±0,05	150	62	25	5,25	12,5	
C100-5002X250E	0-500	0,02	±0,05	250	62	25	5,25	12,5	
C100-6002X125E	0-600	0,02	±0,05	125	62	25	5,25	12,5	
C100-6002X300E	0-600	0,02	±0,05	300	62	25	5,25	12,5	
C100-10002X125E	0-1000	0,02	±0,07	125	72	32	10	24	
C100-10002X150E	0-1000	0,02	±0,07	150	72	32	10	24	
C100-10002X500E	0-1000	0,02	±0,07	500	72	32	10	24	

EKONOMİK TİP MEKANİK DERİNLİK KUMPASI

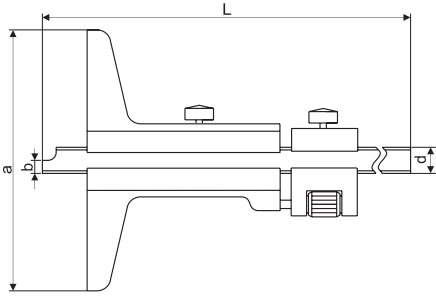

KOD	ÖLÇÜ (mm)	HASSASİYET (mm)	TOLERANS (mm)	L (mm)	a (mm)	b (mm)	d (mm)	FİYAT USD
C103-1502E	0-150	0,02	±0,03	227	100	4	8,5	
C103-2002E	0-200	0,02	±0,03	327	100	4	8,5	
C103-3002E	0-300	0,02	±0,04	377	100	4	8,5	
C103-5002E	0-500	0,02	±0,05	577	100	4	8,5	

SAATLİ KUMPAŞ

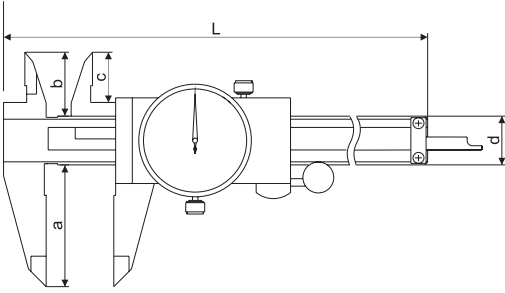

KOD	ÖLÇÜ (mm)	HASSASİYET (mm)	L (mm)	a (mm)	b (mm)	c (mm)	d (mm)	FİYAT USD
C101-1502S	0-150	0,02	232	40	21	16,5	16	
C101-2002S	0-200	0,02	295	50	24	18,5	16	
C101-3002S	0-300	0,02	415	57	28	22	17	

3 AĞIZLI KUMPAŞ



ÜÇ KÖŞELİ CİSİMLERİN (ÜÇ AĞIZLI KILAVUZ V.B) ÖLÇÜMÜNDE KULLANILIR.

KOD	ÖLÇÜ(mm)	HASSASİYET (mm)	FİYAT USD
C103-3FL-0440	4-40	0,05	
C103-3FL-2075	20-75	0,05	

KAYNAKÇI KUMPASI

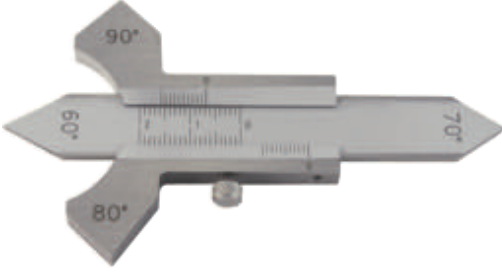

KOD	ÖLÇÜ (mm)	HASSASİYET (mm)	DERECE	FİYAT USD
C107-020	0-20	0,1	60-70-80-90°	

ÇOK AMAÇLI KAYNAKÇI KUMPASI

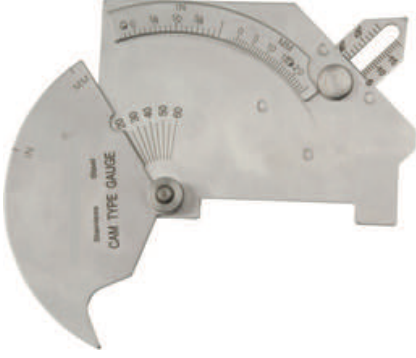

KOD	FİYAT USD
C107-021	

HI-LO CAT#1 KAYNAK KUMPASI



KOD	FİYAT USD
C107-023	

ARALIK MASTARI

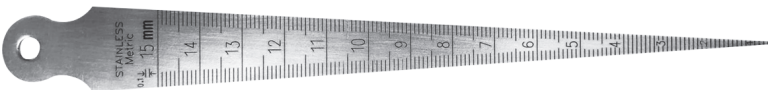

KOD	ÖLÇÜ (mm)	FİYAT USD
C107-022	150	

MANYETİK GÖNYE KAYNAK TUTUCU (4' LÜ SET)

AVANTAJLARI :

- AÇI DERESESİNİN EN POPÜLER KULLANIM ŞEKLİ
- GÜVENLİKLİ VE VERİMLİ
- EL KULLANIMI OLMADAN KULLANILAN KAYNAK AKSESUARİ



KULLANIM ALANLARI :

- KAYNAK, MONTAJ, LEHİMLEME, BORU TESİSATI, BAĞLANTI KURMA, YÜZEY TAŞLAMA, SÜSPANSİYON UYGULAMALARI VE DİĞER KÖŞELİ AYRAÇLA YAPILAN YÜKSEK SICAKLIK UYGULAMALARI



KOD	NO	AÇI	Max. TAŞIMA GÜCÜ (lb)	FİYAT USD
C107-026	NO. 1	45° - 90° - 135°	10lb	
	NO. 2	45° - 90°	25lb	

MATKAP AÇI MASTARI

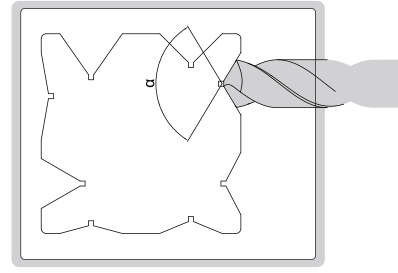
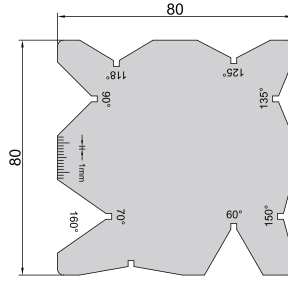

KOD	ÖLÇÜ DERECELERİ	TOLERANS	FİYAT USD
C107-024	60° - 82° - 90° - 118° - 120° - 135° - 150° - 160°	±0,5°	

ÇOK AMAÇLI ÖLÇÜ MASTARI

KOD	BOYUT (mm)	FİYAT USD
C107-025	170x90x1	

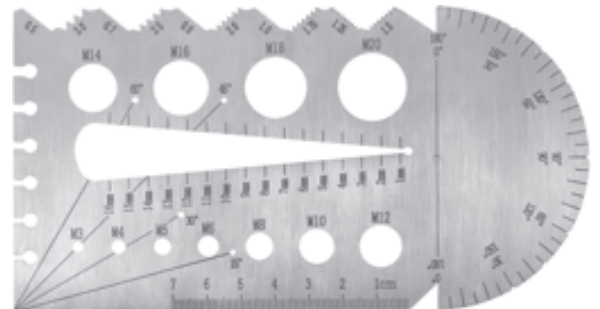

EKONOMİK TİP DİJİTAL KUMPAKLAR

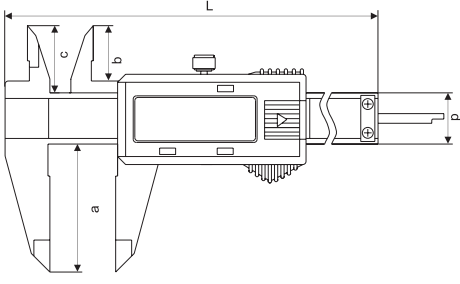

KOD	ÖLÇÜ (mm)	HASSASİYET (mm)	TOLERANS (mm)	L (mm)	a (mm)	b (mm)	c (mm)	d (mm)	FİYAT USD
C102-1001E	0-100	0,01	±0,03	170	30	16,5	12	13	
C102-1501E	0-150	0,01	±0,03	236	41	21	16,5	16	
C102-2001E	0-200	0,01	±0,03	288	50	24	19,5	16	
C102-3001E	0-300	0,01	±0,03	400	60	25	20,5	17	

METALİK TİP DİJİTAL KUMPAKLAR

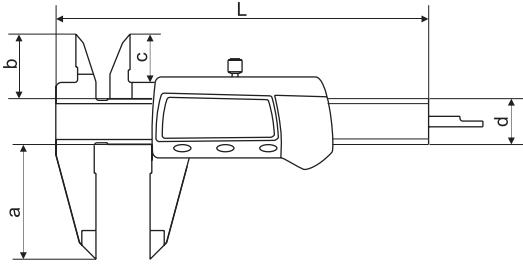

KOD	ÖLÇÜ (mm)	HASSASİYET (mm)	TOLERANS (mm)	L (mm)	a (mm)	b (mm)	c (mm)	d (mm)	FİYAT USD
C102-1501MTL	0-150	0,01	±0,03	236	41	21	16,5	16	
C102-2001MTL	0-200	0,01	±0,03	288	50	24	19,5	16	
C102-3001MTL	0-300	0,01	±0,04	400	60	25	20,5	17	

KARBON FİBER DİJİTAL KUMPAKLAR

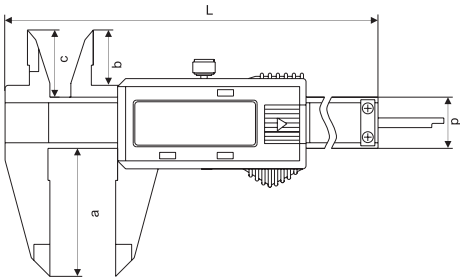

KOD	ÖLÇÜ (mm)	HASSASİYET (mm)	L (mm)	a (mm)	b (mm)	c (mm)	d (mm)	FİYAT USD
C102-1501P	0-150	0,1	236	41	21	16,5	16	

EKONOMİK TİP DİJİTAL KUMPAS BÜYÜK EKРАН

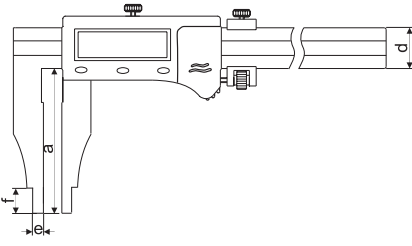

KOD	ÖLÇÜ (mm)	HASSASİYET (mm)	TOLERANS (mm)	a (mm)	d (mm)	e (mm)	f (mm)	FİYAT USD
C102-5001E	0-500	0,01	±0,05	100	24	5	12	
C102-6001E	0-600	0,01	±0,05	100	24	5	12	
C102-8001E	0-800	0,01	±0,06	150	31	10	23,5	
C102-10001E	0-1000	0,01	±0,07	200	32	10	17	
C102-15001E	0-1500	0,01	±0,07	200	41,5	10	20	
C102-20001E	0-2000	0,01	±0,07	200	41,5	10	20	

DİJİTAL KUMPAS UZUN ÇİFT ÇENE

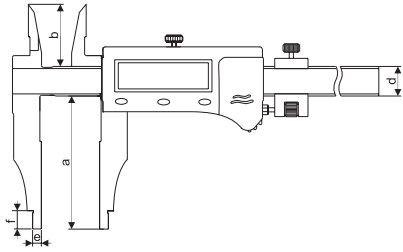

KOD	ÖLÇÜ (mm)	HASSASİYET (mm)	TOLERANS (mm)	a (mm)	b (mm)	d (mm)	e (mm)	f (mm)	FİYAT USD
C102-3001X90	0-300	0,01	±0,04	90	26	17	5	10,5	
C102-5001X125	0-500	0,01	±0,05	125	45	25	5	12	
C102-5001X150	0-500	0,01	±0,05	150	45	25	5	12	
C102-6001X125	0-600	0,01	±0,05	125	45	25	5	12	
C102-6001X150	0-600	0,01	±0,05	150	45	25	5	12	
C102-10001X150	0-1000	0,01	±0,07	150	52	32	10	17.5	

DİJİTAL DIŞ DERİNLİK KUMPASI

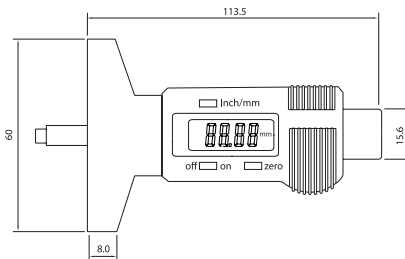

KOD	ÖLÇÜ (mm)	HASSASİYET (mm)	ÇALIŞMA SICAKLIĞI	FİYAT USD
C108-0254	0-25,4	0,01	0-40°	

EKONOMİK TİP İÇ KANAL DİJİTAL KUMPAS

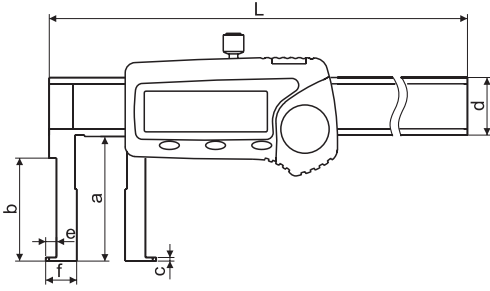

KOD	ÖLÇÜ (mm)	HASSASİYET (mm)	TOLERANS (mm)	L (mm)	a (mm)	b (mm)	c (mm)	d (mm)	e (mm)	f (mm)	FİYAT USD
C109-2017E	20-170	0,01	±0,04	240	40	25	1	16	3	10	
C109-2522E	25-225	0,01	±0,04	295	50	35	1.2	16	4	12.5	
C109-3033E	30-330	0,01	±0,05	450	60	45	1.6	17	5	15	

EKONOMİK TİP DIŞ KANAL DİJİTAL KUMPAS

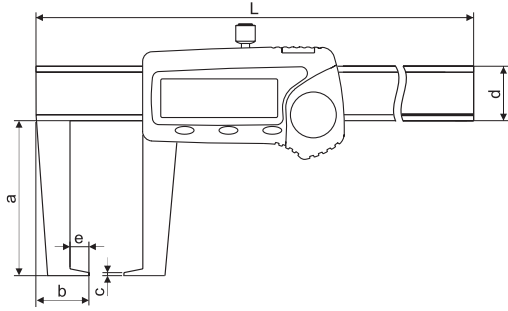

KOD	ÖLÇÜ (mm)	HASSASİYET (mm)	TOLERANS (mm)	L (mm)	a (mm)	b (mm)	c (mm)	d (mm)	e (mm)	FİYAT USD
C109-0015E	0-150	0,01	±0,03	240	40	12	1,4	16	5	
C109-0020E	0-200	0,01	±0,03	295	50	15,5	1.8	16	8.5	
C109-0030E	0-300	0,01	±0,03	450	60	17,5	1,4	17	10	

EKONOMİK TİP DİJİTAL DERİNLİK KUMPAS

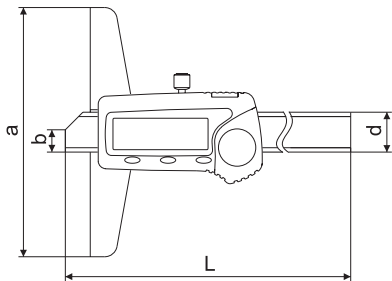

KOD	ÖLÇÜ (mm)	HASSASİYET (mm)	TOLERANS (mm)	L (mm)	a (mm)	b (mm)	d (mm)	FİYAT USD
C108-1501E	0-150	0,01	±0,03	245	103	11	15,5	
C108-2001E	0-200	0,01	±0,03	295	103	11	15,5	
C108-3001E	0-300	0,01	±0,04	395	103	11	15,5	

EKONOMİK TİP MEKANİK DIŞ ÇAP MİKROMETRESİ

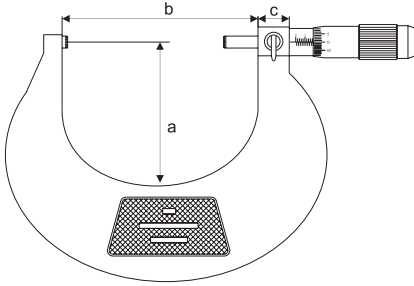

KOD	ÖLÇÜ (mm)	HASSASİYET (mm)	TOLERANS (mm)	a (mm)	b (mm)	c (mm)	FİYAT USD
C200-00025E	0-25	0,01	±0,004	29	32	17	
C200-02550E	25-50	0,01	±0,004	43	57	17	
C200-05075E	50-75	0,01	±0,005	55	81	17	
C200-07510E	75-100	0,01	±0,005	65	117	17	
C200-1012E	100-125	0,01	±0,006	65	132	17	
C200-1215E	125-150	0,01	±0,006	80	155	17	
C200-1517E	150-175	0,01	±0,007	91	180	17	
C200-1720E	175-200	0,01	±0,007	103	206	17	
C200-2022E	200-225	0,01	±0,008	125	232	17	
C200-2225E	225-250	0,01	±0,008	135	256	17	
C200-2527E	250-275	0,01	±0,009	145	282	17	
C200-2730E	275-300	0,01	±0,009	160	298	17	
C200-3040E	300-400	0,01	±0,011	220	407	17	
C200-4050E	400-500	0,01	±0,013	275	510	17	
C200-5060E	500-600	0,01	±0,015	330	610	17	
C200-6070E	600-700	0,01	±0,016	390	710	31	
C200-7080E	700-800	0,01	±0,018	440	810	31	
C200-8090E	800-900	0,01	±0,020	492	910	31	
C200-9010E	900-1000	0,01	±0,020	545	1010	31	
C200-100120E	1000-1200	0,01	±0,022	595	1210	31	
C200-120140E	1200-1400	0,01	±0,024	645	1410	31	
C200-140160E	1400-1600	0,01	±0,026	695	1610	31	

EKONOMİK TİP DİJİTAL DIŞ ÇAP MİKROMETRESİ

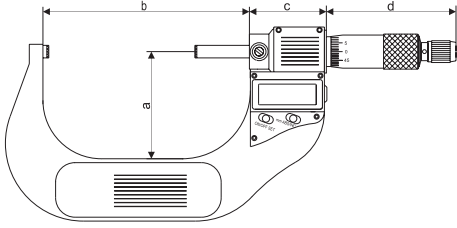

KOD	ÖLÇÜ (mm)	HASSASİYET (mm)	TOLERANS (mm)	a (mm)	b (mm)	c (mm)	d (mm)	FİYAT USD
C204-0025E	0-25	0,001	±0,004	23	33	65	45	
C204-2550E	25-50	0,001	±0,004	30	58	65	45	
C204-5075E	50-75	0,001	±0,004	43	83	65	45	
C204-7510E	75-100	0,001	±0,004	55	105	65	45	

EKONOMİK TİP MEKANİK İÇ ÇAP MİKROMETRESİ

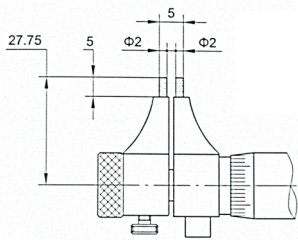

5-30 mm İÇİN

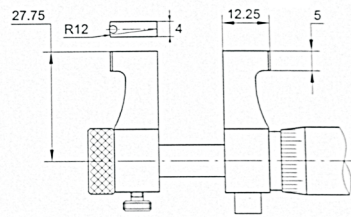

25-50....175-200 mm İÇİN



KOD	ÖLÇÜ (mm)	HASSASİYET (mm)	TOLERANS (mm)	ÖLÇME KUVVETİ	ADIM (mm)	FİYAT USD
C201-0530E	5-30	0,01	±0,005	5-10	0,5	
C201-2550E	25-50	0,01	±0,006	5-10	0,5	
C201-5075E	50-75	0,01	±0,007	5-10	0,5	
C201-7510E	75-100	0,01	±0,008	5-10	0,5	

KALINLIK MİKROMETRESİ

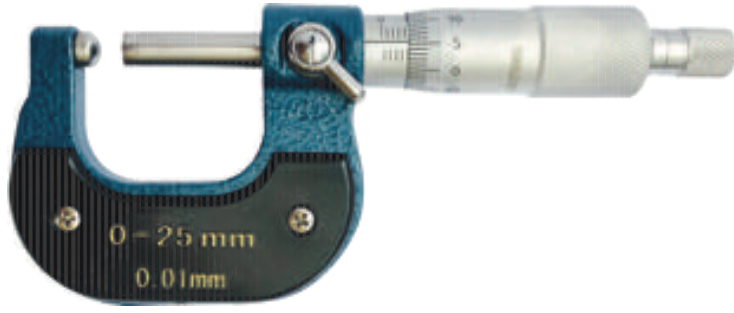

KOD	ÖLÇÜ (mm)	HASSASİYET (mm)	FİYAT USD
C207-HC21	0-25	0,01	

SAC MİKROMETRESİ



KOD	ÖLÇÜ (mm)	HASSASİYET (mm)	ÖLÇÜ MİLİ (mm)	FİYAT USD
C207-BC01	0-15	0,01	6,35	

VİDA MİKROMETRESİ



İÇİNDEKİ ÖLÇÜLER	
METRİK Hatve	UNF Diş/inch
0,4 - 0,5	64,0 - 48,0
0,6 - 0,90	44,0 - 28,0
1,0 - 1,75	24,0 - 14,0
2,0 - 3,0	13,0 - 9,0
3,5 - 5,0	8,0 - 5,0

KOD	ÖLÇÜ (mm)	HASSASİYET (mm)	ÖLÇÜ MİLİ (mm)	FİYAT USD
C205-0025	0-25	0,01	6,35	
C205-2550	25-50	0,01	6,35	
C205-5075	50-75	0,01	6,35	

EKONOMİK TİP MEKANİK DERİNLİK MİKROMETRESİ

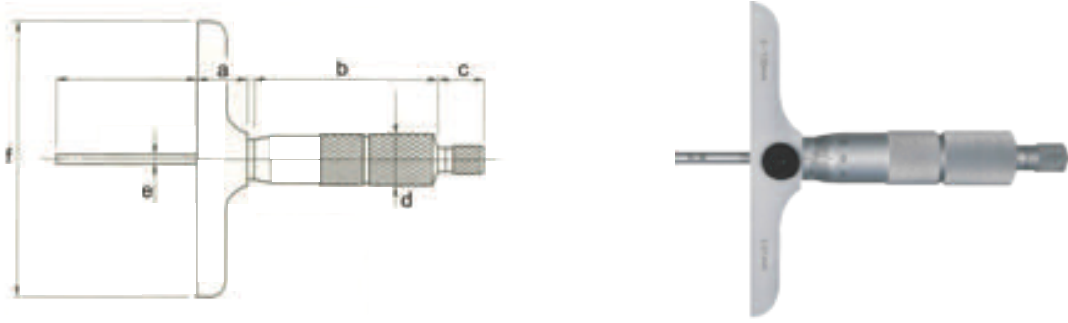

KOD	ÖLÇÜ (mm)	HASSASİYET (mm)	a (mm)	b (mm)	c (mm)	d (mm)	e (mm)	f (mm)	UÇ SAYISI	FİYAT USD
C202-0100E	0-100	0,01	17	70	19	18	4	100	4	
C202-0150E	0-150	0,01	17	70	19	18	4	100	6	
C202-0200E	0-200	0,01	17	70	19	18	4	100	8	
C202-0300E	0-300	0,01	17	70	19	18	4	100	12	

PASİMETRE



KOD	ÖLÇÜ (mm)	HASSASİYET (mm)	FİYAT USD
C206-0025	0-25	0,001	

MİKROMETRE STANDI

KOD	ÖLÇÜ (mm)	FİYAT USD
C208-000	0-100 mm MİKROMETRELER İÇİN	



ALÜMİNYUM GÖVDE

EKONOMİK TİP MEKANİK MİKROMETRE SETİ

KOD	ÖLÇÜ (mm)	FİYAT USD
C209-0150E	0-150 mm MİKROMETRE 6 PARÇA	
C209-0300E	0-300 mm MİKROMETRE 12 PARÇA	



MEKANİK İÇ ÇAP BORU MİKROMETRESİ

KOD	ÖLÇÜ (mm)	HASSASİYET (mm)	FİYAT USD
C197-50300	50-300	0,01	
C197-50600	50-600	0,01	
C197-501000	50-1000	0,01	
C197-501500	50-1500	0,01	
C197-102100	100-2100	0,01	



MEKANİK ÜÇ NOKTA TEMASLI MİKROMETRE SETİ



KOD	ÖLÇÜ (mm)	HASSASİYET (mm)	SET ADETİ	İÇİNDEKİ ÖLÇÜLER (mm)	FİYAT USD
C198-0612	6-12	0,004	3	6-8 , 8-10 , 10-12	
C198-1220	12-20	0,004	2	12-16 , 16-20	
C198-2050	20-50	0,004	4	20-25 , 25-30 , 30-40 , 40-50	
C198-50100	50-100	0,005	4	50-63 , 62-75 , 75-88 , 87-100	

EKONOMİK TİP KOMPARATÖR SAATİ

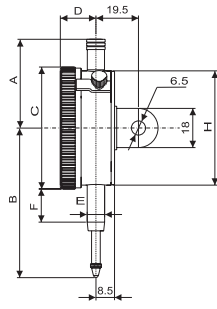

**KULAKLI VE KULAKSIZ
OLARAK KULLANILABİLİR.**

KOD	ÖLÇÜ (mm)	HASSASİYET (mm)	A (mm)	B (mm)	ØC (mm)	D (mm)	E (mm)	F (mm)	H (mm)	FİYAT USD
C400-1001E	0-10	0,01	42	74	57	27,5	8	22	54	
C400-2501E	0-25	0,01	85	86	57	27,5	8	22	54	
C400-3001E	0-30	0,01	85	90	57	27,5	8	22	54	
C400-5001E	0-50	0,01	120	138	57	27,5	8	22	54	
C400-10001E	0-100	0,01	205	205	80	16,5	8	57	76	

EKONOMİK TİP KÜÇÜK ÇAP KOMPARATÖR SAATİ

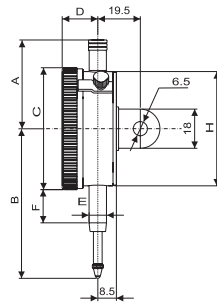

**KULAKLI VE KULAKSIZ
OLARAK KULLANILABİLİR.**

KOD	ÖLÇÜ (mm)	HASSASİYET (mm)	A (mm)	B (mm)	ØC (mm)	D (mm)	E (mm)	F (mm)	H (mm)	FİYAT USD
C400-0501KC	0-5	0,01	33	57	42	12	8	18	38	
C400-1001KCE	0-10	0,01	33	57	42	12	8	18	38	

DİJİTAL KOMPARATÖR SAATİ

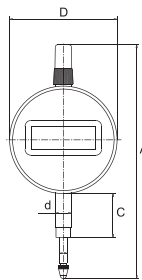

KOD	ÖLÇÜ (mm)	HASSASİYET (mm)	TOLERANS	A (mm)	B (mm)	C (mm)	D (mm)	d (mm)	FİYAT USD
C401-0127	0-12,7	0,01	7 µm	120	25	21	Ø56	Ø8	

EKONOMİK TİP SALGI KOMPARATÖR SAATİ

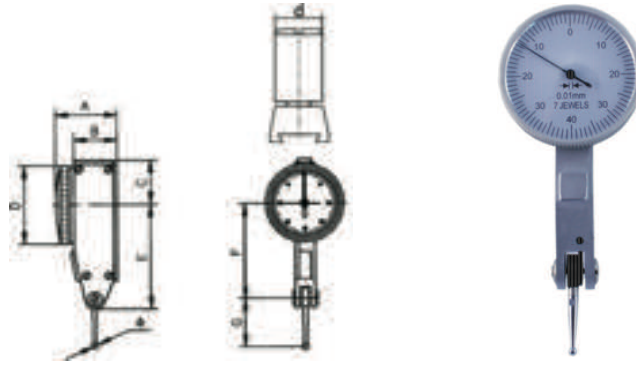

KOD	ÖLÇÜ (mm)	HASSASİYET (mm)	TOLERANS	A (mm)	B (mm)	C (mm)	D (mm)	E (mm)	F (mm)	d (mm)	G (mm)	Ø (mm)	FİYAT USD
C500-0801E	0-0,8	0,01	7-10 µm	24	17,3	16,5	Ø31	42,7	38,7	4/8	19	2,5	
C500-0202E	0-0,2	0,002	3 µm	24	17,3	16,5	Ø31	42,7	38,7	4/8	19	2,5	

CEP TİPİ KALINLIK KOMPARATÖRÜ

KOD	ÖLÇÜ (mm)	HASSASİYET (mm)	ÖLÇME DERİNLİĞİ (mm)	FİYAT USD
C207-010	0-10	0,01	15	
C207-020	0-20	0,01	15	



EKONOMİK TİP SİLİNDİR KOMPARATÖRÜ

KOD	ÖLÇÜ (mm)	HASSASİYET (mm)	TOLERANS	L (mm)	FİYAT USD
C300-0610E	6-10	0,01	12 µm	57	
C300-1018E	10-18	0,01	12 µm	106	
C300-1835E	18-35	0,01	15 µm	150	
C300-3550E	35-50	0,01	18 µm	150	
C300-5016E	50-160	0,01	18 µm	150	
C300-1625E	160-250	0,01	18 µm	415	
C300-2545E	250-450	0,01	18 µm	415	

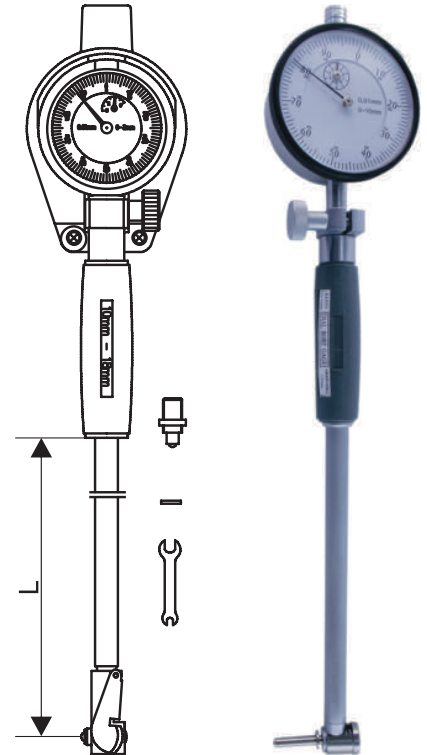

KALINLIK KOMPARATÖRÜ

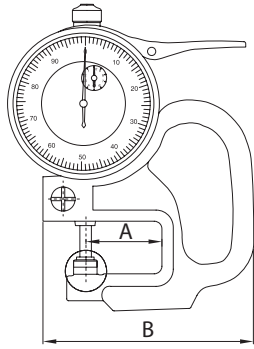

KOD	ÖLÇÜ (mm)	HASSASİYET (mm)	A (mm)	B (mm)	FİYAT USD
C207-LD18	0-10	0,01	30	85	
C207-LD19	0-10	0,01	120	202	

RULMANLI KALINLIK KOMPARATÖRÜ

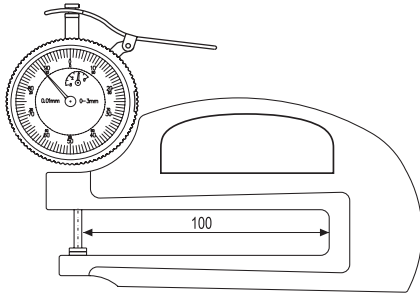

KOD	ÖLÇÜ (mm)	HASSASİYET (mm)	ÖLÇME DERİNLİĞİ (mm)	FİYAT USD
C207-LD17	0-10	0,01	100	

BORU KOMPARATÖRÜ



KOD	ÖLÇÜ (mm)	HASSASİYET (mm)	ÖLÇME DERİNLİĞİ (mm)	FİYAT USD
C207-LD12	0-10	0,01	30	

SAATLİ İÇ ÇAP KOMPARATÖRÜ

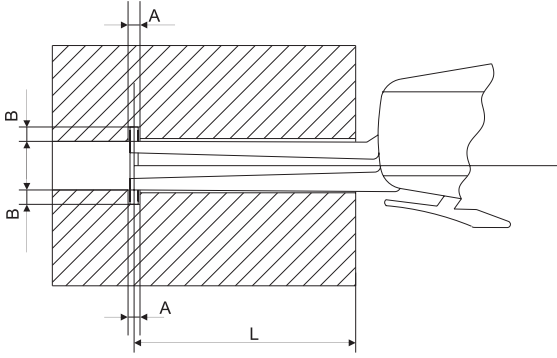

KOD	ÖLÇÜ (mm)	HASSASİYET (mm)	A (mm)	B (mm)	L (mm)	FİYAT USD
C099-1535	15-35	0,01	2,5	3	65	
C099-3555	35-55	0,01	6	3	72	
C099-5575	55-75	0,01	8	3	72	
C099-7595	75-95	0,01	8	3	74	
C099-95115	95-115	0,01	10	3,5	105	
C099-115135	115-135	0,01	10	3,5	105	

DİJİTAL İÇ ÇAP KOMPARATÖRÜ

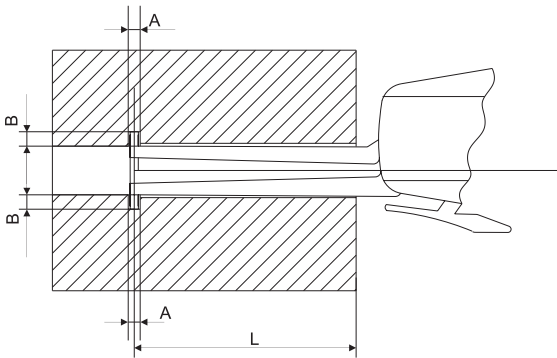

KOD	ÖLÇÜ (mm)	HASSASİYET (mm)	TOLERANS	A (mm)	B (mm)	L (mm)	FİYAT USD
C097-0525	5-25	0,005	±0,03	2,15	3	80	
C097-2040	20-40	0,005	±0,03	6,35	3,25	85	
C097-4060	40-60	0,005	±0,03	9	3,25	85	

SAATLİ DIŞ ÇAP KOMPARATÖRÜ

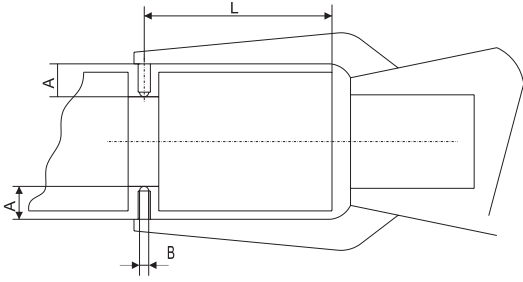

KOD	ÖLÇÜ (mm)	HASSASİYET (mm)	A (mm)	B (mm)	L (mm)	FİYAT USD
C098-0020	0-20	0,01	5,75	3	70	
C098-2040	20-40	0,01	5,75	3	75	
C098-4060	40-60	0,01	5,75	3	75	
C098-6080	60-80	0,01	5,75	3	75	
C098-80100	80-100	0,01	5,75	3	75	

DİJİTAL DIŞ ÇAP KOMPARATÖRÜ

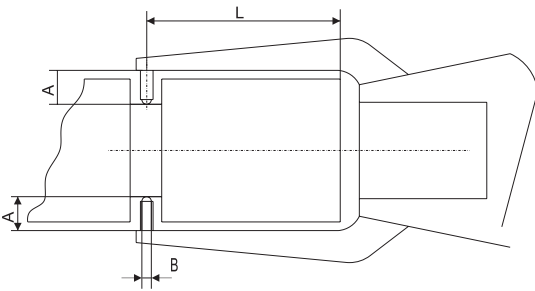

KOD	ÖLÇÜ (mm)	HASSASİYET (mm)	TOLERANS	A (mm)	B (mm)	L (mm)	FİYAT USD
C096-0020	0-20	0,005	±0,03	23,5	6,3	85	
C096-2040	20-40	0,005	±0,03	25	6,3	85	
C096-4060	40-60	0,005	±0,03	25	6,3	85	

DİJİTAL YÜKSEKLİK MİHENGİRİ

KOD	ÖLÇÜ (mm)	HASSASİYET (mm)	TOLERANS (mm)	TİPİ	FİYAT USD
C105-300	0-300	0,01	± 0,02	ÇİFT KOLON	
C105-500	0-500	0,01	± 0,04	ÇİFT KOLON	
C105-600	0-600	0,01	± 0,04	ÇİFT KOLON	
C105-1000	0-1000	0,01	± 0,06	TEK KOLON	



MERCEKLİ YÜKSEKLİK MİHENGİRİ

KOD	ÖLÇÜ (mm)	HASSASİYET (mm)	TOLERANS (mm)	FİYAT USD
C104-3002	0-300	0,02	± 0,04	
C104-5002	0-500	0,02	± 0,05	
C104-6002	0-600	0,02	± 0,05	
C104-10002	0-1000	0,02	± 0,07	



SAATLİ YÜKSEKLİK MİHENGİRİ

KOD	ÖLÇÜ (mm)	HASSASİYET (mm)	TOLERANS (mm)	FİYAT USD
C106-300	0-300	0,01	± 0,03	
C106-500	0-500	0,01	± 0,05	



DERECELİ ÇELİK MASTAR



KOD	BOY (mm)	GENİŞLİK (mm)	KALINLIK (mm)	FİYAT USD
C111-0500	500	25	5	
C111-0750	750	30	6	
C111-1000	1000	30	6	
C111-1500	1500	30	6	
C111-2000	2000	40	8	
C111-2500	2500	40	8	
C111-3000	3000	40	8	
C111-4000	4000	40	8	

PASLANMAZ ÇELİK CETVEL MM/INCH

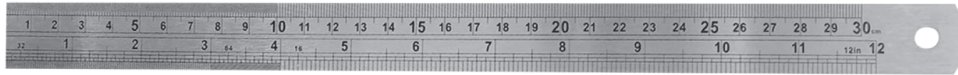

KOD	BOY (mm)	GENİŞLİK (mm)	KALINLIK (mm)	FİYAT USD
C110-01515	150	15	0,50	
C110-02020	200	20	0,75	
C110-03025	300	25	0,70	
C110-05030	500	30	0,85	
C110-10020	1000	20	0,70	
C110-10030	1000	30	0,95	
C110-15038	1500	38	1,40	
C110-20038	2000	38	1,70	

DİJİTAL DOĞRUSAL CETVEL

ÖZELLİKLER

- İŞLEME TEZGAHLARINDA İŞLEMLERİN YÜKSEK HASSASİYETLE YAPILMASINI SAĞLAR. MATKAP, FREZE MAKİNALARINA KOLAYCA MONTE EDİLEBİLİR. GENİŞ LCD EKRAANI VARDIR. ALÜMİNYUM ALAŞIMLI ÇUBUĞU KEŞİLEREK HER TÜRLÜ POZİSYONA VE ÖZEL MAKİNAYA MONTE EDİLEBİLİR. DEĞİŞİK SABİTLEME SEÇENEKLERİ OLARAK, MIKNATIS, ASMA DELİĞİ VE SABİTLEME PLAKASI VARDIR.



KOD	BOY (mm)	HASSASİYET (mm)	FİYAT USD
C110D-0600	600	0,01	
C110D-1000	1000	0,01	

YATAY DİJİTAL DOĞRUSAL CETVEL

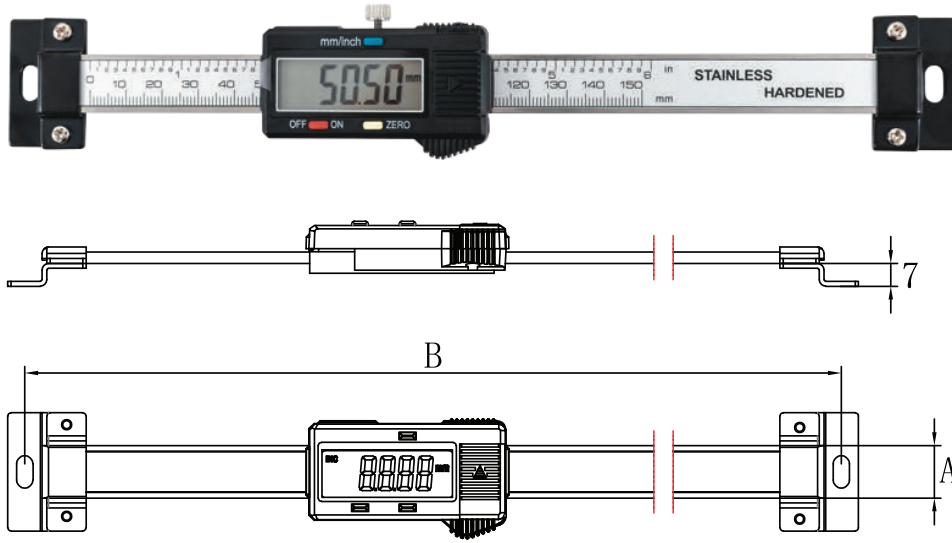

KOD	ÖLÇÜ (mm)	HASSASİYET (mm)	TOLERANS (mm)	A (mm)	B (mm)	FİYAT USD
C112-150	0-150	0,01	±0,03	16	251	
C112-200	0-200	0,01	±0,03	16	303	
C112-300	0-300	0,01	±0,04	16	433	

DİKEY DİJİTAL DOĞRUSAL CETVEL

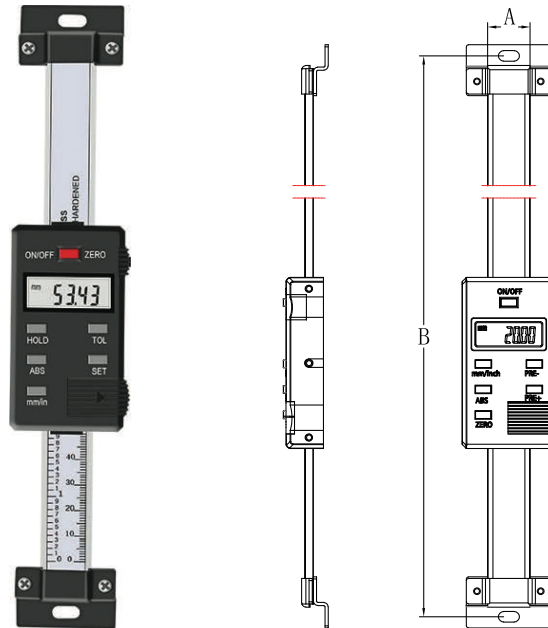

KOD	ÖLÇÜ (mm)	HASSASİYET (mm)	TOLERANS (mm)	A (mm)	B (mm)	FİYAT USD
C113-150	0-150	0,01	±0,03	20	280	
C113-200	0-200	0,01	±0,03	20	330	
C113-300	0-300	0,01	±0,04	20	430	

ŞAPKALI GÖNYE DIN 875/2

KOD	BOYUT (mm)	FİYAT USD
C127-050040	50x40	
C127-075050	75x50	
C127-100070	100x70	
C127-150100	150x100	
C127-200130	200x130	
C127-250165	250x165	
C127-300175	300x175	
C127-400230	400x230	
C127-500280	500x280	



EKONOMİK TİP ŞAPKALI GÖNYE

KOD	BOYUT (mm)	FİYAT USD
C127-100070E	100x70	
C127-150100E	150x100	
C127-200130E	200x130	
C127-250165E	250x165	
C127-300175E	300x175	
C127-400230E	400x230	
C127-500280E	500x280	
C127-600400E	600x400	
C127-750500E	750x500	
C127-1000660E	1000x660	



MERKEZLEME GÖNYESİ

KOD	BOY (mm)	UZUNLUK (mm)	FİYAT USD
C119-070	70	100	
C119-130	130	150	
C119-150	150	200	
C119-160	160	250	
C119-180	180	300	

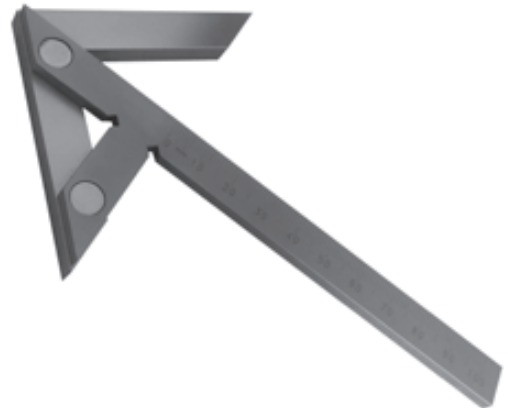

EKONOMİK TİP KIL GÖNYE

KOD	BOYUT (mm)	FİYAT USD
C125-050040E	50x40	
C125-075050E	75x50	
C125-100070E	100x70	
C125-150100E	150x100	
C125-200130E	200x130	
C125-300200E	300x200	



EKONOMİK TİP DÜZ GÖNYE

KOD	BOYUT (mm)	FİYAT USD
C128-050040E	50x40	
C128-075050E	75x50	
C128-100070E	100x70	
C128-150100E	150x100	
C128-200130E	200x130	
C128-250165E	250x165	
C128-300175E	300x175	
C128-400230E	400x230	
C128-500280E	500x280	



AÇILI GÖNYE

KOD	BOY (mm)	UZUNLUK (mm)	FİYAT USD
C120-080	80	120	
C120-120	120	150	
C120-150	150	200	
C120-200	200	300	
C120-300	300	500	

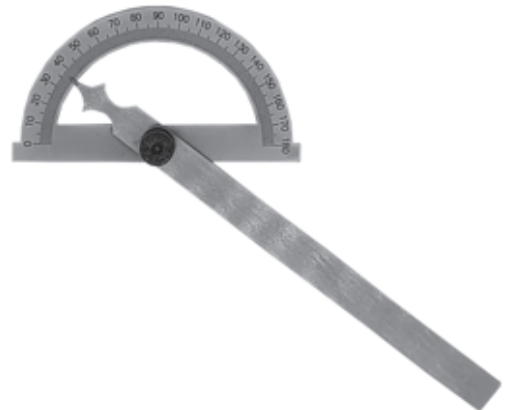

EKONOMİK TİP SAATLİ AÇI ÖLÇER



KOD	ÖLÇÜ	ÖLÇME ÇUBUĞU	ÇUBUK BOYLARI	FİYAT USD
C610-360SE	0-360°	3 ADET	150-200-300 mm	

EKONOMİK TİP DERECELİ MERCEKLİ GÖNYE

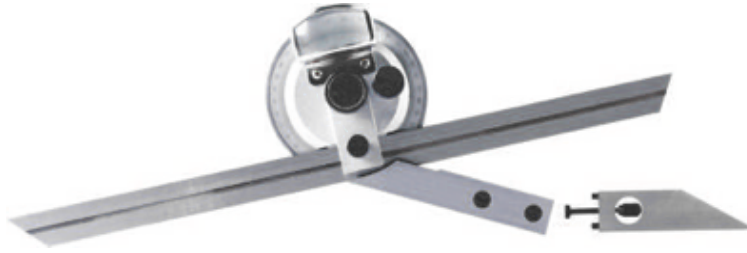

KOD	ÖLÇÜ	ÖLÇME ÇUBUĞU	ÇUBUK BOYLARI	FİYAT USD
C610-360ME	0-360°	3 ADET	150-200-300 mm	

DİJİTAL GÖNYE



KOD	ÖLÇÜ	ÇUBUK BOYLARI	FİYAT USD
C610-360D	0-360°	150-200-300 mm	

YANDAN CİVATALI, KALEM TUTUCULU PERGEL

KOD	ÖLÇÜ (mm)	FİYAT USD
C014-150	150	
C014-200	200	
C014-250	250	
C014-300	300	



DÜZ PERGEL

KOD	ÖLÇÜ (mm)	FİYAT USD
C013-01X075	75	
C013-01X100	100	
C013-01X125	125	
C013-01X200	200	
C013-01X250	250	
C013-01X300	300	
C013-01X400	400	
C013-01X500	500	
C013-01X600	600	



DIŞ ÇAP PERGELİ

KOD	ÖLÇÜ (mm)	FİYAT USD
C013-03X200	200	
C013-03X250	250	
C013-03X300	300	
C013-03X400	400	
C013-03X500	500	
C013-03X600	600	



İÇ ÇAP PERGELİ

KOD	ÖLÇÜ (mm)	FİYAT USD
C013-02X200	200	
C013-02X250	250	
C013-02X300	300	



JOHNSON MASTAR SETİ (103 PARÇA)

KOD	ÖLÇÜ (mm)	FİYAT USD
C327-103-2	1,005-100 mm Gr2	



PARALEL SET



KOD	BOY (mm)	KALINLIK (mm)	ADET	ÖLÇÜLER (mm)	FİYAT USD
C328-7	150	-	7 ÇİFT	6x10-6x12-8x14-12x18-12x24-16x36-16x38	
C328-14X5	150	5	14 ÇİFT	14-16-18-20-22-24-26-28-30-32-35-40-45-50	
C328-14X10	150	10	14 ÇİFT	14-16-18-20-22-24-26-28-30-32-35-40-45-50	

PİM MASTAR SETİ



KOD	ÖLÇÜ (mm)	SET ADETİ	PÜRÜZLÜLÜK	ADIM (mm)	SERTLİK	BOY (mm)	FİYAT USD
C995-091	1-10	91 PARÇA	≤ 0,1µm Ra	0,1	60-62 HRC	50	
C995-273	0,99-10,01	273 PARÇA	≤ 0,1µm Ra	0,1	60-62 HRC	50	

FİLLER ÇAKISI

KOD	ÖLÇÜ (mm)	ADET	FİYAT USD
C320.20	0,05-1,0x100	20 ADET	
C320.20X200	0,05-1,0x200	20 ADET	
C320.20X300	0,05-1,0x300	20 ADET	
C320.20X500	0,05-1,0x500	20 ADET	
C319.26 INCH	0,0015"-0,025"x90	26 ADET	



ŞERİT SENTİL



KOD	HASSASİYET (mm)	EN (mm)	BOY (mm)	FİYAT USD
C318-001	0,01	13	5000	
C318-002	0,02	13	5000	
C318-003	0,03	13	5000	
C318-004	0,04	13	5000	
C318-005	0,05	13	5000	
C318-006	0,06	13	5000	
C318-007	0,07	13	5000	
C318-008	0,08	13	5000	
C318-009	0,09	13	5000	
C318-010	0,10	13	5000	
C318-015	0,15	13	5000	
C318-020	0,20	13	5000	
C318-025	0,25	13	5000	
C318-030	0,30	13	5000	
C318-035	0,35	13	5000	
C318-040	0,40	13	5000	
C318-045	0,45	13	5000	
C318-050	0,50	13	5000	
C318-060	0,60	13	5000	
C318-070	0,70	13	5000	
C318-080	0,80	13	5000	
C318-090	0,90	13	5000	
C318-100	1,00	13	5000	

TORNA KALEM MASTARI

KOD	ÖLÇÜ (mm)	FİYAT USD
C321-001	90x40	



DİŐ TARAĐI (METRİK / INCH)

KOD	ADET	FİYAT USD
C329-52	52 PARÇA	



KALIP ALMA ŐABLONU

KOD	ÖLÇÜ (mm)	FİYAT USD
C322-044	130	



RADYÜS MASTARI

KOD	ÖLÇÜ	FİYAT USD
C330.1065	R1-6,5x0,5	
C330.7014	R7-14,5x0,5	
C330.1525	R15-25x0,5	



GRANİT PLEYT DIN 876/1



KOD	BOY (mm)	EN (mm)	YÜKSEKLİK (mm)	AĞIRLIK (kg)	FİYAT USD
C002-4025	400	250	80	30	
C002-6340	630	400	100	80	
C002-8050	800	500	130	150	
C002-1063	1000	630	150	280	
C002-1280	1200	800	160	360	
C002-1610	1600	1000	200	1080	
C002-2010	2000	1000	200	1360	

DÖKÜM PLEYT GB4986-85 GR.1

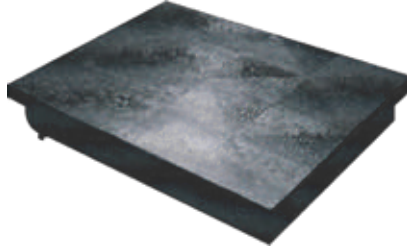

KOD	BOY (mm)	EN (mm)	YÜKSEKLİK (mm)	AĞIRLIK (kg)	FİYAT USD
C002-4030D	400	300	85	15	
C002-6040D	600	400	95	35	
C002-8050D	800	500	100	65	
C002-1075D	1000	750	170	120	

AÇI MASTAR SETİ (10 PARÇA)

KOD	ÖLÇÜ	FİYAT USD
C326-130	1°/2°/3°/4°/5°/10°/15°/20°/25°/30°	



SAATLİ Z SIFIRLAMA APARATI (50 mm)

KOD	ÖLÇÜ (mm)	HASSASİYET (mm)	FİYAT USD
C323-229	50	0,01	



SAATLİ Z SIFIRLAMA APARATI (100 mm)

KOD	ÖLÇÜ (mm)	HASSASİYET (mm)	FİYAT USD
C323-230	100	0,01	



IŞIKLI Z SIFIRLAMA APARATI (50 mm)

KOD	ÖLÇÜ (mm)	HASSASİYET (mm)	FİYAT USD
C323-050	50	0,01	



DİJİTAL Z SIFIRLAMA APARATI (50 mm)

KOD	ÖLÇÜ (mm)	HASSASİYET (mm)	FİYAT USD
C323-228	50	0,001	

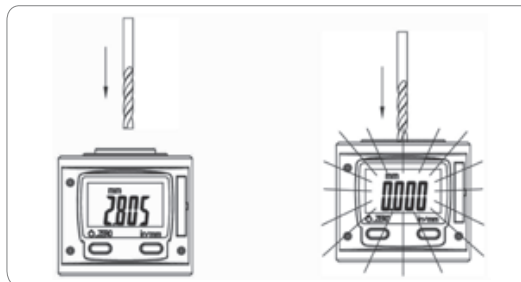

MANYETİK KOMPARATÖR AYAKLARI



C900-0040E



C900-111



C900-MT060A

KOD	UZUNLUK (mm)	GENİŞLİK (mm)	YÜKSEKLİK (mm)	TUTMA KUVVETİ	FİYAT USD
C900-0040E	62	50	55	80 Kg	
C900-111	62	50	55	63 Kg	
C900-MT060A	62	50	55	75 Kg	

İŞIKLI PROP



KOD	ÖLÇÜ (mm)	FİYAT USD
C324-232	20x160	
C324-234	6x120	

İŞIKLI SESLİ PROP

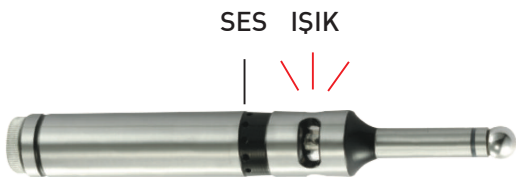

KOD	ÖLÇÜ (mm)	FİYAT USD
C324-233	20x160	

ANTİMANYETİK MEKANİK PROP

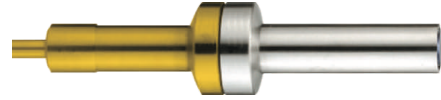

KOD	FİYAT USD
C325-109T	

ANTİMANYETİK MEKANİK PROP ŞAPKALI

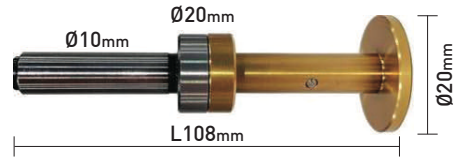

KOD	FİYAT USD
C325-110T	

MEKANİK PROP



KOD	FİYAT USD
C325-109	

10 PARÇA SAATÇİ EĞE TAKIMI

KOD	BOY (mm)	ŞAFT (mm)	FİYAT USD
C271-03140	140	3	
C271-04160	160	3	



3 PARÇA EĞE TAKIMI

KOD	INCH	BOY (mm)	FİYAT USD
C272-3-8	8"	200	
C272-3-10	10"	250	



5 PARÇA EĞE TAKIMI

KOD	INCH	BOY (mm)	FİYAT USD
C272-5-8	8"	200	
C272-5-10	10"	250	



ÇİFT TARAFLI EĞİK ELMAS EĞE TAKIMI

KOD	FİYAT USD
C270-WST2	

TEK TARAFLI EĞİK ELMAS EĞE TAKIMI

KOD	FİYAT USD
C270-WS1	



LAMA ELMAS EĞE

KOD	BOY (mm)	FİYAT USD
C270-14703DZ	140	
C270-16504DZ	160	
C270-20704DZ	200	
C270-215080DZ	215	



ÜÇGEN ELMAS EĞE

KOD	BOY (mm)	FİYAT USD
C270-14703UC	140	
C270-16504UC	160	
C270-20704UC	200	
C270-215080UC	215	



YUVARLAK ELMAS EĞE

KOD	BOY (mm)	FİYAT USD
C270-14703YV	140	
C270-16504YV	160	
C270-20704YV	200	
C270-215080YV	215	



BALIK SIRTİ ELMAS EĞE

KOD	BOY (mm)	FİYAT USD
C270-14703BS	140	
C270-16504BS	160	
C270-20704BS	200	
C270-215080BS	215	



KARE ELMAS EĞE

KOD	BOY (mm)	FİYAT USD
C270-14703KR	140	
C270-16504KR	160	
C270-20704KR	200	
C270-215080KR	215	

ELMAS EĞE TAKIMI



KOD	BOY (mm)	KESİCİ BOY (mm)	ŞAFT (mm)	ADET	FİYAT USD
C270-14703	140	70	3	5	
C270-16504	160	50	4	5	
C270-16504-10	160	50	4	10	
C270-20704	200	70	4	5	
C270-215080	215	80	4	5	

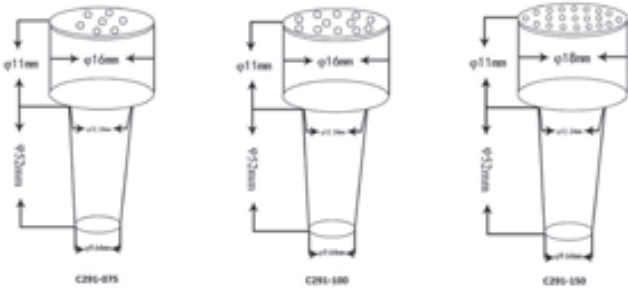

TAŞ DÜZELTME ELMASI

KOD	KARAT	MK	FİYAT USD
C290-030	0,3	1	
C290-050	0,5	1	
C290-075	0,75	1	
C290-100	1,0	1	
C290-150	1,5	1	
C290-200	2,0	1	
C290-250	2,5	1	
C290-300	3,0	1	
C290-400	4,0	1	

ÇOKLU TAŞ DÜZELTME ELMASI

KOD	KARAT	MK	ELMAS	FİYAT USD
C291-075	0,75	1	7	
C291-100	1,0	1	12	
C291-150	1,5	1	24	



SAPLI ELMAS TAŞ

KOD	SET İÇERİĞİ	FİYAT USD
C280-075	3,0 mm 10 ADET / TK	
C280-000	2,35 mm 20 ADET / TK	
C280-100	3,0 mm 20 ADET / TK	
C280-200	3,0 mm 30 ADET / TK	
C280-300	3,0 mm 50 ADET / TK	
C280-400	6,0 mm 10 ADET / TK	



ELMAS ÇİZGİ KALEMİ

KOD	ÖLÇÜ (mm)	FİYAT USD
C008-000U	160 (EKONOMİK)	
C008-000UK	160 (KALİTELİ)	

ELMAS ÇANAK TAŞ KONİK C75

D (mm)	d (mm)	a (mm)	h (mm)	C180-WFW
				FİYAT USD
75	20	5	3	
75	20	10	4	
100	20	5	3	
100	20	10	4	
125	32	5	3	
125	32	10	4	
150	32	5	3	
150	32	10	4	

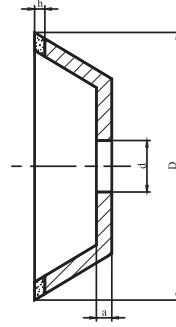

ELMAS ÇANAK TAŞ DİSK C75

D (mm)	d (mm)	a (mm)	h (mm)	C182
				FİYAT USD
75	20	6	3	
100	20	8	4	
125	32	8	4	
150	32	8	4	
175	32	10	4	
200	32	10	4	

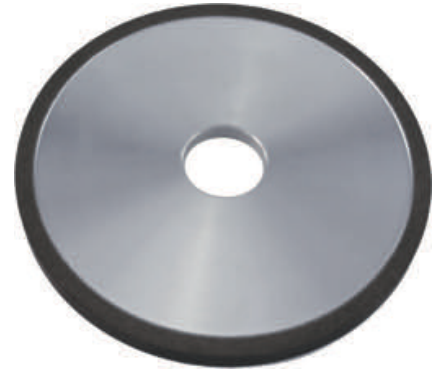
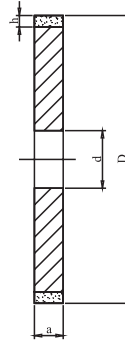

ELMAS ÇANAK TAŞ DİK C75

D (mm)	d (mm)	a (mm)	h (mm)	C180-WCW
				FİYAT USD
75	20	5	3	
75	20	10	4	
100	20	5	3	
100	20	10	4	
125	20	5	3	
125	20	10	4	

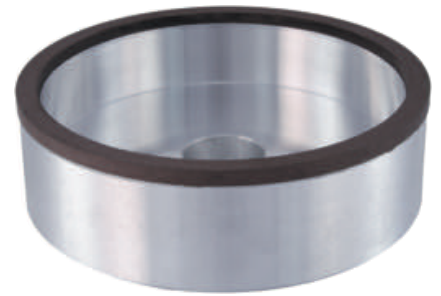
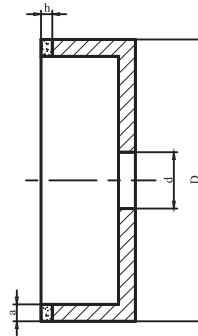

ELMAS BİLEME TAŞI C75

D (mm)	d (mm)	a (mm)	h (mm)	C183
				FİYAT USD
100	32	10	6	
125	32	10	6	
150	32	10	6	

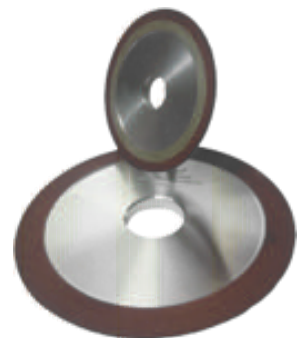
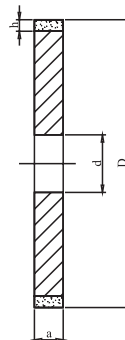

ELMAS MACUNU, 40 GR KUTU

KOD	AÇIKLAMA	FİYAT USD
C190-010-40	W1 MİKRON SARI	
C190-015-40	W1,5 MİKRON PORTAKAL	
C190-050-40	W5 MİKRON AÇIK MAVİ	
C190-100-40	W10 MİKRON AÇIK YEŞİL	
C190-140-40	W14 MİKRON YEŞİL	
C190-200-40	W20 MİKRON MOR	
C190-280-40	W28 MİKRON GRİ	
C190-400-40	W40 MİKRON SİYAH	



ELMAS MACUNU, 5 GR ŞIRINGA

KOD	AÇIKLAMA	FİYAT USD
C190-010	W1 MİKRON SARI	
C190-015	W1,5 MİKRON PORTAKAL	
C190-050	W5 MİKRON AÇIK MAVİ	
C190-100	W10 MİKRON AÇIK YEŞİL	
C190-140	W14 MİKRON YEŞİL	
C190-200	W20 MİKRON MOR	
C190-280	W28 MİKRON GRİ	
C190-400	W40 MİKRON SİYAH	



POLİSAJ SETİ

KOD	AÇIKLAMA	FİYAT USD
C334-105	105 PARÇA POLİSAJ SETİ SAP 3 mm	



ÇAPAK ALMA RASPA YEDEK UÇLARI

B10



KOD	FİYAT USD
C333-174A B10	

B20



KOD	FİYAT USD
C333-174A B20	

E100



KOD	FİYAT USD
C333-174B E100	

E101



KOD	FİYAT USD
C333-174B E101	

E200



KOD	FİYAT USD
C333-174B E200	

E300



KOD	FİYAT USD
C333-174B E300	

E350



KOD	FİYAT USD
C333-174B E350	

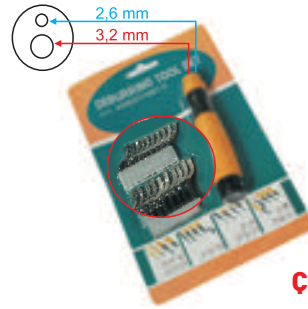

ÇİFT DELİKLİ

ÇAPAK ALMA RASPASI

KOD	AÇIKLAMA	FİYAT USD
C333-174A	ÇAPAK ALMA KISA	
C333-174B	ÇAPAK ALMA UZUN	

ÇAPAK ALMA RASPA SETİ

KOD	AÇIKLAMA	FİYAT USD
C333-174SET	SET (10xB10-10xE200)	



VURMALI TURMETRE

KOD	AÇIKLAMA	FİYAT USD
C008-001	6 HANELİ VURMALI	



TEKERLEKLİ TURMETRE

KOD	FİYAT USD
C008-002	